

The
Comparative Ecology
of Natal's
Smaller Estuaries

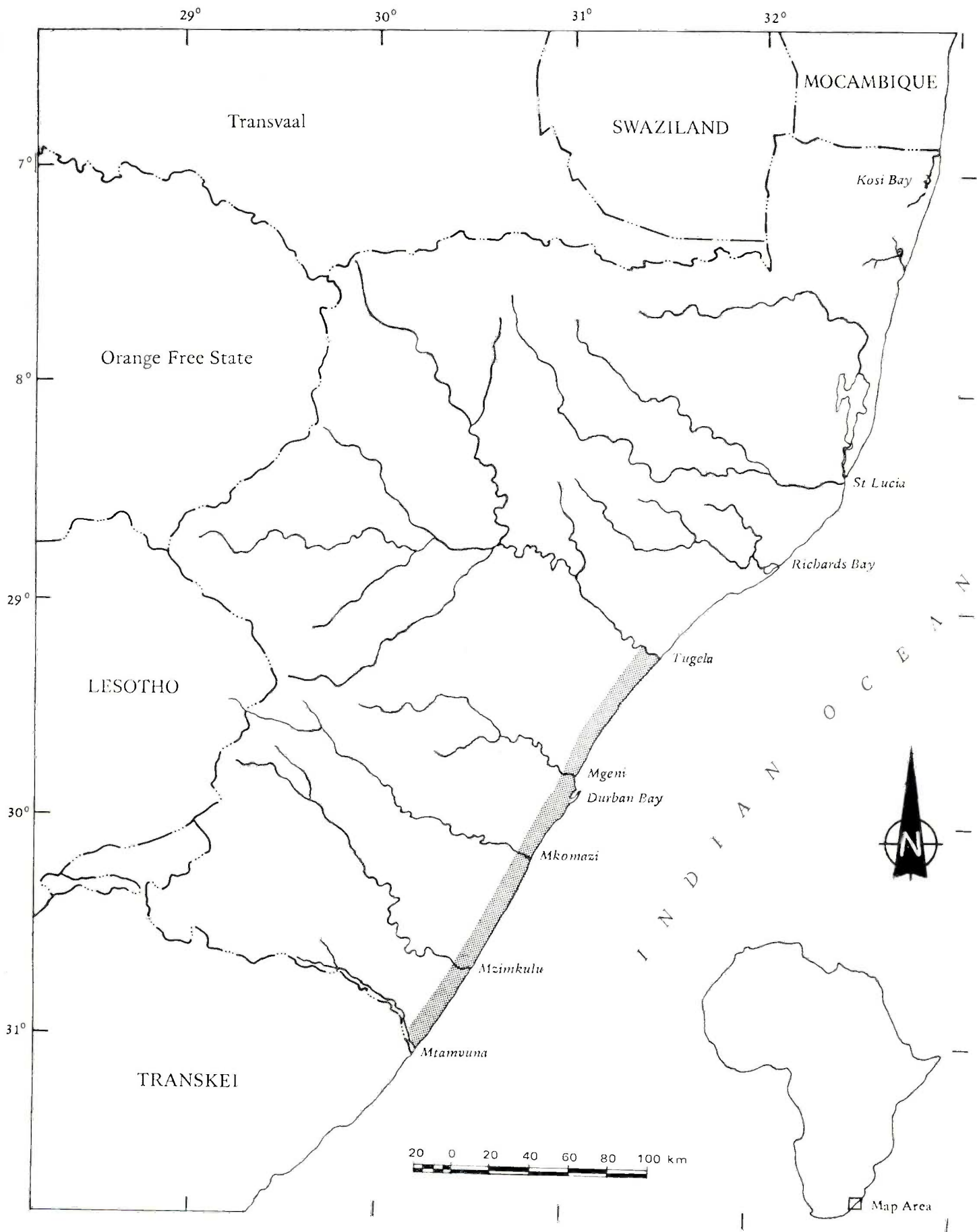

g.w. begg





FRONTISPIECE

Geographical location of the estuaries and lagoons along the Natal Coast. The stippled area demarcates the study area detailed in Fig. 1.

The
Comparative Ecology
of Natal's
Smaller Estuaries

g.w. begg

OCEANOGRAPHIC RESEARCH
INSTITUTE

COVER ILLUSTRATION

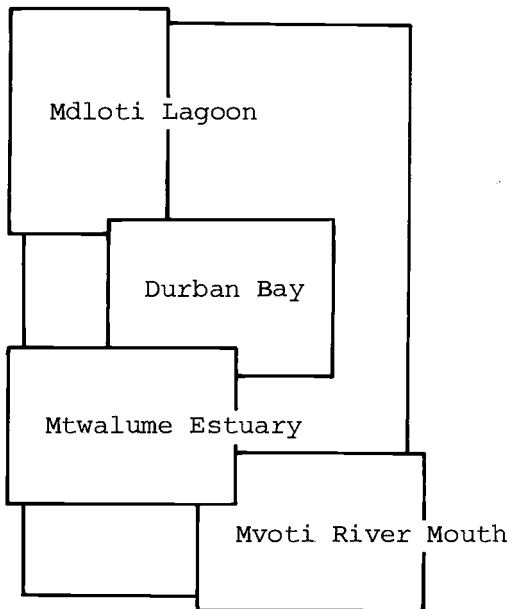

First published in 1984 by

THE NATAL TOWN AND REGIONAL PLANNING COMMISSION
PRIVATE BAG 9038, PIETERMARITZBURG, 3200
NATAL, SOUTH AFRICA

ISBN 0 909232 55. 5

Price R8,50

K & SPMB

CONTENTS

	Page
ABSTRACT	ix
ACKNOWLEDGEMENTS	x
CHAPTER 1 INTRODUCTION	1
CHAPTER 2 METHODOLOGY	
2.1 Study area selection	10
2.2 Field procedure	12
2.3 Laboratory methods	32
2.4 Data analysis	32
CHAPTER 3 AN OVERVIEW OF THE RESULTS CONTAINED IN THE APPENDIX..	34
CHAPTER 4 ESTUARY CLASSIFICATION	
4.1 Introduction.....	59
4.2 Methods	63
4.3 Results	68
4.4 Discussion	114
CHAPTER 5 ESTUARY CHARACTERIZATION	
5.1 Introduction	119
5.2 Temporal characterization	121
5.3 Spatial characterization	136
5.4 Discussion	141
CHAPTER 6 APPLICATIONS and CONCLUSIONS	147
REFERENCES	166
PERSONAL COMMUNICATIONS	182

LIST OF FIGURES

	page
Frontispiece - Geographical location of the estuaries and lagoons along the Natal coast.	
1. The study area	11
2. Details of the beam trawl used for sampling	18
3. Details of the water sampler used throughout the study period	23
4. Details of the coring device manufactured to obtain a sample of the substratum at each sampling site	25
5. The relative proportions of sand and silt fractions in the more commonly encountered types of substrata in estuaries and lagoons.	28
6. Schematic representation of the twelve principal hydrological events affecting the environmental character of the systems studied.....	29
7. The relative species richness of 60 systems south of the Tugela River in Natal. To equate the relative effort expended trawl netting in each system, the total number of fish, prawn and crab species caught after <u>three</u> visits to each system are shown.....	57
8. The conceptual basis of a classification strategy for Natal's estuaries (adapted from Gosselink & Turner, 1978 and Breen, 1982)	61
9. Spatial relationships between two samples and three species in species space and samples space	66
10. The ordination of 59 systems in Natal by detrended correspondence analysis, using the presence or absence data contained in Table 16	74
11. A three dimensional plot of the presence/absence data contained in Table 16.....	75
12. The ordination of the fish species listed in Table 16 by detrended correspondence analysis	77
13. The ordination of the prawn and crab species listed in Table 16 by detrended correspondence analysis	79
14. The sample groups defined by ordination space partitioning after ordination of the data in Table 16 by detrended correspondence analysis.....	81

15.	The ordination of 59 estuaries in Natal by detrended correspondence analysis, using the CPUE data in Table 12....	83
16.	The relationship of the seven sample groups and five outlying samples in Figure 14 to mouth condition	87
17.	The relationship of the seven sample groups and five outlying samples in Figure 14 to catchment size	87
18.	The relationship of the seven sample groups and five outlying samples in Figure 14 to system size	90
19.	The relationship of the seven sample groups and five outlying samples in Figure 14 to salinity	90
19a	Interactive diagram of the factors influencing salinity as a component of an estuarine ecosystem	91
20.	Relationships between the 62 systems studied according to size, mouth condition and mean bottom salinity	93
21.	The relationship of the seven sample groups and five outlying samples in Figure 14 to water transparency	95
21a	Interactive diagram of the factors influencing water transparency as a component of an estuarine ecosystem	96
22.	The relationship of the seven sample groups and five outlying samples in Figure 14 to salinity stratification ...	95
22a	Interactive diagram of the factors influencing salinity stratification in an estuarine ecosystem	97
23.	The comparative proportions of four common lagoon-associated species (<u>Gilchristella aestuarius</u> , <u>Glossogobius giurus</u> , <u>Oreochromis mossambicus</u> and <u>Rhyncoplax bovis</u>) expressed as a percentage of the total catch (Table 14) in relation to the sample arrangement in Figure 15	102
24.	Temporal variation in community structure of the Mkomazi Estuary after ordination of the data in Table 19	122
25.	Flow of the Mkomazi River (from records maintained by SAICCOR, see Appendix) on those occasions the estuary was being sampled	122
26.	Temporal variation in community structure of the Mgeni Estuary after ordination of the data in Table 20 (Appendix)	125
27.	Temporal variation in community structure of the Zinkwasi Lagoon after ordination of the data in Table 2 (Appendix)	128

28.	Temporal variation in community structure of the Mdloti Lagoon after ordination of the data in Table 16 (Appendix)	128
29.	Temporal variation in community structure of the Msimbazi Lagoon after ordination of the data in Table 37 (Appendix)	131
30.	Temporal variation in community structure of the Manzimtoti Lagoon after ordination of the data in Table 31 (Appendix)	133
31.	Temporal variation in community structure of the Manzimtoti Lagoon after ordination of the data in Table 21	133
32.	Differences in community structure above the weir and below the weir in the Mdesingane Lagoon	138
33.	Differences in community structure above the freeway and below the freeway in the uMgababa Lagoon	138
34.	Differences in community structure within the Impisini Inlet, a backwater of the Mkomazi Estuary, and the Mkomazi itself	143

LIST OF TABLES

	page
1. Environmental criteria used for the selection of 14 systems to form the basis of a classification scheme	13
2. Variation in the environmental character of the 14 systems selected for study in the first two years.....	14
3. Variation in the number of samples per trip per system and overall	16
4. Variation in species composition between six consecutive four-minute trawls over the same pitch in the Manzimtoti Lagoon	20
5. Data from the Mdloti Lagoon, illustrating the influence of water depth on catchability	21
6. Variation in species composition by night and by day for the same duration of haul over the same trawl track in the Mdloti Lagoon	22
7. A system devised for classification of the substratum in the area of the trawl track. This was achieved by visual and tactile means whilst crushing a sample of the substratum underwater. The results of particle size analysis for the more commonly encountered substratum types are included	26
8. Simplified method of classifying by sight the nature of the influential vegetation in the area of the trawl track...	27
9. Variability of environmental data at the start and finish of 54 trawl tracks. Values underlined are significantly different at a 95% level of confidence.....	30
10. The variation in characteristics of an abiotic nature in each of the 62 systems studied. The data presented are concentrated around those biophysical facets of estuarine systems thought to be significant to the purpose of classification	36
11. The variation in mouth condition, water level, salinity and water transparency at the deepest point of a typical range of estuaries and lagoons along 44 km of the Natal coastline in September 1982.....	39
12. Relative abundance (in catch per minute) of 125 trawl susceptible species from 62 estuaries and lagoons south of the Tugela River	42
13. Relative abundance of 90 of the species caught by trawl netting in 62 different estuarine localities in Natal during the period September 1979 to November 1982.....	53

14.	The comparative proportions of four commonly encountered species (expressed as a percentage of the total catch) in closed systems as opposed to open systems.....	55
15.	A provisional basis for the classification of "estuaries" in Natal using the criteria contained in the definition of an estuary provided by Cameron and Pritchard (1963), plus tidal exchange	64
16.	The occurrence of the 125 species caught during the study period in relation to their distribution within the study area	70
17.	A list of the environmental variables selected from the Appendix (unless otherwise indicated) to examine the distribution of each variable between the sample groups in Figure 14	84
18.	A revised basis for the classification of "estuaries" in Natal	113
19.	The frequency of occurrence and relative importance of the species caught in 132 trawl samples from the Mkomazi Estuary over a 22 month study period	123
20.	The variation in water level in the Mdloti Lagoon on those occasions the system was sampled during the period September 1979 to July 1981	130
21.	The relative abundance of the species caught in 86 trawl samples from the Manzimtoti Lagoon expressed as a percentage of the total catch on each trip	135
22.	The frequency of occurrence and distribution of species caught in 12 trawl samples from the Mdesingane Lagoon over the period February to August 1982	137
23.	The frequency of occurrence and distribution of the species caught in 58 trawl samples from the uMgababa Lagoon	140
24.	A 22 month comparison between community structure in the Impisini Inlet (a backwater of the Mkomazi) and the main body of the Mkomazi Estuary	141

A B S T R A C T

Fifty one of Natal's 73 estuaries have been almost completely overlooked in terms of any scientific study, despite which a marine nursery function has commonly been attributed to each of them. In the knowledge that many of these systems were normally closed and others were in a seriously degraded state, this study was undertaken with the aims of examining their present day community structure in order to provide a basis upon which their future condition can be monitored and to provide a classification of these coastal resources.

The study area incorporated 62 different systems extending over 240 km of the Natal coastline south of the Tugela River. During the three year study period (Sep 1979 - Nov 1982) 82 515 specimens, comprising an assemblage of 125 different species, were caught by means of a small beam trawl. These comprised 86 species of fish, 21 species of crabs and 18 species of prawns. The data obtained were correlated with abiotic variables such as mouth condition, salinity, temperature, dissolved oxygen, water transparency, depth, nature of the substratum and peripheral vegetation.

Based on the ability of biota to synthesize environmental variables into one common response, multi-variate analysis is used to demonstrate the similarity in community structure between open and closed systems (for example) or between fresh and saline systems, and thereby resolve an age-old argument about estuary classification. The data also suggest that in their present day condition only six of the systems studied make a significant contribution to the recruitment of estuarine-dependent marine stocks (sensu stricto) principally because of their open mouth condition. Closed systems, deliberately classified as lagoons, have a different resource value, being utilized primarily by resident species that can complete their life cycle within the system. An appreciation of this salient difference helps to reinforce the critical need for an effective management strategy to be implemented to prevent Natal's dwindling estuarine resources from deteriorating any further.

The term 'estuarine-dependence' is critically examined in this context to show that a species more dependent on estuaries than any other, is man. It is argued that man's continued abuse of these resources is shortsighted, and that the most serious threat of all is sedimentation, accelerated in this instance beyond the geological norm by catchment mismanagement.

The practical application and value of classification to planning and management is demonstrated and a methodology proposed, based on community responses, for the monitoring of the future environmental condition of each estuary and lagoon in Natal.

ACKNOWLEDGEMENTS

Try as one might to shoulder the task, an undertaking such as this relies to a very large extent on the help and cooperation of numerous people and institutions. Consequently it gives me the greatest of pleasure to express my appreciation of their much valued assistance.

Above all else the study requires financial support and sponsorship, and for this reason the Natal Town and Regional Planning Commission deserves and has my unparalleled gratitude. For the same reason I am grateful to the Oceanographic Research Institute (ORI) for the congenial and stimulating atmosphere in which to have worked for the past seven years.

In their personal capacity, I am indebted to Prof. A.P. Bowmaker (Director, ORI), Prof. J. Hanks (Director, Institute of Natural Resources) and Dr A.J. de Freitas (Principal Research Officer, ORI) for their supervision of the study. I found their constructive advice and guidance to be of inestimable help, and appreciated the hours each of them spent either patiently reading the drafts of this manuscript or uncomfortably confined to the bows of the "HMS Aestus".

I am indebted to Tony de Freitas for many reasons, but above all else I consider his unfailing readiness as a source of knowledge, encouragement and argument to have been an essential ingredient in this study. His advice on the identification of prawns and on the construction of gear, and his help with the computer and in the field will always be sincerely appreciated.

It is also a pleasure to associate Rudy van der Elst (Senior Research Officer, ORI) with this project, but in particular for his role in the writing of computer programmes. The latter were essential to the execution of this research and will be to the continuity of such research in the future. A fortuitous attribute of Rudy's assistance as programmer was his own thorough understanding of estuaries and estuarine biota. He made available the water sampling bottle used throughout the study, and taught me a great deal about the identification of fish.

I am also indebted to Peter Goodman of the Natal Parks Board who introduced me to the world of multi-variate analysis and for invaluable assistance in the analysis and interpretation of my data. I profited from every minute of my discussions with him and learnt to respect his insight into the concepts and problems that are basic to all ecosystem research. I also gratefully acknowledge the skills of Derek Chalton (Dept of Biometry and Statistics, University of Natal) and Tim and Anna Crowe (Fitzpatrick Institute of African Ornithology, University of Cape Town) for computer assistance. The frustrations encountered with mispunched data were entirely of my own making.

For construction and maintenance of field gear I would like to thank Ginger Hellyer and his associates, namely Roy Jackson (for his construction of the net frame and coring device), Vernon Hellyer (for the screen) and Dave Taylor (for continual maintenance of my vehicle and outboard motor).

Fieldwork is generally the most pleasurable part of any biological study, and for this reason field assistance is relatively easy to acquire. However, few are aware of the mud-splattering rigours that await the uninitiated in estuarine studies, and I am particularly grateful therefore to Henry Davies who, in 1980, gave up a good proportion of his hard-earned sabbatical leave to assist me in the field. His promotion to 'second mate' during this period speaks for his unflagging interest and considerable help. I also appreciated the team effort made by Tony de Freitas, John Ballard, Roy Jackson, Frank Junor and Chris Cundall, who on two occasions helped test the efficiency of the trawl against a variety of other sampling techniques.

Several people assisted me in the laboratory in the processing of specimens and the checking of data. These include Henry Davies, Ailsa Lawson, Bianca van Hoogdalem and my wife, Lea. In the reading out of so many figures, it is the first time I have ever known her to be rendered speechless! One of the most essential people in any research project at the ORI is the librarian, and I would like to compliment Judith Thompson on her efficiency. She was of considerable help to me in locating and compiling the references consulted.

I am indebted to the staff of the NTRPC's Drawing Office for reproduction of the drawings in the Appendix and wish to thank in particular Basil Armitage, Heather Young and Diana Matheson for their dependability and cooperation over the years.

For her fortitude in the exacting task of typing this manuscript (twice over) I am forever grateful to Lorna Cameron. I admire her patience and consistently accurate work, and the determination she displayed in mastering the operation of ORI's newly acquired word processor.

I also give special recognition to the following for their help in the identification of both animals and plants encountered during the course of the study:

Prof. M.M. Smith for the identification of fish

Dr A. Jacot Guillarmod for the identification of aquatic plants;

Prof. J. Day for the identification of crabs and

Dr R. Kilburn for the identification of molluscs.

Thanks are due to the NIWR (in particular Ashley Butler) for the supply of Winkler reagents used for oxygen determinations throughout the study, and to Prof. J.M. de Villiers (Dept of Soil Science and Agrometeorology, University of Natal) for undertaking the substratum particle size analyses. I am also grateful to Mr. Dennis Griffiths from the Regional Office of the DWA who, for the last three years has religiously provided me with the analyses of periodic water samples taken from all the estuaries and lagoons on the south coast of Natal.

I have been privileged to make use of the daily records of estuary mouth condition that Ted Beesley, Fred du Preez and Bob Hammerich (all of SAICCOR) maintain between Scottburgh and Amanzimtoti; and to the North Coast Regional Water Services Corporation (Mr Malpas) for providing such data from the Mloti. The Zinkwasi Beach Health Committee provided these data for the Zinkwasi; the Natal Parks Board for the Mhlanga; and the Boroughs of Uvongo, Margate and Ramsgate for all the systems between St Michaels-on-Sea and Ramsgate. Further south, several private individuals volunteered to do the same thing. These include Mr J. Cochrane (for the Mbizana); Mrs P. Wilson-Jones

(for the Kaba); Mr R. Foster and Mr H. van Wijk (for the Umhlangankulu) and Mr M. Christie (for the Kandandlovu). I am indebted to them all for providing what has proved to be one of the most pertinent facets of information anyone studying the lagoons of Natal could possibly wish to have.

Finally, I am grateful to the following local authorities and private individuals for granting me access to the systems in their domain or adjacent to their properties:

The people of KwaZulu	C.G. Smith Ltd
Development and Services Board	Estate Manager, "San Lameer"
The Natal Parks Board	Transvaal Teachers Assoc.
Port Captain, Durban Harbour	Proprietor, "Villa Siesta
Durban Corporation	Natal Estates
Borough of Amanzimtoti	Mr A. Eggars
Borough of Kingsburgh	Mr R. Bodasing
Borough of Isipingo	Mr F. Jex
Borough of Scottburgh	Mr L. Jackson
Borough of Port Shepstone	Mr K. Hargovan
Borough of Uvongo	Mr C. Pretorius
Borough of Margate	Mr G. Farmer
Zinkwasi Beach Health Committee	Mr I. Kinnear
Ramsgate Town Board	Mr P. Viljoen
Bendigo Town Board	Mr G. Coser
Tongaat Town Board	Mr D. Whateley
Southbroom Health Committee	Mr B. Hodson
Munster Health Committee	Mr M. van Duyn
Pennington Health Committee	Mr A. Williams
Crookes Bros (Pty) Ltd	

LIST OF ACRONYMS

- CPUE - Catch per unit effort
- CSIR - Council for Industrial and Scientific Research
- DWA - Directorate of Water Affairs
- EAC - Estuary Action Committee
- LSCRWSC - Lower South Coast Regional Water Services Corporation
- NPB - Natal Parks Board
- NTRPC - Natal Town and Regional Planning Commission
- NIWR - National Institute of Water Research
- NRIO - National Research Institute for Oceanology
- ORI - Oceanographic Research Institute
- SAICCOR - South African Industrial Cellulose Corporation

CHAPTER ONE

INTRODUCTION

Generally speaking most people consider an estuary as a place where rivers meet the sea forming a transition zone between freshwater and seawater due to the influence of the tides (Pritchard,1967). Others designate estuaries as brackish water areas (Caspers,1967) but it is clear from the many attempts to define what is meant by an estuary that, because the term may be applied in so many different ways, no one definition has yet proved to be entirely suitable. Despite this, over the last two decades the biological significance of estuaries has received more and more attention because above all else some estuaries have been found to be extraordinarily productive. Research showed that estuaries can have a net primary productivity of about 2000 g of plant matter per square metre per year compared with means of $730 \text{ g m}^{-2} \text{ yr}^{-1}$ for total land productivity and $155 \text{ g m}^{-2} \text{ yr}^{-1}$ for total ocean productivity (Knox,1980).

Although this concept is no longer popular (Nixon,1980) the maximization of estuarine productivity irrespective of its magnitude should be regarded as critical for mankind faced as he is by the threat of exponential population growth and an ever increasing demand for food. Thus the International Union for Conservation of Nature and Natural Resources (IUCN) regards coastal and freshwater systems one of the three most important and threatened "life-support systems" in the world and has launched a global appeal through the publication of the World Conservation Strategy (IUCN,1980) for their conservation. The IUCN's interpretation of conservation is "the management of human use of the biosphere so that it may yield the greatest sustainable benefit to present generations". Implicit in this concept is an appreciation of the carrying capacity of ecosystems and the realities of resource limitation.

Throughout the world, people are concerned about the degradation of estuaries (McHugh,1968; Odum,1970; Hedgpeth,1975; Pollard,1976, 1981) and many others cited in the following discussion. At the Fourth International Conference of the Estuarine Research Foundation, for example, the President, Dr F.J. Vernberg, opened the proceedings by

saying that "...estuaries and adjacent environments are ecological systems that are subjected to continual stress by natural and man-induced perturbations" (Wiley,1978; Kennedy,1980). Varying circulation patterns, salinity, the deposition and erosion of sediments and the coming and going of animal life all result in an instability of the system which in itself becomes the most distinctive biological feature of the estuarine environment in general. Further changes become induced by the multiplicity of uses that man demands of estuaries. Ketchum (1969) draws attention to the problem by quoting the following letter which originated from the Conservation Foundation Washington D.C. in 1967. It reads as follows:

"What is an estuary? To the scientist an estuary is very fertile and more productive of plant and animal life than either land or the sea. To some an estuary is an unused space to be developed for housing projects, industrial sites, roads, marinas, golf courses, amusement parks and sewage treatment plants. To commercial and sport fishermen estuaries are vital. Over 90% of the total harvest of seafood taken by American fishermen comes from the continental shelf and about two-thirds of that volume are species that are in some way estuarine dependent. To the harbour developer seeking to dredge and fill an estuary it was not 'a veritable paradise' because although it did support wildlife, it also supported vermin such as rats and mosquitoes. To another developer seeking to build upon an estuary, only concern about the 'love-life of fiddler crabs' stood in his way. To the sand and gravel industry, estuaries are a principal source of these raw materials for construction. To some others estuaries are to be left untouched for enjoyment and relaxation, for recreation without development, and for a closeness to nature".

This suggests that throughout the world estuaries have always been a favourite site for human settlement (Cronin,1967) and consequently have been subjected to a wide variety of uses (Lankford,1976). In addition they also receive the impact of human activities throughout the entire catchment of the rivers that drain into them and act as a natural pollutant trap. Their vulnerability lies in the sensitivity of the life that thrives within them (Knox, 1980).

In the South African context the functioning of estuaries (Wallace,1975c; Blaber,1980) and the factors that threaten that environment (Heydorn,1972; Grindley,1972, 1974) are regarded as identical to those outlined above. Huntley (1978) maintains for example, that estuaries are more seriously threatened than any other ecosystem in Southern Africa. For these reasons numerous organizations have over the years made a concerted effort to acquire a thorough understanding of South African estuaries as a fundamental requirement for the conservation and management of this resource. With specific reference to Natal for example there are approximately 32 reports on estuaries (published and unpublished) available from the Oceanographic Research Institute (ORI). The most important of these are three Investigational Reports by Wallace (1975a,b & c). Over and above this the National Institute of Water Research (NIWR) has been responsible for writing approximately 45 reports on estuarine matters (mainly unpublished), the most pertinent being a confidential series conducted in the 1970's on environmental pollution (Hemens et al., 1971,1972,1973; Oliff et al.,1977 a,b & c; Connell et al., 1977). Similarly staff and students at the University of Natal have, apart from numerous theses, produced well over 40 published papers on estuarine topics significant amongst which have been those contributed by Blaber (1976,1978), Whitfield (1976,1979) and Forbes (1979). In recent years the Natal Town and Regional Planning Commission produced an inventory of the state of knowledge on estuaries (Begg,1978) and a policy document for the formulation of an overall management strategy (Begg,1979). A review of South African estuaries has just been completed by Day (1981) and the government is currently supporting a study by the National Research Institute for Oceanology (NRIO) of 167 estuaries in the Cape Province (Heydorn & Tinley,1980).

One of the most thought provoking disclosures made during the process of reviewing the present day state of knowledge of Natal's estuaries (Begg,1978) was the fact, that 51 out of Natal's 73 estuaries had virtually never been studied at all. Most of the work on Natal's estuaries had been conducted on large open systems (Frontispiece) such as St Lucia (Day,1954; Millard & Broekhuysen,1970; Wallace,1975 a & b; van der Elst et al.,1976; Blaber,1976), Richards Bay (Millard & Harrison, 1954; Hemens et al.,1970) and Kosi (Campbell & Allanson,1952; Broekhuysen & Taylor,1959; Heydorn & Wallace,1973;

Blaber, 1978) .

In essence Natal's smaller estuaries had either been neglected by the scientist or at best surveyed by Prof. J.H. Day (unpublished data) on single occasions as long ago as 1950. Consequently the tendency to attribute conventional estuarine functions to each and every estuary in Natal began to be questioned by decision makers such as planning authorities and governmental agencies (Pistorius, pers.comm.).

One of the main reasons for this attitude arose from the fact that Begg (1978) classified 56 of Natal's estuaries as 'lagoons' because they were seasonally or normally closed to the sea, a condition which according to Scott et al. (1952), Grindley (1980) and Hodgkin (1980) reduced their value as nursery areas.

Another factor that cast some doubt on the validity of continuing to attribute nursery functions to every estuarine system in Natal was their present day environmental condition. Although the assessment made was subjective, the schedule compiled (Begg, 1978, p.19) gave some indication as to which of Natal's estuaries still appeared to have a nursery function, which appeared to be losing this function and which appeared to have lost it. This assessment was based on criteria such as the degree to which peripheral plant communities had become disturbed, the diversity of the animal life present, the mouth condition, the depth, and the quality of the water. The net result was that only 20 of the 73 'estuaries' in Natal were considered to be functional.

It seemed clear at the time that a gradation existed from a functional estuary at one end of the scale to a system that was no longer an estuary at the other. Furthermore, it was obvious that man had played a significant part in bringing about this variation.

Thus, with these hypotheses in mind it seemed imperative that an in-depth study of these small, possibly misunderstood, systems be conducted. An added incentive of doing so was the knowledge that it was the small estuaries of Natal which were the most vulnerable to the developmental pressures at which conservationists constantly level criticism (Begg, 1980).

From the beginning it was clear that for the proper fulfilment of the task a great deal of fieldwork had to be undertaken. The problem was compounded by the fact that with the finances available it would have to be undertaken single-handedly. Consequently the solution lay

in the adoption of a sampling strategy that was simple to operate but effective. An example of this strategy can be seen in the assessment of the nature of the substratum, because sophisticated techniques of data collection and analysis were not used. The results were checked nevertheless and found compatible with more complex methods. The boat and motor used for this study were also carefully chosen so as to be robust while at the same time sufficiently light to enable them to be carried to the water's edge, often over difficult terrain.

Even the philosophy underlying the study, namely the use of biological indicators, was simple and well tested. It is well known for example that both single species (Bedford et al.,1968) and communities (Cairns,1974; Jones et al.,1981) can be used as an accepted measure of the health of an ecosystem. They reflect external environmental stresses as well as internal stability and productivity. The Thames Estuary, which was totally lifeless 15 years ago, serves as a good example.

In the Thames there has been a steady biological response to the modernisation of sewage works and control of industrial wastes. Ninety six species of fish have since returned to the estuary and thousands of various waders and ducks now occur on the water's edge where previously a perpetual film of detergent denied such utilization because of the effect of detergents had on the waterproofing quality of their feathers (Green,1979). The lesson to be learnt is that monitoring of those communities revealed a great deal about the quality of the environment without the use of anything more sophisticated than a trawl and a pair of fieldglasses! In their research on the rivers of Natal the NIWR successfully used the freshwater fauna as a means of determining the degree of organic enrichment according to its effect on the population density and tolerance of certain animals to pollution (Brand et al.,1967). Amongst other things this work showed how species diversity increased in unpolluted waters. Bechtel and Copeland (1970) also showed that fish diversity was negatively correlated with pollution levels.

The benefits to be derived from grading estuarine resources according to their biological nature has been foreseen for several years (Haedrich & Haedrich,1974; Siegfried,1981 a & b), but the problem has always been one of the unavailability of the relevant data. The results of such a research approach was seen to be of

considerable value to management as it would be a possible means of identifying those features of an estuary that were most sensitive to interference and stress, as well as in determining that point on the envisaged scale of variation between them, where flexure occurred thereby demarcating a condition at which an estuary ceases to function in its classical manner.

It was decided that three years of fieldwork would be required to complete the study. During the first year eight carefully chosen, widely differing systems were selected and sampling techniques were refined. In the second year an additional six systems were added to increase the spectrum of estuary types being studied, and an array of computer programs for analysis of these data were developed and tested. On the basis of this background, 48 systems were sampled at less frequent intervals in the third year of study. In practice only 46 were sampled satisfactorily because two systems (the Vungu in excess of 30 m deep, and the Zolwane floored entirely by rocks) proved to be unworkable.

Much time was spent in choosing the sampling gear suitable for the task at hand. Every system considered as stressed by Green (1979) had its inherent limitations. The final choice of a beam trawl was made because it was operable by a single person and because preliminary sampling to evaluate the method proved adequate for the purposes of this study. The net was found to capture a surprisingly wide spectrum of animals ranging from nektonic to benthic forms, and included even those that tend to bury themselves in the substratum. It was recognised that a beam trawl was essentially a technique for sampling demersal species and consequently surface dwelling organisms would be undersampled. This bias in trawl susceptibility was not regarded as a serious disadvantage because it would be consistent throughout the survey and because estuaries are "a system in which control by the bottom materials is the dominant influence" (Hedgpeth, 1967).

The feasibility of sampling at night as well as during the day was given due consideration (Table 6) because of likely diurnal variations in species presence and abundance. However to undertake night sampling, assistance was essential and it was decided not to become over-concerned about this aspect because one of the objectives of the study was to develop a technique which could be used as a routine for characterizing estuaries (Chap.5). If the requirement of night

sampling was made essential the wider application of the technique would be considerably reduced.

Considering the dynamic nature of an estuary, and in anticipation of gathering a large amount of abiotic and biotic data from each of the study areas, the need to develop a computerized data bank became essential. This approach became reinforced after reviewing the subject of Natal's estuaries in 1978, as this experience highlighted the limitations of collecting data in an inconsistent manner, largely because of differences in the sampling techniques employed by each researcher. This made the meaningful comparison of data extremely difficult and emphasized the necessity to gather comparable data comprising a computerized suite of standard variables from each estuary. For the same reason, multivariate methods of analysis became imperative. Multivariate analysis enables easy summarization of the data, effective communication of the results and insight into the structure of community data (Gauch, 1982). Today there are several such techniques available such as cluster analysis, ordination and gradient analysis. Cluster analysis allows the researcher to reveal patterns of hierarchical similarity among heterogeneous data sets, whereas ordination is a technique which provides a most useful insight into the underlying structure of the data and of inter-relationships between samples. The major directions of variation correspond to identifiable environmental gradients and a technique which greatly facilitates the detection of such trends is gradient analysis. The use of techniques such as these was seen as an objective means by which the null hypothesis (i.e. that all estuaries in Natal perform the same ecological function) could be tested as well as be a means of distinguishing, for example, environmentally stressed estuaries from unstressed estuaries; or estuaries from 'lagoons'; or identifying those factors that adversely affect the functioning of estuarine environments in general.

The study is considered to be distinctly user-orientated because the classification envisaged should provide management with a rational basis for distinguishing between specified types of estuaries for planning purposes. It would also facilitate decisions regarding permissible uses of estuary surrounds depending on their type. It would illustrate which of the estuaries should possibly be set aside for conservation and help to clarify what research needs to be

directed at obtaining a better understanding of each estuary type. Over and above these benefits, another important advantage to be derived from the analysis of community data was the possibility of predicting the reaction of estuaries to perturbation, and determining at any future date changes in the character of an estuary subsequent to this baseline study. Such changes in character could be used for example as a warning system of damage by pollution or some other environmental change.

To summarize, the objectives of the present study therefore were

- o to determine by means of a beam trawl the degree to which Natal's smaller estuaries and lagoons are being utilized by marine species;
- o to provide a basis upon which the future condition of estuarine systems in Natal can be measured, and
- o to provide a classification of these systems based primarily on their biological attributes.

The information set out in this Chapter provides the background for the present study and the reasons why the approach taken was adopted. In Chapter 2 the methods used for the study are presented in greater detail. A synthesis of the results is contained in Chapter 3 because the details of each of the 62 estuaries studied are presented as an Appendix to this thesis, specifically written to serve simultaneously as a supplement to NTRP Report Vol.41 (Begg,1978). In Chapter 4 the data in the Appendix are used to produce a classification of the systems studied, and this is verified in an objective manner using multivariate data analysis. The reason for differentiating between estuaries and 'lagoons' is also stressed, and the environmental factors that account for the relationships evident in Chapter 4 are examined. In Chapter 5 an attempt is made to characterize selected systems by determining what variation in community structure occurred during the study period, as well as to characterize different sites within them because of spatial differences in community structure. The prospects of building a similar data base for every

system in Natal are also considered. In Chapter 6 the study is drawn to its logical conclusion by re-examining the present day manner in which Natal's smaller estuaries and lagoons are utilized by marine, estuarine and freshwater organisms. This is achieved by assessing topics such as species richness, the relative number of resident versus non-resident species present in each system and indicator species. Emphasis is given to the value of estuarine classification to management and to sedimentation as the most serious single threat to the future welfare of these ecosystems. Attention is also drawn to MAN as an estuarine dependent species, and common misconceptions of the ecology of lagoons.

CHAPTER TWO

METHODOLOGY

2.1 Study area selection

The Province of Natal is situated on the east coast of South Africa and its coastline extends 570 km between the border of Mozambique, in the north, and the border of the Transkei in the south (Frontispiece). Although the coastline is relatively straight, it is interrupted by 73 estuaries of varying sizes (Begg, 1978) which contrast markedly with those in Mozambique (Day, 1974; de Freitas, 1980) and those in the Transkei (Blaber *et al.*, 1974; Wooldridge, 1976; Branch and Grindley, 1979) largely because of different geomorphological influences, a different climatic regime and the different character of the contributing watersheds.

The Tugela River forms a natural divide between southern and northern Natal. On the coast the area north of the Tugela is dominated by the Zululand coastal plain (Maud, 1961; King, 1972; Orme, 1974), a tropical climate and a tropical fauna and flora (Bruton, 1980), strongly influenced by the warm southward flowing Agulhas Current. Within this area are the largest and the best studied of Natal's estuaries (Begg, 1978).

South of the Tugela the topography becomes steeper, with a consequent increase in the number of rivers draining smaller catchments in which precipitation, streamflow and land use patterns are different. Within this area are 62 small, poorly studied estuaries, selected to form the focus of this study (Fig.1). On average their frequency of occurrence is one estuary per 3,9 km of coast. In total (excluding Durban Bay) they occupy 650 ha, i.e. only 1,6% of the total extent of what could be considered as estuarine waters in Natal.

During the first two years of study 14 systems were chosen to form the basic framework of a classification scheme in which any system studied thereafter could be incorporated. The criteria used to make this selection were based on geographical, logistical and environmental considerations.

The systems were divided equally so that seven of them lay to the north of Durban (Zinkwasi, Mhlali, Tongati, Mdloti, Mhlanga, Mgeni and

Durban Bay) and seven lay to the south of Durban (Manzimtoti, Little Manzimtoti, Lovu, Msimbazi, uMgababa, Mkomazi and Mahlongwa). All of them were chosen to lie within 100 km of the city, to reduce the costs and time spent in travel. Moreover, they varied in environmental condition from good, to fair, to poor (Table 1) and exhibited considerable variation in terms of size, mouth condition, salinity, vegetation and the extent to which man-induced or natural perturbation was evident (Table 2).

In the third year of study the remaining 48 systems, lying further afield, were studied. Travel time was reduced by staying in the field for periods ranging from 3-10 days.

2.2 Field procedure

2.2.1 Selection of sampling sites

The value of backwaters and marginal areas for the support of juvenile organisms in an estuary has been demonstrated by de Freitas (1980) and Blaber (1980). Accordingly, a deliberate effort was made to obtain samples from such localities, to try to sample the same site at each visit and to spread the sampling effort from the lower to the uppermost reaches of the system. In practice, fluctuation in water level created difficulties and forced the exact location of trawls to become variable so, under the circumstances, fixed sampling stations could not be used. However, it should be noted that in relation to water level the same general area was sampled on every occasion.

In open estuaries, tidal influences and the nature of the mouth dominate the level to which water rises or falls within the system, whereas in closed systems the water level gradually rises and falls over a period of weeks or months behind a sandbar that separates the lagoon from the sea. Very little information is available to quantify the magnitude of these changes, but from the data available (see Appendix) a range in the vicinity of 2 m is considered normal. Percolation of water through the bar does occur, but the water level drops dramatically once the mouth opens after a heavy rainstorm (Plate 1). The mouth may also be opened (or breached) artificially.

On occasions, factors other than water level influenced the choice of sampling sites. For example where noticeable signs of life became evident (such as the movement of fish visible on the surface; or the

Table 1. Environmental criteria used for the selection of 14 systems to form the basis of a classification scheme.

Estuary type*	ENVIRONMENTAL CONDITION*			Total
	GOOD	FAIR	POOR	
Lagoon	Mhlanga Msimbazi uMgababa Mahlongwa	Zinkwasi Mhlali Mdloti	Tongati Manzimtoti Little Manzimtoti	10
Estuary		Mgeni Lovu Mkomazi		3
Embayment		Durban Bay		1
TOTAL	4	7	3	14

*after Begg (1978)

Table 2. Variation in the environmental character of the 14 systems selected for study in the first two years. This information is based on a review of available data (Begg, 1978), periodic measurements and personal observation.

Name	Size (ha)	Mouth condition *	Salinity **	Dominant peripheral vegetation	Primary evidence of perturbation
Zinkwasi	19	3	2	<u>Phragmites</u>	Heavy siltation
Mhlali	21	3	4	<u>Hibiscus & Sporobolus</u>	Cane encroachment
Tongati	8	2	3	<u>Eichhornia</u>	Industrial/sewage pollution
Mdloti	14	3	4	<u>Phragmites</u>	Artificial breaching
Mhlanga	11	4	4	<u>Phragmites & Potamogeton</u>	Comparatively free
Mgeni	48	1	2	<u>Avicennia</u>	Sewage pollution
Durban Bayhead	73	1	1	absent	Harbour development
Manzimtoti	7	3	4	<u>Phragmites</u>	Urban development
Little Manzimtoti	1	3	4	<u>Eichhornia</u>	Sewage pollution
Lovu	10	2	3	<u>Phragmites</u>	Periodic industrial pollution
Msimbazi	13	4	3	<u>Juncus</u>	Bridge construction
uMgababa	18	3	3	<u>Juncus & Zostera</u>	Bridge construction
Mkomazi	38	1	2	<u>Phragmites & Hibiscus</u>	Flood prone/heavy siltation
Mahlongwa	6	3	3	<u>Phragmites & Bruguiera</u>	Comparatively free

* Mouth condition: 1 = permanently open
 2 = closed for less than 50% of the year
 3 = " " more " 50% " " "
 4 = " " " " 80% " " "

** Salinity: 1 = > 30‰
 2 = 15-30‰
 3 = 5-15‰
 4 = < 5‰

skipping of prawns disturbed by the boat; or the sight of herons actively pursuing fish in the shallows) samples were deliberately taken from these localities as well.



Plate 1. The effect of a sudden water level drop in the Mdloti Lagoon following artificial breaching of the sandbar. This illustrates the impracticality of having fixed sampling stations.

To accommodate the variation in sampling sites, a grid system was designed to superimpose over a map of each study area, thus enabling any site within that system to be identified by cross referencing. The area covered by each square of the grid varied enormously from one study area to the next because the size and scale of each estuary mapped differed.

No more than ten samples were taken on any one visit. At times less than ten samples were taken (Table 3), mainly on account of the size of the system, but also because of physical limitations such as floods, water level fluctuations, hyacinth infestation, sedimentation or even equipment failure.

Table 3 . Variation in the number of samples per trip per system, and overall

SYSTEM	T R I P																						TOTAL N° of SAMPLES
	1	2	3	4	5	6	7	8	9	10	11	12	13	14	15	16	17	18	19	20	21	22	
Zinkwasi	7	8	7	7	7	7	7	9	8	8	9	9	9	7	8	-	-	-	-	-	-	-	117
Nonoti	6	6	6	-	-	-	-	-	-	-	-	-	-	-	-	-	-	-	-	-	-	-	18
Mdlotane	7	6	5	-	-	-	-	-	-	-	-	-	-	-	-	-	-	-	-	-	-	-	18
Mvoti	5	5	5	-	-	-	-	-	-	-	-	-	-	-	-	-	-	-	-	-	-	-	15
Seteni	3	4	5	-	-	-	-	-	-	-	-	-	-	-	-	-	-	-	-	-	-	-	12
Mhlali	8	8	9	8	8	7	8	-	-	-	-	-	-	-	-	-	-	-	-	-	-	-	56
Tongati	6	5	5	4	5	3	4	4	4	3	4	4	7	7	6	-	-	-	-	-	-	-	71
Mdloti	8	8	9	7	7	6	7	7	6	8	7	6	7	7	7	-	-	-	-	-	-	-	107
Mhlanga	7	8	9	7	7	7	7	-	-	-	-	-	-	-	-	-	-	-	-	-	-	-	52
Mgeni	7	9	10	9	10	9	9	10	9	10	9	10	10	10	10	10	10	9	8	8	8	8	202
Durban Bayhead	7	8	8	7	7	7	7	-	-	-	-	-	-	-	-	-	-	-	-	-	-	-	51
Sipingo	3	7	6	8	-	-	-	-	-	-	-	-	-	-	-	-	-	-	-	-	-	-	24
Mbokodweni	5	5	4	-	-	-	-	-	-	-	-	-	-	-	-	-	-	-	-	-	-	-	14
Manzimtoti	5	6	6	6	6	6	6	5	6	6	6	4	6	6	6	-	-	-	-	-	-	-	86
Little Manzimtoti	6	5	6	5	5	5	5	-	-	-	-	-	-	-	-	-	-	-	-	-	-	-	37
Lovu	6	7	7	7	6	6	7	-	-	-	-	-	-	-	-	-	-	-	-	-	-	-	46
Msimbazi	8	10	9	9	8	9	8	8	8	8	8	8	8	8	6	-	-	-	-	-	-	-	123
uMgababa	9	10	8	8	8	7	8	-	-	-	-	-	-	-	-	-	-	-	-	-	-	-	58
Ngane	5	5	4	-	-	-	-	-	-	-	-	-	-	-	-	-	-	-	-	-	-	-	14
Mkomazi	6	7	6	5	4	3	6	6	6	7	8	8	5	8	6	4	3	7	7	6	7	7	132
Mahlongwana	7	7	6	-	-	-	-	-	-	-	-	-	-	-	-	-	-	-	-	-	-	-	20
Mahlongwa	7	7	6	6	6	6	7	6	7	7	6	7	6	7	-	-	-	-	-	-	-	-	91
Mpambanyoni	4	6	5	-	-	-	-	-	-	-	-	-	-	-	-	-	-	-	-	-	-	-	15
Mzimayi	2	4	4	4	-	-	-	-	-	-	-	-	-	-	-	-	-	-	-	-	-	-	14
Mzinto	6	7	7	7	-	-	-	-	-	-	-	-	-	-	-	-	-	-	-	-	-	-	27
Mkumbane	4	4	4	-	-	-	-	-	-	-	-	-	-	-	-	-	-	-	-	-	-	-	12
Sezela	6	5	4	-	-	-	-	-	-	-	-	-	-	-	-	-	-	-	-	-	-	-	15
Mdesingane	4	4	4	-	-	-	-	-	-	-	-	-	-	-	-	-	-	-	-	-	-	-	12
Fafa	8	7	8	-	-	-	-	-	-	-	-	-	-	-	-	-	-	-	-	-	-	-	23
Mvuzi	5	4	4	-	-	-	-	-	-	-	-	-	-	-	-	-	-	-	-	-	-	-	13
Mtwalume	7	6	7	-	-	-	-	-	-	-	-	-	-	-	-	-	-	-	-	-	-	-	20
Mnamfu	5	4	5	-	-	-	-	-	-	-	-	-	-	-	-	-	-	-	-	-	-	-	14
Kwa Makosi	5	4	5	-	-	-	-	-	-	-	-	-	-	-	-	-	-	-	-	-	-	-	14
Mfazazana	5	4	4	-	-	-	-	-	-	-	-	-	-	-	-	-	-	-	-	-	-	-	13
Mhlungwa	6	6	6	-	-	-	-	-	-	-	-	-	-	-	-	-	-	-	-	-	-	-	18
Mhlabatshane	5	5	5	-	-	-	-	-	-	-	-	-	-	-	-	-	-	-	-	-	-	-	15
Mzumbe	5	4	5	-	-	-	-	-	-	-	-	-	-	-	-	-	-	-	-	-	-	-	14
iNtshambili	6	5	5	-	-	-	-	-	-	-	-	-	-	-	-	-	-	-	-	-	-	-	16
Koshwana	5	4	4	-	-	-	-	-	-	-	-	-	-	-	-	-	-	-	-	-	-	-	13
Damba	4	4	5	-	-	-	-	-	-	-	-	-	-	-	-	-	-	-	-	-	-	-	13
Mhlangankulu	6	6	6	-	-	-	-	-	-	-	-	-	-	-	-	-	-	-	-	-	-	-	18
Mtentweni	8	6	6	-	-	-	-	-	-	-	-	-	-	-	-	-	-	-	-	-	-	-	20
Mzimkulu	7	7	7	-	-	-	-	-	-	-	-	-	-	-	-	-	-	-	-	-	-	-	21
Mbango	7	5	5	-	-	-	-	-	-	-	-	-	-	-	-	-	-	-	-	-	-	-	17
Boboyi	4	4	4	-	-	-	-	-	-	-	-	-	-	-	-	-	-	-	-	-	-	-	12
Zotsha	8	7	7	-	-	-	-	-	-	-	-	-	-	-	-	-	-	-	-	-	-	-	22
Mhlangeni	5	5	5	-	-	-	-	-	-	-	-	-	-	-	-	-	-	-	-	-	-	-	15
Vungu	1	2	1	-	-	-	-	-	-	-	-	-	-	-	-	-	-	-	-	-	-	-	4
Kongweni	6	5	5	-	-	-	-	-	-	-	-	-	-	-	-	-	-	-	-	-	-	-	17
Uvuzana	5	4	4	-	-	-	-	-	-	-	-	-	-	-	-	-	-	-	-	-	-	-	13
Bilahlolo	5	5	5	-	-	-	-	-	-	-	-	-	-	-	-	-	-	-	-	-	-	-	15
Mvutshini	4	4	4	-	-	-	-	-	-	-	-	-	-	-	-	-	-	-	-	-	-	-	12
Mbizana	5	6	6	-	-	-	-	-	-	-	-	-	-	-	-	-	-	-	-	-	-	-	17
Kaba	5	5	5	-	-	-	-	-	-	-	-	-	-	-	-	-	-	-	-	-	-	-	15
Umhlangankulu	6	6	6	-	-	-	-	-	-	-	-	-	-	-	-	-	-	-	-	-	-	-	18
Mpenjati	7	6	7	-	-	-	-	-	-	-	-	-	-	-	-	-	-	-	-	-	-	-	20
Kandandlovu	5	5	5	-	-	-	-	-	-	-	-	-	-	-	-	-	-	-	-	-	-	-	15
Tongazi	3	4	3	-	-	-	-	-	-	-	-	-	-	-	-	-	-	-	-	-	-	-	10
Ku-Boboyi	5	5	5	-	-	-	-	-	-	-	-	-	-	-	-	-	-	-	-	-	-	-	15
Sandlundlu	5	5	6	-	-	-	-	-	-	-	-	-	-	-	-	-	-	-	-	-	-	-	16
Zolwane	1	1	1	-	-	-	-	-	-	-	-	-	-	-	-	-	-	-	-	-	-	-	3
Mtamvuna	9	5	5	-	-	-	-	-	-	-	-	-	-	-	-	-	-	-	-	-	-	-	19
TOTAL																							1979

2.2.2 Design of data collection forms

Data sheets were designed to be computer compatible. A map on the back of each sheet enabled the location and direction of each trawl track to be traced.

2.2.3 Sampling frequency

The study commenced in September 1979 so as to coincide with the major recruitment period for estuarine-dependent fish in Natal (Wallace & van der Elst, 1975).

During the first year eight systems were sampled once a month to determine what sort of temporal variation between each sampling interval was apparent.

During the second year of fieldwork an effort was made to sample the two most potentially changeable systems (namely the Mkomazi and the Mgeni) at the same frequency. The remaining six systems were re-sampled every three months as spot checks, and an additional six systems were incorporated into the survey to increase the diversity of the estuaries being studied. These were sampled monthly, other than on those occasions when the original systems (referred to above) were re-sampled.

During 1982, the third year of study, as much time as possible was devoted to the sampling of 48 systems, so that each had been sampled at least three times before the end of the year. This meant that each system was sampled at approximately quarterly intervals.

2.2.4 Sampling gear

A 2,5 m long fibreglass boat (weighing 35 kg) equipped with a 2,5 horsepower Seagull (weighing 17 kg) was used as a means of transport within each estuary.

A 1 m wide beam trawl (Fig.2) was built, similar to that used by Staples and Vance (1979) and de Freitas (1980). The net was of 25 mm stretched mesh and the bag had an outer lining of 12 mm stretched mesh. In the case of manual hauls, the net travelled 2 m behind the operator, whilst in the case of powered hauls, the net travelled 10 m behind the boat. The establishment of the exact distance trawled has always created difficulties (Gunter, 1957; Carney & Carey, 1980), and so the duration of the haul was timed to the nearest 0,25 minute by means of a stopwatch, in order to express the data (as catch per minute trawled) in a form common to each estuary sampled.

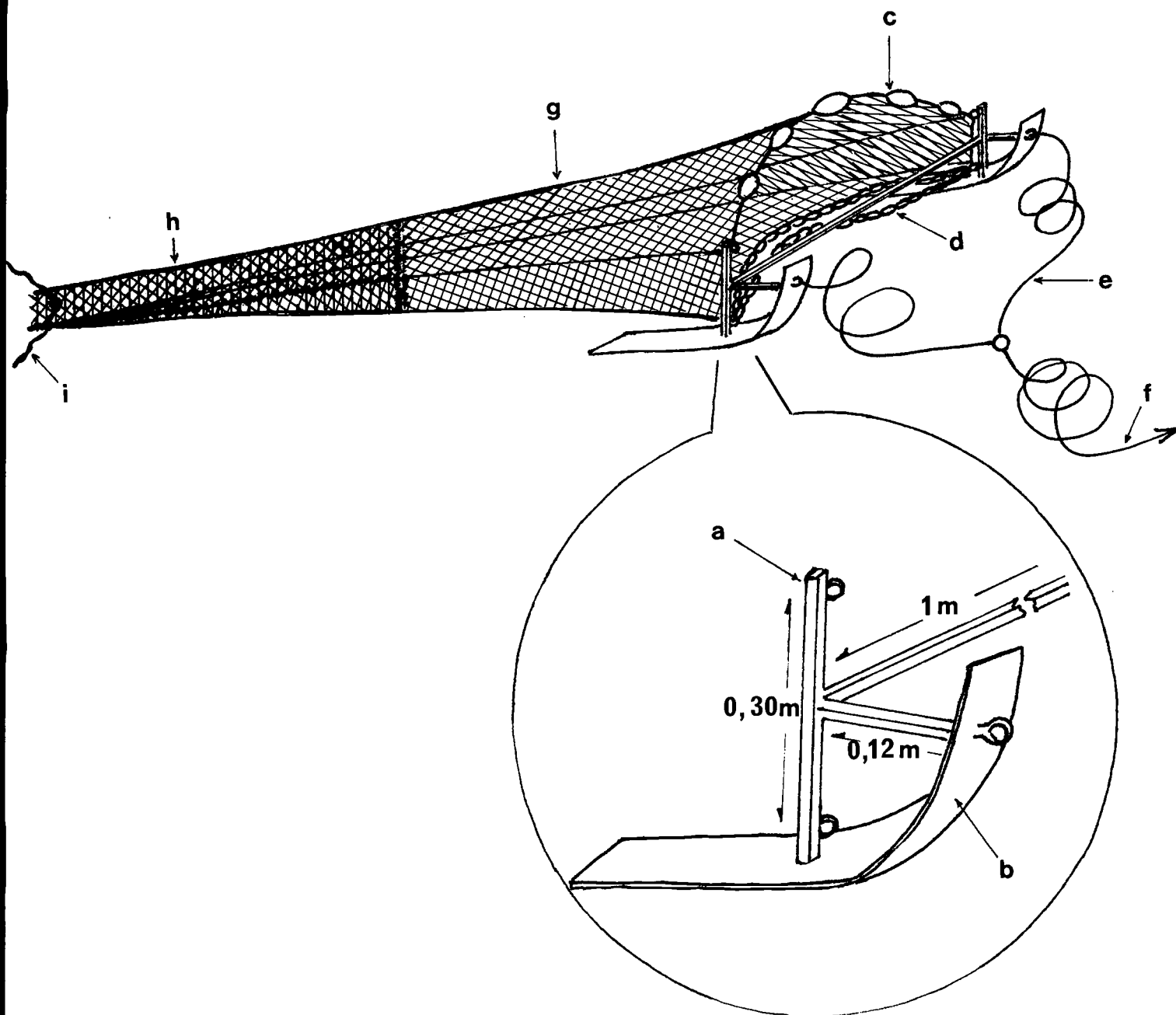

- a** - frame of 25 mm square galvanized steel tubing.
- b** - sledge of 2 mm thick flat iron, 500 mm long x 75 mm wide.
- c** - headrope with 5 small floats.
- d** - tickler chain with a link size of 25 mm.
- e** - 2 m long bridle.
- f** - 8 m long warp.
- g** - 25 mm stretched mesh webbing.
- h** - bag of 12 mm stretched mesh over 25 mm webbing.
- i** - drawstrings

Fig.2. Details of the beam trawl used for sampling.

In practice the net demonstrated that samples could be obtained from a great variety of habitats. For example, it could be drawn over thick mud, in deep areas immediately alongside the edge of densely vegetated banks, over submerged vegetation or up narrow creeks. The net also showed satisfactory replicability (percentage similarity of 62,8%) when trawled over the same pitch on consecutive occasions (Table 4) despite disturbance ahead of the net, and that in the multivariate analysis of communities sample heterogeneity is unavoidable (Gauch,1982).

After a few months it became apparent that water depth had a marked influence on the catch (Table 5). This result was attributed to three factors:

- a) concentration of the biota at low water;
- b) increased vulnerability of the biota at low water by minimizing escape possibilities;
- c) at low water both pelagic and demersal species become trawl susceptible.

Exactly the converse occurred at high water. This significant result implied that there was an optimal time for sampling an estuary by means of a beam trawl, and imposed additional statistical limitations when estimating species abundances between estuaries. Throughout the study however, a concerted effort was made to sample at low water in preference to any other condition (Fig.6).

Diurnal variation in species composition was tested on one occasion in the Mdloti Lagoon (Table 6), and the percentage similarity between samples was shown to average 70,7%.

Experience also showed that the net could not be operated successfully when swiftly flowing water was encountered (e.g. during floods) when the substratum became too soft or overgrown by filamentous algae such as Chaetomorpha.

Wherever trawls were located, water samples were taken for the purpose of measuring certain physico-chemical characteristics (see below). The apparatus used was a simple but most effective sampling bottle designed locally by Rich Engineering (Pty) Ltd (Fig.3). This comprised a copper jacketed cylinder (volume 875 ml) at both ends of which were semicircular valves. These automatically opened as the bottle was being lowered and automatically closed as the bottle was raised. In this way water could be taken from any desired depth by

Table 4. Variation in species composition between six consecutive four-minute trawls over the same pitch in the Manzimtoti Lagoon (9.10.1979). The number of each species caught are in brackets.

Trawl Nº	Number of individuals			
	<u>Metapenaeus monoceros</u>	<u>Dreochromis mossambicus</u>	<u>Gilchristella aestuarius</u>	<u>Glossogobius giurus</u>
1	+ (7)	+ (1)	+ (4)	-
2	+ (5)	+ (2)	-	-
3	+ (1)	+ (1)	+ (4)	-
4	-	+ (5)	-	-
5	+ (9)	-	-	+ (1)
6	+ (5)	+ (2)	+ (2)	-

Percentage similarity between samples ($\times 62,8\%$) determined by the coefficient of community (CC) equation:

$$CC_{jk} = \frac{200S_c}{S_j + S_k}$$

S_j and S_k are the number of species in samples $j + k$, S_c the number of species in common.

Sample	1	2	3	4	5	6
1						
2	80					
3	100	80				
4	50	55	50			
5	40	66	40	0		
6	100	80	100	50	40	

Table 5. Data from the Mdloti lagoon, illustrating the influence of water depth on catchability.

	Low water	High water
Number of samples	30	40
Net effort (minutes)	39	126,75
Total number of species	29	24
Total number of specimens	4265	265
Catch per hour	6561,54	125,44

Table 6. Variation in species composition by night and by day for the same duration of haul over the same trawl track in the Mdloti Lagoon (19 November 1979). The number of each species caught are in brackets.

SPECIES	Grid Ref.		2316		2412		2013		1506		1211	
	Duration of trawl (min)		2,25		2		4		2		4	
	Time of day		Day	Night	Day	Night	Day	Night	Day	Night	Day	Night
<u>Solea bleekeri</u>						+ (1)						
<u>Ambassis natalensis</u>												
<u>Pomadasys commersonni</u>					+ (1)	+ (22)	+ (1)	+ (12)				+ (1)
<u>Rhabdosargus sarba</u>					+ (1)							
<u>Liza macrolepis</u>						+ (1)						
<u>Oligolepis acutipennis</u>			+ (15)	+ (9)	+ (14)	+ (8)	+ (1)					+ (1)
<u>Oreochromis mossambicus</u>			+ (7)	+ (12)		+ (4)	+ (6)					
<u>Penaeus japonicus</u>					+ (2)	+ (1)						
<u>Metapenaeus monoceros</u>			+ (5)	+ (3)	+ (1)	+ (1)	+ (4)		+ (1)	+ (3)		
<u>Sesarma catentata</u>			+ (3)	+ (1)								
<u>Varuna litterata</u>							+ (1)					+ (1)
<u>Scylla serrata</u>				+ (1)								+ (2)
Total number of species in common			4		4		3		1		1	
Percentage similarity ($x = 70,7\%$)			88,9		72,7		75,0		50,0		66,7	

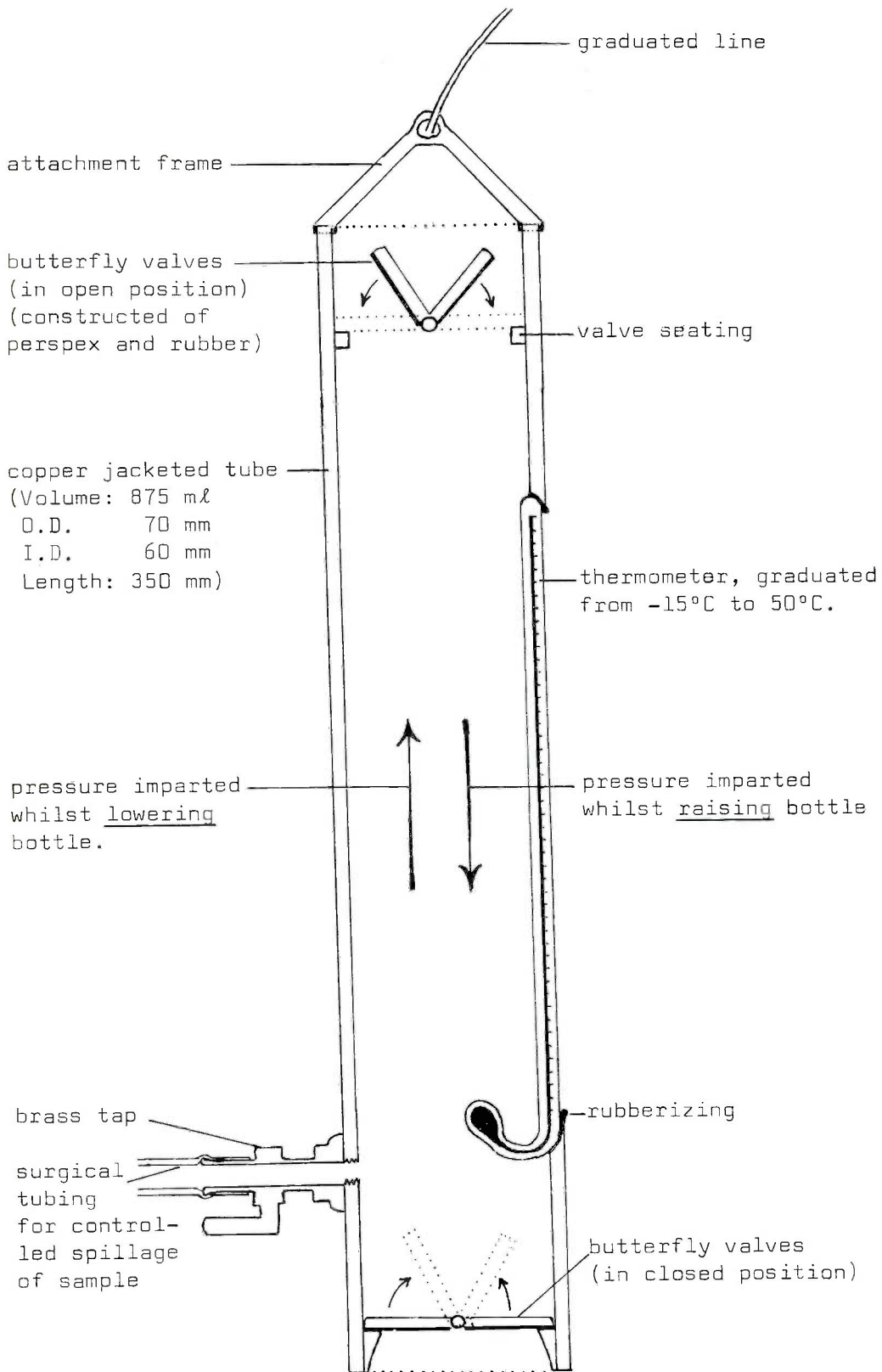

Fig.3. Details of the water sampler used throughout the study period

operating a hand-held graduated line from the surface.

Samples of the substratum were obtained either by hand or by means of a coring device (Fig.4).

2.2.5 Field measurements

At each sampling site the following environmental information was obtained. Depth was measured by lowering one or more graduated drain cleaning rods to the bottom of the estuary. The Winkler technique was used for oxygen determinations (surface and bottom). Salinity (surface and bottom) was measured by means of a hand-held, temperature compensated, refractometer (manufactured by A.O. Goldberg, Model 10423). Water temperature (surface and bottom) was read from a thermometer mounted inside the water sampler (Fig.3). Water transparency was measured by means of a 20 cm diameter Secchi disc, divided into black and white quadrants.

A visual and tactile method of evaluating the nature of the substratum was developed (Table 7) as well as a similarly simple system to evaluate the nature of the influential vegetation in the area of the trawl track (Table 8). A textural classification of 30 samples of the more commonly encountered substrata was conducted so as to relate to the standard techniques used by estuarine workers elsewhere in the country (Table 7 and Fig.5).

All the environmental parameters measured, as well as the 'state' of an estuary (Fig.6), are regarded as the principal abiotic factors likely to affect the kind and abundance of animals occurring there (Day,1967; Blaber & Blaber, 1980) despite the fact that an essential prerequisite for estuarine animals seems to be the ability to tolerate extreme variations in factors of this nature (Day,1981; Whitfield et al.,1981; Schwartz,1981). Because of the sampling technique adopted (namely trawling), the characteristics of the bottom water were naturally the most relevant in terms of relating these to the species caught. Surface readings (where different) provided insight into the degree of stratification in the water body and were useful for estuary classification purposes.

The variability of the environmental parameters recorded during the course of trawling was examined by measuring each parameter immediately before commencing and immediately after terminating each trawl in eight study areas. In all, 54 sampling sites were double checked in this way (Table 9). The results were subjected to a paired

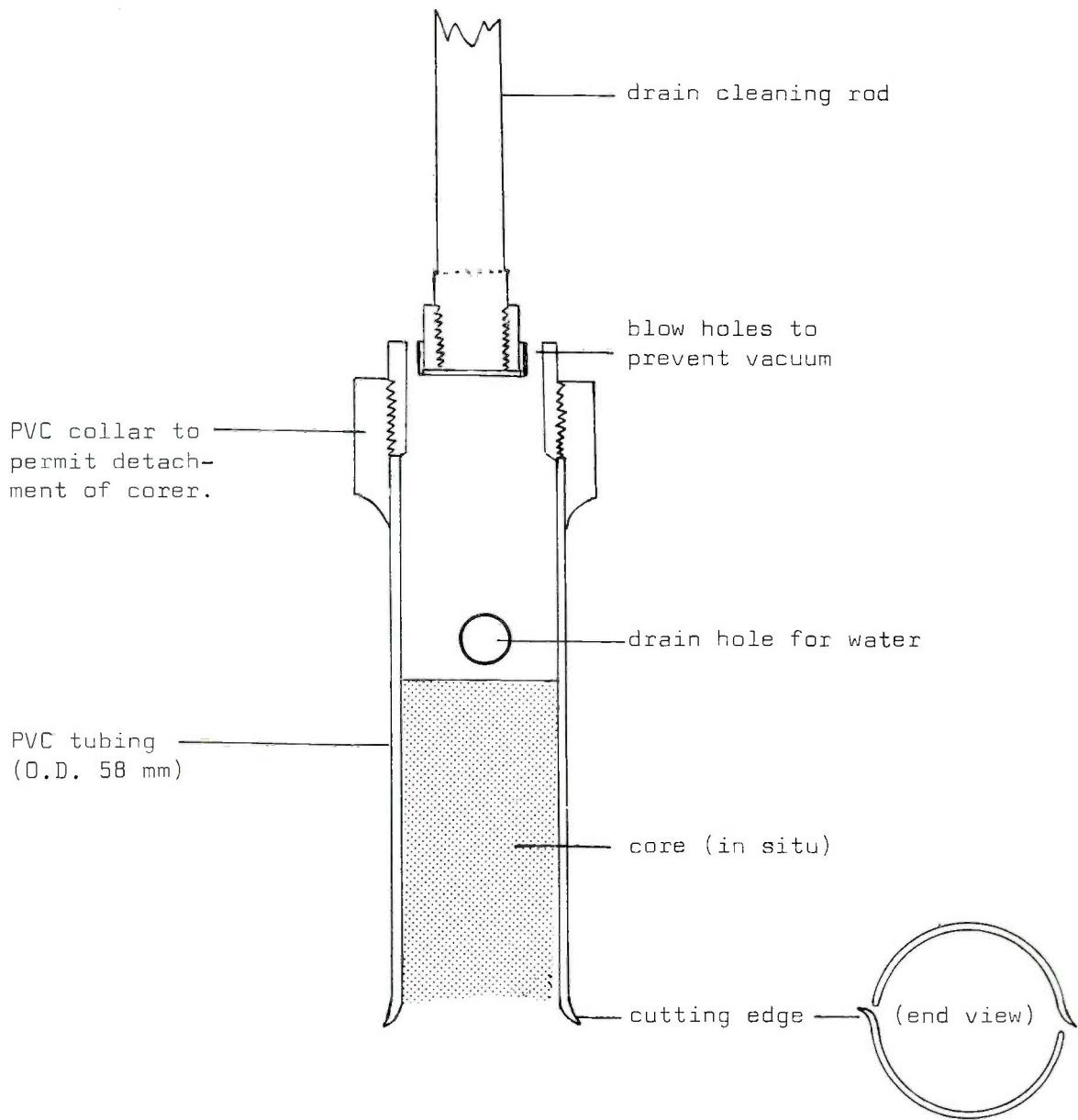

Fig.4. Details of the coring device manufactured to obtain a sample of the substratum at each sampling site.

Table 7. A system devised for classification of the substratum in the area of the trawl track. This was achieved by visual and tactile means whilst crushing a sample of the substratum underwater. The results of particle size analysis for the more commonly encountered substratum types are included. Significant shifts in the mean values are underlined.

SUBSTRATUM	Designation, according to visual and tactile assessment <u>in situ</u>	Particle Size Analysis								
		Origin	% clay	% silt	% sand					Total
					0,02-0,19	0,20-0,41	0,42-0,70	0,71-1,35	> 1,4	
Rocks	Large stones & rocks (often immovable)									
Stones	Small stones & pebbles									
					Not attempted					
Medium-coarse sand	A silt-free, coarse sandy material	Mhlangeni	1,5	4,0	1,8	11,4	15,8	23,9	41,7	94,5
		Mtentweni	6,5	0,5	0,2	0,4	1,3	6,1	85,0	93,0
		Mkumbane	6,5	0,5	1,0	7,7	9,3	14,9	60,3	93,0
		Mhlangenkulu	7,0	0,0	1,4	7,4	8,5	13,8	61,9	93,0
		Mean	5,4	1,0	1,1	6,7	8,7	14,6	<u>62,2</u>	93,4
Fine sand	A silt-free, fine sandy material	Mfazazana	8,0	4,0	19,9	56,6	10,0	1,3	0,3	88,0
		Fafa	2,5	2,5	0,0	0,2	9,0	71,4	14,5	95,0
		Mvuzi	3,0	2,5	2,8	16,8	24,8	39,0	11,7	94,5
		Mhlungwa	1,0	1,5	0,1	1,3	13,7	66,1	16,4	97,5
		Mkumbane	2,5	2,0	10,4	13,3	42,9	35,8	3,0	95,5
Mean	3,4	2,5	6,6	17,6	<u>20,1</u>	<u>42,7</u>	9,2	94,1		
Muddy sand	A sandy material noticeably discoloured by mud	Mdesingane	13,0	2,5	10,3	25,4	28,5	18,4	1,9	84,5
		Kwa-Makosi	7,0	2,0	18,1	32,3	16,4	20,3	4,0	91,0
		Fafa	8,5	0,0	6,8	47,0	25,3	10,9	1,5	91,5
		Mhlungwa	9,5	2,0	24,9	25,4	13,4	12,7	12,1	88,5
		Mkumbane	10,0	0,0	5,6	19,6	21,4	28,5	14,9	90,0
		Mtwalume	9,0	8,5	13,6	32,8	18,8	12,7	4,6	82,5
Mean	<u>9,5</u>	2,5	13,2	30,4	20,6	17,2	6,5	88,0		
Sandy mud	A muddy material with traces of fine sand	Fafa	14,0	3,0	57,0	11,1	5,1	8,0	1,7	83,0
		Mhlangenkulu	15,0	4,0	40,7	19,3	8,6	8,7	3,7	81,0
		Boboyi	18,0	3,5	13,6	28,4	24,7	11,2	0,6	78,5
		Mzumbe	30,5	11,5	39,9	10,9	5,0	1,9	0,4	58,0
		Bilahlolo	31,5	20,5	39,9	2,9	2,3	1,1	1,8	48,0
		Mhlangeni	16,0	11,0	30,5	12,8	10,3	17,2	2,3	73,0
Mean	<u>20,8</u>	8,9	<u>36,9</u>	14,2	9,3	8,0	1,75	70,3		
Silt	A muddy material without traces of sand	Boboyi	37,5	13,5	40,1	5,5	1,6	0,9	1,0	49,0
		Mzimkulu	55,5	36,5	7,1	0,2	0,3	0,2	0,2	8,0
		Mtwalume	44,5	19,0	35,4	0,6	0,2	0,2	0,1	36,5
		Mdesingane	48,0	32,0	19,2	0,4	0,2	0,1	0,1	20,0
		Mean	<u>46,4</u>	<u>25,2</u>	25,4	1,7	0,6	0,3	0,3	28,4
Silty clay	Silt of a stiff and tenacious nature	Mzumbe	55,5	36,5	12,3	0,2	0,1	0,1	0,4	13,0
		Fafa	35,0	16,0	47,8	0,5	0,2	0,2	0,3	49,0
		Mtwalume	35,5	14,5	46,9	1,3	0,7	0,5	0,5	50,0
		Mean	42,0	22,3	35,6	0,6	0,3	0,2	0,4	37,3
Sludge	Fine black ooze generally smelling of hydrogen sulphide	Sezela	33,0	18,0	34,0	4,3	2,5	3,2	5,0	49,0
		Mvuzi	35,0	4,0	36,3	16,8	3,9	2,4	1,6	61,0
		Mean	34,0	11,0	35,1	10,6	3,2	2,8	3,3	55,0
Silt-capped sand	Sand overlain by a few centimetres of silt									
Sand-capped silt	Silt overlain by a few centimetres of sand									
Algal turf	Any of the above substrates that become smothered by filamentous algae									
Macrophytic debris	Any of the above substrates that become smothered by debris (such as leaf litter) originating from peripheral vegetation									

Table 8. Simplified method of classifying by sight the nature of the influential vegetation in the area of the trawl track.

VEGETATION TYPE	TYPICAL EXAMPLES
Barren (devoid of vegetation)	along the edge of a sandbar
Filamentous algae	<u>Chaetomorpha</u>
Submerged macrophytes	<u>Potamogeton</u> ; <u>Zostera</u> ; <u>Ruppia</u>
Reeds	<u>Phragmites</u>
Grasses	<u>Sporobolus</u> ; <u>Stenotaphrum</u>
Sedges	<u>Juncus</u> ; <u>Scirpus</u>
Lagoonal trees	<u>Hibiscus</u> ; <u>Barringtonia</u>
Estuarine trees	<u>Avicennia</u> ; <u>Bruguiera</u>
Coastal trees	<u>Casuarina</u> ; <u>Mimusops</u>
Riverine trees	<u>Ficus</u> ; <u>Voacanga</u>
Infestant macrophytes	<u>Eichhornia</u>
Dune pioneers	<u>Scaevola</u>

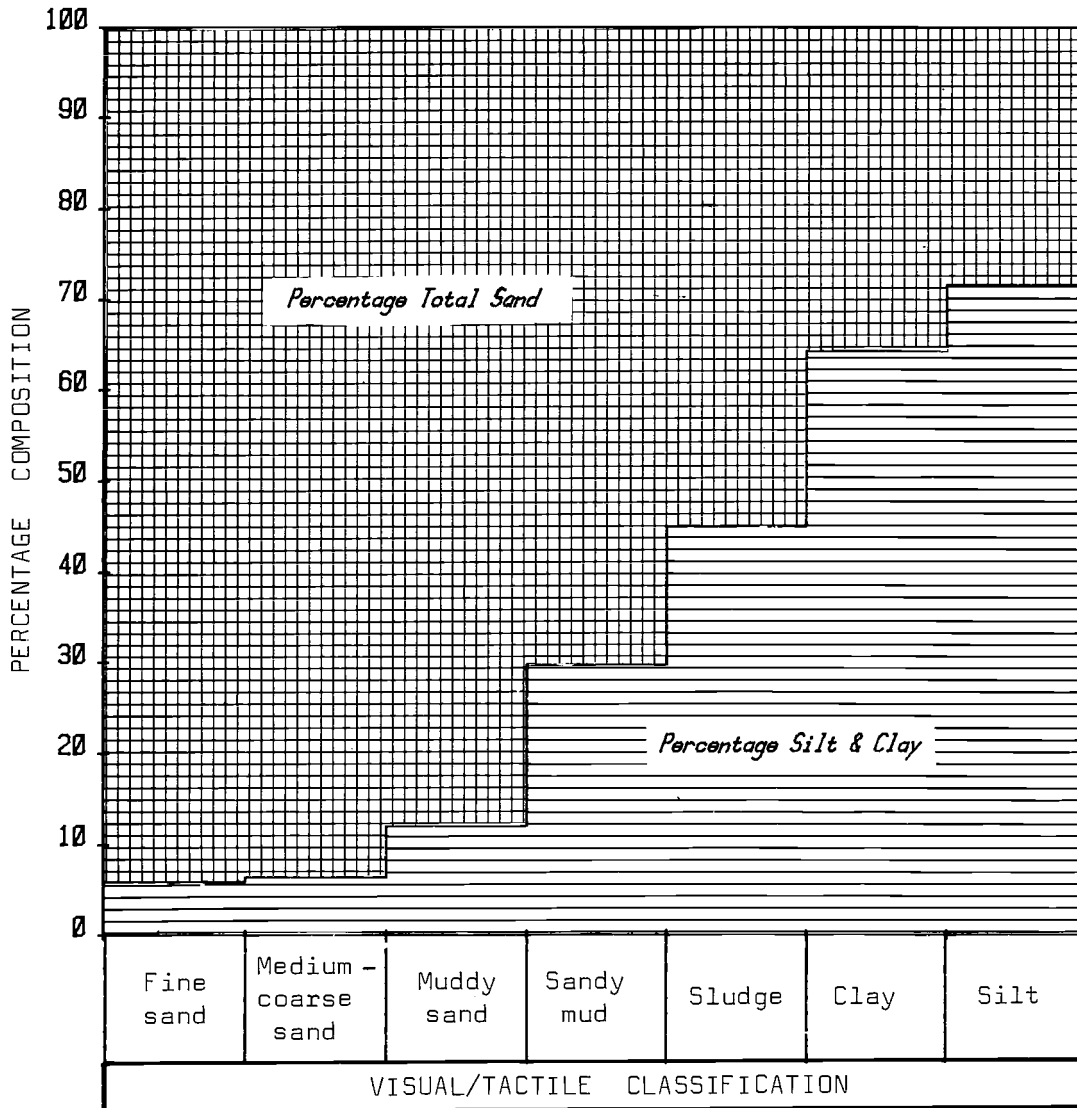

Fig. 5 The relative proportions of sand and silt fractions in the more commonly encountered types of substrata in estuaries and lagoons. The data are derived from Table 7.

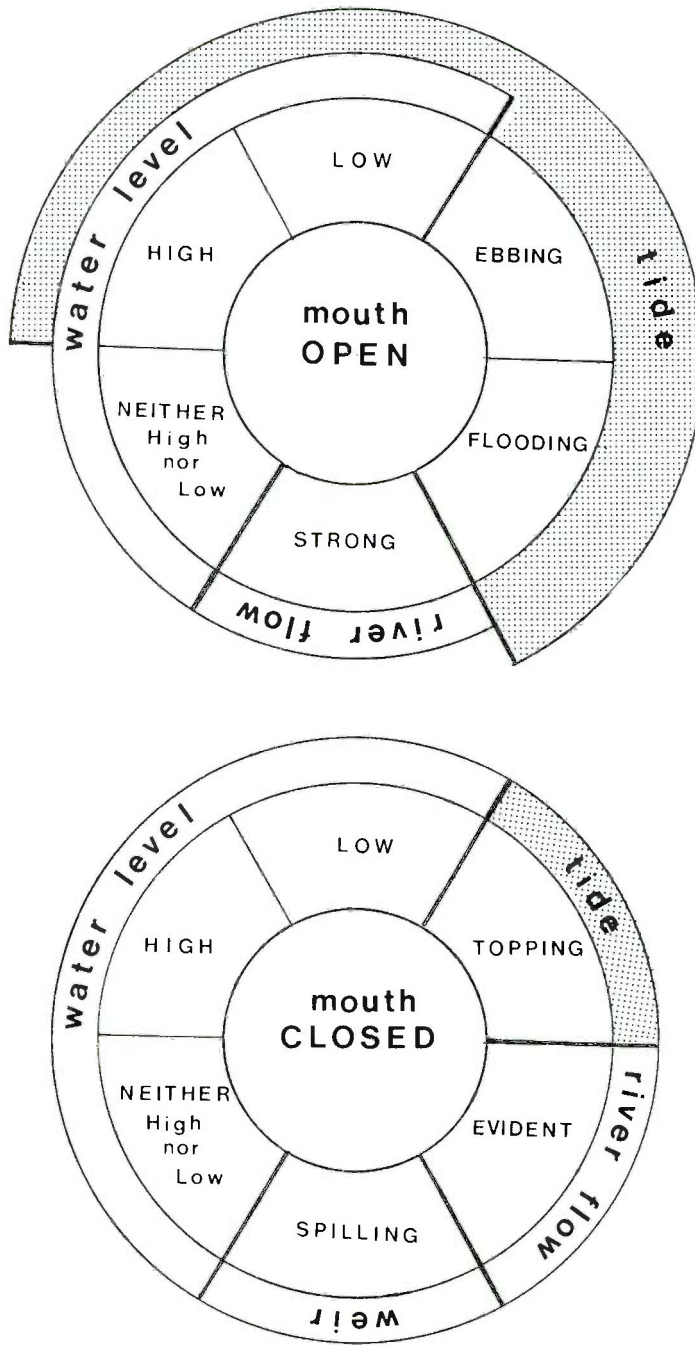

Fig.6. Schematic representation of the twelve principal hydrological events affecting the environmental character of the systems studied. Each of these were regarded as a different 'state' and coded separately for computation purposes.

Table 9. Variability of environmental data at the start and finish of 54 trawl tracks. Values underlined are significantly different at a 95% level of confidence. Dashes (-) under Secchi imply water transparency was in excess of the depth indicated.

SYSTEM	Distance trawled (m)	DEPTH (cm)		DISSOLVED OXYGEN (mg/l)				SALINITY (‰)				TEMPERATURE (°C)				SECCHI (cm)	
				Surface		Bottom		Surface		Bottom		Surface		Bottom			
		start	finish	start	finish	start	finish	start	finish	start	finish	start	finish	start	finish	start	finish
MGENI	175	85	65	4,6	4,4	6,3	6,0	6	10	32	30	20,4	20,5	22,3	22,2	65	50
	225	90	105	3,9	4,2	4,4	4,0	14	10	30	30	21,8	20,4	22,4	22,1	40	35
	200	160	140	4,0	4,1	4,4	5,1	6	6	29	30	20,8	20,8	22,1	22,0	30	30
	175	70	60	4,5	4,6	5,1	5,3	10	10	28	28	22,1	22,0	22,6	22,6	45	45
	300	55	50	5,8	5,3	5,0	5,1	15	15	28	25	23,7	23,7	23,3	23,1	40	40
	75	100	20	5,3	5,2	5,0	5,2	14	14	21	14	23,1	23,1	23,0	23,1	-	-
	25	10	0	9,1	9,3	9,1	9,3	5	5	5	5	25,0	25,2	25,0	25,2	-	-
	75	25	0	7,5	7,1	7,5	7,1	22	22	22	22	24,3	24,3	24,3	24,3	-	-
	15	30	30	5,2	5,2	5,2	5,2	12	12	12	12	22,7	22,7	22,7	22,7	-	-
	200	80	95	5,2	5,2	5,2	5,0	10	10	12	16	22,5	22,7	22,4	22,5	40	40
MDLOTI	225	175	140	6,3	7,0	6,1	7,0	2	2	2	2	21,7	21,9	21,0	21,3	145	120
	200	170	190	7,1	7,2	7,1	6,8	2	2	2	2	21,5	21,6	21,3	21,1	90	95
	75	290	160	7,0	7,2	6,6	7,0	2	2	2	2	21,3	21,4	20,9	21,0	90	90
	150	200	175	4,9	5,1	6,2	6,2	2	2	2	2	22,6	21,8	21,2	21,0	125	110
	30	120	70	4,2	4,0	3,9	4,0	2	2	2	2	23,2	23,5	22,9	23,0	-	-
	175	185	170	4,7	5,0	4,6	4,6	2	2	2	2	23,0	23,1	22,6	22,5	105	100
	500	210	180	6,9	7,3	7,0	7,1	1	1	1	1	22,8	22,8	22,2	22,5	110	100
M5IMBAZI	125	105	90	7,7	7,6	7,5	7,6	13	13	13	13	20,0	20,0	19,5	19,6	-	-
	100	60	0	8,2	8,3	8,0	8,3	14	14	14	14	20,0	20,5	19,8	20,5	-	-
	150	70	60	8,0	7,8	6,8	7,3	14	14	14	14	21,0	21,0	20,6	20,7	-	-
	125	55	50	6,2	7,3	5,9	6,9	14	14	14	14	21,4	21,1	20,6	20,7	-	-
	175	100	85	8,3	8,1	8,4	8,3	15	15	15	14	21,1	21,2	20,7	20,6	70	80
	75	110	95	8,0	7,8	7,2	7,3	13	13	13	13	22,0	22,1	21,6	21,6	50	65
	125	215	140	6,8	7,4	6,0	7,1	12	12	12	12	22,2	22,1	20,1	21,6	105	100
	40	10	0	7,8	8,0	7,8	8,0	12	12	12	12	24,6	24,7	24,6	24,7	-	-
TONGATI	100	250	195	5,8	6,0	0,7	1,1	10	10	29	25	20,3	20,4	24,4	24,0	85	85
	25	25	0	7,3	7,3	7,3	7,3	10	10	10	10	20,9	20,9	20,9	20,9	-	-
	30	40	0	6,8	7,0	6,8	7,0	10	10	10	10	20,9	21,0	20,9	21,0	-	-
	100	140	165	7,0	7,0	3,8	2,9	10	10	24	24	20,9	20,9	22,7	23,1	85	85
ZINKWASI	30	60	0	5,4	5,3	5,1	5,3	27	27	28	27	23,1	23,1	23,0	23,1	-	-
	250	130	125	6,3	6,5	5,9	6,1	29	28	28	28	23,3	23,4	23,0	23,0	40	40
	175	100	110	6,6	6,4	6,4	6,1	28	28	28	28	23,8	23,8	23,1	23,0	45	45
	50	40	30	7,5	7,3	7,5	7,3	29	29	29	29	23,8	23,8	23,8	23,8	-	-
	400	130	110	6,7	6,6	6,1	6,3	28	29	28	28	24,2	24,7	24,0	24,3	50	50
	300	130	170	6,0	6,2	5,8	5,4	28	28	28	28	24,7	24,8	24,5	24,4	55	60
	300	135	145	5,7	5,5	5,3	5,1	28	28	28	28	25,0	25,1	23,8	23,4	70	70
MANZIMTOTI	100	75	60	7,0	8,0	7,0	7,5	5	6	5	6	23,1	23,0	23,0	23,0	40	40
	100	55	65	9,2	9,0	9,2	9,0	7	7	7	7	23,9	23,7	23,9	23,7	40	40
	200	150	110	8,5	8,9	6,3	7,6	5	5	5	5	24,2	24,4	23,4	23,7	40	40
	150	120	135	8,1	7,8	4,1	5,3	5	5	5	5	25,3	25,0	23,4	23,4	35	35
	125	70	85	7,8	8,0	7,6	7,6	4	4	4	4	24,5	25,0	24,4	24,5	30	30
MKOMAZI	125	80	65	7,8	7,6	7,5	7,6	0	0	12	10	21,7	21,7	21,9	21,7	-	-
	250	120	110	7,7	7,5	6,9	7,1	0	0	26	26	21,8	21,8	23,1	23,1	90	90
	50	10	10	7,8	7,8	7,8	7,8	0	0	0	0	21,6	21,6	21,6	21,6	-	-
	200	115	135	8,0	7,8	6,2	6,8	0	0	24	24	21,8	21,8	23,4	23,2	75	75
	125	160	115	7,9	8,0	7,7	7,5	0	0	20	18	21,8	21,7	23,2	23,0	75	75
	35	50	30	5,7	5,9	5,1	5,9	4	4	4	4	22,4	22,1	22,2	22,1	-	-
MAHLONGWA	40	40	0	8,3	8,5	8,3	8,5	26	26	26	26	27,3	27,3	27,3	27,3	-	-
	100	125	40	5,4	5,1	5,6	5,6	26	26	26	26	24,3	24,5	23,6	24,3	-	-
	75	115	60	4,5	4,1	4,0	2,9	26	26	26	26	24,4	24,2	23,8	24,0	-	-
	200	120	120	4,7	4,5	4,4	4,3	26	26	26	26	24,6	24,6	24,3	24,0	105	90
	175	115	105	4,2	4,4	3,9	4,0	25	25	25	26	24,6	24,9	24,1	24,0	80	70
	15	30	30	4,5	4,5	4,5	4,5	25	25	25	25	25,5	25,5	25,5	25,5	-	-
	150	80	55	4,1	3,5	3,0	3,2	24	24	24	24	27,0	27,1	26,6	27,0	-	-
Difference on Average	D	19,17	0,04	0,14	0,02	0,28	0,01	0,05	2,19								
Standard Deviation	S.D.	31,09	0,33	0,46	0,81	1,39	0,05	0,30	7,61								
t		<u>4,53</u>	0,92	<u>2,17</u>	0,17	1,47	0,29	1,36	1,63								
Probability	P	< 0,05	> 0,05	< 0,05	> 0,05	> 0,05	> 0,05	> 0,05	> 0,05								

't' test to determine the significant difference and showed, with a 95% degree of confidence, that with the exception of depth ($P \leq 0,05$) and bottom oxygen ($P \leq 0,05$) the measurements taken at a single point of the trawl track are representative of conditions during the trawl. The depth differed because of natural variation in the bottom profile, and bottom oxygen values probably varied because of biological activity in the sediment creating an oxygen demand at the substratum interface.

For the determination of dissolved oxygen (D.O.) in the field, Gardner (pers.comm.) suggested the use of the standard Winkler method but without going to the point of using refined equipment normally employed in a laboratory. For example:

- a) adding in excess of 2 ml of each Winkler reagent, by displacing that volume from the neck of the D.O. bottle with the glass stopper;
- b) using a measuring cylinder for the purpose of gauging the required volume from the D.O. bottle; and
- c) using a pipette (instead of a burette) for the titration itself.

A comparison of the two techniques was carried out to determine what sort of error may result from taking liberties of this nature, and discrepancies of 0,1 mg/l to 0,2 mg/l were detected. These were considered to be insignificant from a biological point of view.

2.2.6 Specimen recovery and preservation

On termination of a trawl the contents of the bag were placed in a wooden screen (400 mm x 400 mm) with a 4 mm bar stainless steel mesh with an aperture size of 3 mm. The contents of the bag were sifted through and, if feasible, all specimens were identified and counted in situ so as to prevent needlessly killing the animals. If, for a number of reasons, this was not feasible, the specimens were transferred into a bucket before being placed in a labelled plastic bag and stored on ice for transport to the laboratory. If analysis of the samples was not possible the same day, specimens were kept overnight in a deepfreeze.

2.3 Laboratory methods

2.3.1 Species identification

With the exception of one crab, every animal was identified to species level and the total number of species counted. In the knowledge that juvenile organisms are difficult to identify because of their size, experts were consulted and references (Barnard, 1950; Smith, 1935, 1938, 1959, 1965; Day, 1969; van der Elst & Wallace, 1976; de Freitas, 1972, 1980) were used for the purpose of ensuring accurate species identification. However, taxonomic aids for the identification of juveniles were found lacking because emphasis has been given by most workers to a description of adult characteristics. All of the unusual specimens collected, especially fishes of the family Gobiidae (one of which was new to Africa and another new to Southern Africa) were lodged with the J.L.B. Smith Institute of Ichthyology. Although warned much too late to remedy the problem, and in common with other workers, failure to distinguish between Oligolepis acutipennis and O. keiensis meant lumping of these two species has occurred (M. Smith, pers.comm.). In addition, failure to appreciate the existence of a third species of ambassid (Ambassis gymnocephalus) has meant confusion with A. productus could have occurred in localities such as Durban Bay (Martin, pers.comm.).

2.4 Data analysis

The data collected for this study were stored on a Hewlett Packard computer (Model 9825) which facilitated extraction of the data as specified subsets of information in the form of basic listings, tabulations or graphic displays, for any time (year(s), month(s) or season(s)), estuary or physico-chemical specification. Certain facets of these data were transformed into a punchcard format in order to make use of programs for multivariate analysis stored on the Univac 1100 at the University of Natal and University of Cape Town.

2.4.1 Multivariate data analysis

In recent years considerable advances have been made with the aid of computers in the simultaneous examination of environmental variables by multivariate analysis. The purpose of multivariate analysis is to provide a means of treating "...multivariate data as a whole, summarizing the data and revealing their structure" (Gauch, 1982). For the purposes of this study, three of the most commonly

used methods available to ecologists were used. Each was complementary to the other and had the common goal of "organizing data for the purpose of description, discussion, understanding and the management of communities."(Gauch, 1982). Further details of each method are provided in Chapter 4 (Sect. 4.2) but are briefly defined below:

a) **Ordination**

For the purposes of ordination a computer program known as DECORANA (DEtrended CORrespondence ANALysis) was used. This was developed at the Department of Ecology and Systematics, Cornell University, by Hill (1979b).

b) **Cluster analysis**

The final technique chosen for cluster assignment was "ordination space partitioning" having originally been developed by Roux and Roux (Gauch,1982: 200).

c) **Gradient analysis**

For the purposes of examining the influence of various environmental variables in the multi-species relationships defined by DECORANA, the strategy recommended by Field et al. (1982) was adopted. An overlay technique was used to independently examine each environmental variable by superimposing these data over the ordination.

CHAPTER THREE

AN OVERVIEW OF THE RESULTS CONTAINED IN THE APPENDIX

In 1978 Natal Town and Regional Planning Report Vol.41 "The Estuaries of Natal" was published as an inventory of available information on 73 estuaries in the Province and of those factors and forces that had been responsible for their degradation (Begg 1978). This was followed by a second phase (Nov 1978 - Mar 1979) during which the sole objective was to prepare a policy statement (NTRP Report Vol.43) which would help eliminate the stresses already imposed upon this resource. During the period April 1979 to March 1984, a third phase was launched aimed at initiation of the Siyaya Catchment Project (an exercise in estuary rehabilitation), filling of the data voids purposely identified during Phase 1, and at reassessing the present day nursery function of Natal's smaller estuaries.

The Appendix has been written to serve as a supplement to NTRP Report Vol.41 in an endeavour to meet the second of these objectives. It is aimed at updating, correcting and improving that edition. The report systematically deals with each of 62 poorly studied estuaries that lie south of the Tugela (Fig. 1) by documenting the information collected during the study period; and reviewing any additional literature that has since become available. The information content of the maps drawn of each estuary has also been improved upon.

This chapter is an overview of the data presented in the Appendix but for the purposes of this exercise the word 'estuary' will be used loosely to describe each of the systems studied. The numbering system used in the text (3.1-3.62) refers to the code number given to each system in the Appendix, beginning with the Zinkwasi (3.1) in the north, and ending with the Mtamvuna (3.62) in the south.

Size

Despite the fact that the 'boundaries' that determine the area of an estuary are insubstantial, the most striking difference between the estuaries studied was their size (Table 10). Within the study area were systems as small as the Mkumbane (3.26) which is only 0,3 ha in extent and as large as the Mzimkulu (3.43) which is approximately 74 ha in extent. Although Durban Bay (3.11) was purposely chosen as one of the estuary types being studied, only the Bayhead region (73 ha in extent) was involved because it was beyond the capabilities of the sampling gear being used to work in an expanse of water as large as Durban Bay itself. Within the study area, there are also numerous estuaries even smaller than the Mkumbane (such as Adam's Spruit), which have never been studied, but in keeping with the project objectives no attention was given to them because of their miniscule proportions. Attention should also be drawn to the fact that in a river mouth such as the Mvoti (3.4) there is no landward limit and so its area cannot really be defined.

Mouth condition

Another striking feature of the estuaries studied was the variation which occurred as far as contact with the ocean was concerned. Some of the estuaries were permanently open either because of protective works at their mouths, such as the breakwaters of Durban Bay, or the groyne at the mouth of the Mgeni (3.10); or because of discharge characteristics of the river as in the Mkomazi (3.20). However, the majority of the estuaries studied experience intermittent contact with the sea because of sandbar formation across their mouths. This wellknown feature of the Natal coastline (Barnes,1980) is caused by the substantial transport of sand by littoral drift, itself resulting from the prevailing southeasterly swells. Some of the estuaries studied such as the Mahlongwana (3.21), remain closed for many years while others experience frequent contact with the sea. Opening of the mouth normally occurs after enough rain has fallen to create a rise in water level sufficient to breach the bar, although breaching can also result from overtopping of the bar by the sea.

In many cases (as in the Mdloti (3.8)), as the system fills, the surrounding croplands or properties are flooded, which is not acceptable to the owners, and so the bars are artificially breached to

lower the water level. In the Seteni (3.5) however, artificial closure of the mouth occurs to prevent exploitation of the fish population at a time when they are most vulnerable to netting.

The geomorphology of the coastline plays an important role in determining the estuary mouth position. Rock outcrops and headlands provide updrift protection against sand deposition and also affect the periodicity and duration of contact with the sea. The presence of rock sills beneath the sandbar is also a common feature, as is the fact that these sills often regulate the outflow and inflow of water. In several instances (for example the Boboyi (3.45)) estuaries appear to be 'perched' above sea level with the result that tidal influences are non-existent or negligible.

Depth

Considerable variation in depth was also noted amongst the estuaries studied. Eleven were less than 1,0 m deep (on average) and only nine were deeper than 2,5 m. The shallowest of all was the Mvoti, averaging approximately 0,35 m due entirely to infilling of the estuary basin with sediment. This has resulted in raising of the bed level of the system to above sea level, and so tidal exchange cannot occur. In contrast the excessive depth of the Vunqu Estuary (3.48) (estimated by divers to be approximately 40 m deep) proved to be too great for a thorough and effective investigation to be undertaken. Consequently the deepest estuary studied was the Mtamvuna (3.62) which is over 10 m deep in places.

Salinity

An enormous range in salinity was also experienced and although it can be misleading to use average values (because the range in salinity is generally accepted as a more meaningful ecological determinant), certain estaries were considerably more saline than others. The most saline of all was Durban Bayhead due to its direct exposure to the sea, whilst at the opposite end of the scale was the Mvoti, which remained totally fresh throughout the study period. Between these two extremes was a complete range of oligohaline ($\sim 0,5\%$ to $\sim 5,0\%$), mesohaline ($\sim 5\%$ to $\sim 18\%$) and polyhaline ($\sim 18\%$ to $\sim 30\%$) systems. Generally speaking those estuaries open to the sea exhibited the highest salinity. However, certain closed estuaries such as the Zinkwasi (3.1) were extraordinarily saline, whilst others which are normally open (such as the Mzumbe (3.37)) remain fresh.

Great variation in respect of homogeneity of the water column was also experienced (Table 11). Salinity stratification was not necessarily confined to open estuaries in which tidal influences accounted for vertical layering. Stratification was also regularly encountered in closed systems where, due to overtopping of the bar and over-protection from the wind (which is the primary mixing mechanism in such systems), the salinity of the bottom water was often found to be much greater than that at the surface. The Mvuzi (3.30) is an example of a secluded, closed system in which stratification is normally characteristic.

Dissolved oxygen

The amount of dissolved oxygen in the water at both the surface and the bottom of each estuary was found to vary primarily as a result of pollution. In certain cases industrial contamination accounted for estuaries such as the Sezela (3.27) being permanently anaerobic. The bottom water in the Sipingo (3.12) and Tongati (3.7) were similarly affected although to a slightly lesser degree. In some closed estuaries such as the Mbango (3.44) and Mlotane (3.3) the bottom water was found to be lacking in oxygen because of poor circulation due to protection from the wind and the decomposition of leaf litter, both of which are features attributable to the nature of its peripheral vegetation. On the whole, however, oxygen stress was detectable in only seven of the estuaries studied. At the opposite end of the scale, the Mbookodweni (3.13) was oxygen-saturated during the day due to sewage enrichment and the photosynthetic activity of algae.

Water transparency

Natal's estuaries are also wellknown for their turbidity (Day, 1981) and yet considerable variation in Secchi disc readings as a measure of light penetration was encountered. Generally speaking water transparency was reduced in the larger, open estuaries by virtue of the fact that they receive large rivers known to carry high silt loads. Secchi disc measurements from 30 of the estuaries studied were lower than 100 cm, whilst in 32 of them this value was normally exceeded. In all systems water transparency naturally fell during the rainy season whilst the rivers were flowing. The converse applied in winter, when the water was often sufficiently clear in many of the closed systems, for the bottom to be visible. In certain estuaries,

Table 11. The variation in mouth condition, water level, salinity and water transparency at the deepest point of a typical range of estuaries and lagoons along 44 km of the Natal coastline in September 1982. This gives some impression of the different nature of each system at a given point in time.

Day of month	System	Mouth condition	Water level	Salinity (‰)		Transparency Secchi (cm)
				T	B	
13	Fafa	C	N	0	0	80
13	Mvuzi	C	N	4	10	90
14	Mtwalume	C	N	2	11	*
14	Mnamfu	C	N	8	20	*
15	Mfazazana	C	N	3	10	115
15	Kwa-Makosi	C	H	10	26	*
22	Mhlungwa	C	H	0	0	120
21	Mhlabatshane	C	H	13	25	175
21	Mzumbe	C	N	1	20	40
21	iNtshambili	C	N	0	0	90
20	Koshwana	C	N	16	21	*
20	Damba	C	H	8	19	*
27	Mhlangamkulu	C	N	5	7	160
27	Mtentweni	C	H	8	8	155
28	Mzimkulu	O	N	2	26	45
28	Mbango	C	N	2	27	85
29	Boboyi	O	L	3	3	110
29	Zotsha	C	N	8	8	130

Mouth condition: O = open
C = closed

Water level: H = high
N = normal
L = low

Transparency: * = bottom visible

Salinity: T = top
B = bottom

such as the Mbookodweni (where high algal densities occurred), the Sezela (which is industrially polluted) and the iNtshambili (3.38) (which is stained by humic materials), variation in water transparency occurred for other reasons.

Having already emphasized the dynamic nature of estuaries as an aquatic environment (Chapter One) it must be emphasized that none of the features listed in Table 10 as characteristic, are necessarily absolute. The mouth of a normally open estuary can close; or the salinity can alter within a few hours in accordance with river flow; a clear system can be transformed into a turbid system after a single rainstorm, and at the height of the equinoctial spring tide a water body of normally low salinity can be considerably increased by overtopping of the sandbar. Many changes of this nature were noticeable throughout the study period, but are commented upon in greater detail in the Appendix.

Substratum type

During the course of the study, variation in the nature of the substrata underlying each estuary was noted. The most commonly encountered condition was for the bottom to be covered by muddy sand of fluvial origin (refer to Fig.5 in Sect. 2.2.5 of Chap.2). This type of substratum prevailed in 30 of the 62 estuaries studied. In 13 of the remaining systems a noticeably greater proportion of mud occurred together with the sand, whereas silt deposits (containing less than 30% sand) occurred in 14 of the estuaries studied. The tendency for silt to accumulate in backwater areas and in estuaries characterized by a high salinity was noted. This is due in the first instance, to the settling out of suspended materials in areas where water velocities are reduced and in the second instance, to flocculation in the presence of sea water. Sludge deposits were encountered in five systems and, where present (as in the Sezela and Sipingo for example), were generally a direct result of pollution. The floor of only two of the estuaries studied (the Zolwane (3.61) and Tongazi (3.58) were found to be rocky in nature. It was fortunate that so few systems had this characteristic because in neither case was sampling of the system by means of a beam trawl practical.

Flora

The botanical characteristics of each estuary differed, although by far the most commonly encountered type of vegetation was reeds

(Phragmites australis). These plants characterized 55% of the estuaries studied. Sedge dominated systems such as the Mpenjati (3.56) were far less numerous (5%). The trees found alongside each estuary varied from true mangroves (Avicennia marina and Bruguiera gymnorhiza) in the Mgeni for example, to lagoon hibiscus (Hibiscus tiliaceus) in the Mhlabatshane (3.36), to freshwater mangroves (Barringtonia racemosa) in the iNtshambili. In others, such as the Mvutshini (3.52) and Tongazi (3.58) coastal forest grows down to the water's edge. Certain systems were dominated by grasses as a principal vegetation type. For example, the Nonoti (3.2) is characterized by antelope grass (Echinochloa pyramidalis) whereas in the Mhlali (3.6) swards of vlei grass (Paspalum vaginatum) and buffalo grass (Stenotaphrum secundatum) is typical. In none of the estuaries studied were submerged macrophytes dominant, although wherever these plants were found special note was taken of their occurrence. The uMgababa (3.18) was the only estuary surveyed in which eelgrass (Zostera capensis) occurred, whilst fennel-leaved pondweed (Potamogeton pectinatus) was more common in, for example, the Nonoti and the Mhlungwa (3.35). In the Mahlongwana, thick beds of saw-weed (Najas marina) were discovered. A general impression gained during the course of the study was that submerged macrophytes seemed to occur in those systems where the water level was stable because of their semi-permanently closed condition. In terms of energy inputs in closed systems where macrophytes were absent, filamentous algae (Chaetomorpha sp.) seemed to play an important role, especially as blooms occurred in winter whilst water transparency was maximal, and thereby contributed energy to the system at a time when other sources were at a minimum.

Fauna

Particular attention was given to assessing the nature of the fauna in each of the systems studied, by means of the trawl gear described in Chapter Two. In addition, notes were taken of the birdlife encountered, and also the molluscs and some of the insects caught by trawling, but no effort was made to quantify these results. Instead, emphasis was given to the variety of fishes, prawns and crabs caught by trawling.

In all a total of 76,8 hours were spent trawling and a total of 80 515 specimens of 125 different species were caught (Table 12,

Table 12. Relative abundance (in catch per minute) of 125 trawl susceptible species from 62 estuaries and lagoons south of the Tugela River.

MARINE ELASMOBRANCHS and TELEOSTS	Zinkwasi	Nonoti	Mdlotane	Mvoti	Seteni	Mhlali	Tongati	Mdloti	Mhlenga	Mgeni	Durban Bayhead		
<u>Dasyatis uarnak</u>						0,007							
<u>Elops machnata</u>	0,006												
<u>Megalops cyprinoides</u>													
<u>Gilchristella aestuarius</u>	2,120	0,356	0,136	0,124	1,580	0,534		0,319	0,079	0,027			
<u>Stolephorus commersonii</u>										0,090			
<u>Bothus pantherinus</u>	0,039					0,045		0,003		0,070	0,012		
<u>Solea bleekeri</u>	0,428					1,960	0,062	0,052	0,067	2,570	0,285		
<u>Paraplagusia bilineata</u>	0,003												
<u>Syngnathus djarong</u>	0,003									0,022	0,006		
<u>Fistularia petimba</u>										0,001			
<u>Callionymus marleyi</u>										0,005			
<u>Terapon jarbua</u>	0,144			0,744		1,330	0,739	0,119	0,042	1,710			
<u>Kuhlia taeniurus</u>										0,001			
<u>Labotes surinamensis</u>										0,005	0,012		
<u>Epinephelus andersoni</u>						0,015				0,003	0,043		
<u>Sillago sihama</u>										0,003	0,043		
<u>Caranx sexfasciatus</u>						0,053	0,015	0,007	0,024	0,033			
<u>C. ignobilis</u>							0,007						
<u>Trachinotus russellii</u>	0,003												
<u>Scomberoides tala</u>										0,001			
<u>S. commersonianus</u>													
<u>Johnius belengerii</u>										0,018			
<u>Argyrosomus hololepidotus</u>						0,022				0,007	0,006		
<u>Upeneus vittatus</u>										0,005			
<u>Drepane punctata</u>										0,003			
<u>Monodactylus falciformis</u>	0,051				0,063	0,045	0,007	0,021		0,003			
<u>M. argenteus</u>	0,003					0,022				0,025			
<u>Leiognathus equulus</u>	0,045					0,122			0,012	0,286	1,550		
<u>Secutor insidiator</u>										0,025	0,006		
<u>Gerres punctatus</u>						0,015					0,006		
<u>G. rappi</u>	0,066	0,356				0,061		0,007	0,006	0,009	0,049		
<u>G. acinaces</u>								0,003					
<u>Ambassis natalensis</u>	0,147				4,820	0,122				1,680			
<u>A. productus</u>	0,418					1,450		1,080		1,320	2,250		
<u>Lutjanus fulviflamma</u>	0,012	0,020				0,030	0,007	0,003		0,025			
<u>L. argentimaculatus</u>	0,006									0,005			
<u>Pomadasys hasta</u>	0,060					0,122	0,007	0,024		0,168			
<u>P. maculatus</u>										0,001			
<u>P. multimaculatum</u>						0,129		0,014		0,022	0,037		
<u>P. commersoni</u>	0,295			0,093		0,709	0,116	0,049	0,030	0,395	0,093		
<u>Plectorhynchus niger</u>										0,001			
<u>Acanthopagrus berda</u>	0,021					0,015	0,108			0,687			
<u>Rhabdosargus holubi</u>	0,277				0,126	0,839	0,093	0,172	0,030	0,049	0,018		
<u>R. sarba</u>	0,066					0,290		0,007		0,003	0,012		
<u>Diplodus sargus</u>													
<u>Mugil cephalus</u>	0,244			0,868		0,083	6,220	0,070	0,119	2,990			
<u>Valamugil cunnesius</u>	0,226					0,442		0,228	0,335	1,740			
<u>V. buchanani</u>	0,093					0,419	1,150	2,250	0,006	3,110			
<u>Liza dumerili</u>	0,015						0,622	0,330	0,006	0,018			
<u>L. macrolepis</u>	0,009					0,099	0,062	0,098	0,006	1,830			
<u>L. richardsoni</u>					0,126					0,177			
<u>Myxus capensis</u>				0,124			0,070	0,094	0,018	0,001			
<u>Sphyræna jello</u>													
<u>Taenioides jacksoni</u>										0,012			
<u>Psammogobius knysnaensis</u>	0,988					0,358		0,003		0,046	0,062		
<u>Glossogobius giuris</u>	0,750	0,041	0,454	0,031	2,850	0,671	0,070	0,105	0,177	0,373	0,049		
<u>G. biocellatus</u>	0,003					0,038				0,001			
<u>Oligolepis acutipennis</u>	0,515	0,083		0,279		1,980	0,178	0,720		2,960	0,024		
<u>Favonogobius reichei</u>	0,012					0,007				0,003			
<u>F. melanobranchus</u>										0,001			
<u>Caffrogobius natalensis</u>	0,003					0,007				0,059	0,012		
<u>C. multifasciatus</u>													
<u>Croilia mossambica</u>						0,007							
<u>Redigobius dewaali</u>		0,104											
<u>R. bikolanus</u>								0,003					
<u>Periophthalmus sobrinus</u>													
<u>Fleotris fusca</u>	0,039					0,007		0,003		0,022			
<u>Butis butis</u>										0,001			
<u>Pterois volitans</u>	0,006					0,007							
<u>Platycephalus indicus</u>	0,009					0,007				0,016	0,049		
<u>Thyrsoidea macrura</u>	0,003									0,003			
<u>Lactoria cornuta</u>											0,006		
<u>Amblyrhynchotes honckenii</u>										0,003	0,055		
<u>Arothron immaculatus</u>	0,003					0,015				0,029	0,099		
<u>A. hispidus</u>											0,006		
<u>Antennarius striatus</u>						0,007							
<u>A. oligospilos</u>										0,001			

Table 12 (continued)

	Zinkwasi	Ntoni	Mdlotane	Mvoti	Seteni	Mhlali	Tongati	Mdloti	Mhlanga	Mgeni	Turban Fayhead		
FRESHWATER TELEOSTS													
<u>Anquilla bicolor</u>	0,003												
<u>Barbus natalensis</u>				0,093									
<u>B. viviparus</u>				0,155			0,015						
<u>Aplocheilichthys myzopsae</u>							0,132						
<u>Pseudocrenilabrus philander</u>								0,003					
<u>Oreochromis mossambicus</u>	2,390	0,230	0,045	0,899	14,73	0,458	1,59	12,60	0,244	0,040			
<u>Tilapia rendalli</u>							0,007						
<u>Clarias gariepinus</u>				0,062									
<u>Micropterus dolomieu</u>													
MACRURA (prawns)													
<u>Upogebia africana</u>	0,003					0,053				0,140			
<u>Penaeus monodon</u>	0,063					0,030	0,007	0,010	0,006	0,362	0,006		
<u>P. semisulcatus</u>	0,003									0,007	0,031		
<u>P. indicus</u>	0,416					15,60		0,010	0,048	0,918	0,012		
<u>P. canaliculatus</u>	0,027					0,106							
<u>P. japonicus</u>	0,551					0,396		0,010	0,018	0,754	0,303		
<u>Metapenaeus monoceros</u>	0,825	0,020	0,022		0,380	4,220	0,350	0,541	0,079	4,530	0,291		
<u>Parapenaeopsis acclivirostris</u>	0,006												
<u>Caridina typus</u>	0,006	0,020						0,028		0,005			
<u>C. nilotica</u>	0,003			1,080	0,444			0,017		0,046			
<u>Alpheus crassimanus</u>						0,007					0,012		
<u>Macrobrachium equidens</u>	0,117	0,041		5,020		1,070	0,054	0,070		5,290			
<u>M. petersi</u>				0,186									
<u>M. lepidactylus</u>				0,062									
<u>Palaemon concinnus</u>	0,030			4,800	0,444	0,015	0,015	0,630		0,001			
<u>P. pacificus</u>										0,001			
<u>Harpilius depressus</u>										0,009	0,037		
<u>Acetes natalensis</u>	0,051									0,144	0,055		
BRACHYURA (crabs)													
<u>Dehaanius dentatus</u>										0,001			
<u>D. quadridentatus</u>										0,001			
<u>D. scutellatus</u>						0,007							
<u>Hymenosoma orbiculare</u>	0,801					0,068		0,003	0,232	0,088	0,489		
<u>Rhyncoplax bovis</u>	0,578	0,146	0,159		1,580	0,687			0,244				
<u>Macrophthalmus grandidieri</u>						0,007		0,017		0,012			
<u>Tyloidiplax blephariskios</u>	0,003					0,145		0,119		0,451			
<u>Varuna litterata</u>	0,009	0,083		0,124			0,054	0,077	0,012	0,096			
<u>Sesarma catentata</u>							0,287	0,010					
<u>S. eulimene</u>										0,007			
<u>Portunus (Lupa) pelagicus</u>	0,006										0,031		
<u>Monomia gladiator</u>	0,009												
<u>M. argentata</u>										0,001			
<u>Scylla serrata</u>	0,189		0,045		0,253	0,160	0,023	0,038	0,030	0,487	0,024		
<u>Thalamita admete</u>	0,009									0,001	0,006		
<u>Mutata lunaris</u>						0,015	0,007						
<u>Potamonautes sidneyi</u>													
<u>Pilumnus sp.? (xanthid)</u>	0,003												
<u>Calappa hepatica</u>	0,003												
<u>Leucisca squalina</u>										0,001			
<u>Porcellana streptocheles</u>													

Marine fishes: Sipingo - Mzimayi / ...

Table 12 (continued)

MARINE ELASMOBRANCHS and TELEOSTS	Sipingo	Mbokodweni	Manzimtoti	Little Manzimtoti	Lovu	Msimbezi	uMgeababa	Ngene	Mkomazi	Mahlongwana	Mahlongwa	Mpambanyoni	Mzimayi
<u>Dasyatis uarnak</u>									0,013				
<u>Elops machnata</u>													
<u>Megalops cyprinoides</u>													
<u>Gilchristella aestuarius</u>			2,320	0,482	0,720	0,025	1,470		0,052	0,115	0,211		0,689
<u>Stolephorus commersonii</u>									0,008				
<u>Bothus pantherinus</u>					0,016	0,007	0,006		0,032				
<u>Solea bleekeri</u>	0,055		0,109		0,140	0,110	0,026	0,493	3,120	0,046	0,261	0,111	
<u>Paraplaqusia bilineata</u>													
<u>Syngnathus djerong</u>						0,003			0,002				
<u>Fistularia petimba</u>													
<u>Callionymus marleyi</u>													
<u>Terapon jarbua</u>	0,110	0,082	0,032	0,141			0,006		0,079		0,073	0,555	0,045
<u>Kuhlia taeniurus</u>											0,004		
<u>Lobotes surinamensis</u>							0,006		0,022				
<u>Epinephelus andersoni</u>													
<u>Sillago sihama</u>													
<u>Caranx sexfasciatus</u>	0,018			0,028	0,066		0,032	0,054	0,019		0,004		
<u>C. ignobilis</u>													
<u>Trachinotus russellii</u>													
<u>Scomberoides tala</u>													
<u>S. commersonianus</u>									0,002				
<u>Johnius belengerii</u>					0,008				0,046				
<u>Argyrosomus hololepidotus</u>									0,024				
<u>Upeneus vittatus</u>					0,008								
<u>Drepane punctata</u>									0,010				
<u>Monodactylus falciformis</u>						0,029	0,392		0,008		0,004		0,091
<u>M. argenteus</u>	0,147						0,006						
<u>Leiognathus equulus</u>					0,107		0,098		0,052				
<u>Secutor insidiator</u>													
<u>Gerres punctatus</u>													
<u>G. rappi</u>	0,018			0,014	0,033		0,006						
<u>G. acinaces</u>													
<u>Ambassis natalensis</u>						0,121			0,008	0,277	0,118		
<u>A. productus</u>	0,313		0,319	0,567	0,173	0,398	0,137	1,470	0,323	0,046	5,030	0,444	
<u>Lutjanus fulviflamma</u>									0,002				
<u>L. argentimaculatus</u>									0,005				
<u>Pomadasys hasta</u>	0,055	0,041			0,016		0,006		0,032		0,004	0,111	
<u>P. maculatus</u>									0,032				
<u>P. multimaculatum</u>					0,107		0,019		0,022				
<u>P. commersoni</u>			0,013	0,070	0,331		0,052		0,024		0,024		
<u>Plectorhynchus niger</u>					0,008								
<u>Acanthopagrus berda</u>					0,016	0,011			0,076		0,004		
<u>Rhabdosargus holubi</u>	0,110		0,214	0,439	0,049	0,070	0,169	0,054	0,215		0,014		
<u>R. sarba</u>			0,018		0,024	0,025	0,032		0,005				
<u>Diplodus sargus</u>													
<u>Mugil cephalus</u>	0,165	1,310	0,013	0,127	0,008	0,092			0,543		0,004	1,550	0,091
<u>Valamugil cunnesius</u>		0,041				0,003	0,084		0,123		0,187		
<u>V. buchanani</u>		0,041		0,028	0,008	0,007	0,006		0,079			1,920	
<u>Liza dumerili</u>				0,056	0,008	0,003			0,183		0,009		
<u>L. macrolepis</u>	0,288		0,009	0,042	0,008	0,121			0,257		0,083		
<u>L. richardsoni</u>	0,018		0,004										0,183
<u>Myxus capensis</u>				0,297					0,013		0,004		
<u>Sphyraena jello</u>					0,008								
<u>Taenioides jacksoni</u>									0,024				
<u>Psammogobius knysnaensis</u>			0,018			0,007	0,555		0,005				
<u>Glossogobius giuris</u>	0,423		0,251	2,620	0,314	21,00	4,740	1,750	0,329	8,990	4,230		11,40
<u>G. biocellatus</u>													
<u>Oligolepis acutipennis</u>	0,018	0,206	0,013	0,056	1,040	0,048	0,104	0,164	2,830		0,034	0,148	
<u>Favonogobius reichei</u>									0,005				
<u>F. melanobranchus</u>													
<u>Caffrogobius natalensis</u>	0,036					0,008			0,008				
<u>C. multifasciatus</u>													
<u>Croilia mossamica</u>											0,034		
<u>Redigobius dewaali</u>									0,006				
<u>R. bikolanus</u>									0,006				
<u>Periophthalmus sobrinus</u>													
<u>Eleotris fusca</u>	0,018		0,004		0,008		0,013	0,054	0,027		0,004		
<u>Butis butis</u>													
<u>Pterois volitans</u>													
<u>Platycephalus indicus</u>													
<u>Thyrsoidea macrura</u>									0,002				
<u>Lactoria cornuta</u>													
<u>Amblyrhynchotes honckenii</u>													
<u>Arothron immaculatus</u>					0,008	0,003	0,058		0,030				
<u>A. hispidus</u>									0,019				
<u>Antennarius striatus</u>													
<u>A. oligospilos</u>													

Freshwater fishes: Sipingo - Mzimayi / ...

Table 12 (continued)

	Sipingo	Mbokodweni	Manzimtoti	Little Manzimtoti	LOVU	Msimbazi	uMgababa	Ngene	Mkomazi	Mehlongwana	Mahlongwa	Mpanbanyoni	Mzimayi
FRESHWATER TELEOSTS													
<u>Anquilla bicolor</u>													
<u>Barbus natalensis</u>									0,005				
<u>B. viviparus</u>													
<u>Aplocheilichthys myaposa</u>													
<u>Pseudocrenilabrus philander</u>						0,059							0,045
<u>Oreochromis mossambicus</u>	0,847	11,70	3,010	0,397	0,679	8,590	1,670	2,240	0,019	0,670	0,078	1,370	3,216
<u>Tilapia rendalli</u>			0,009										
<u>Clarias gariepinus</u>													
<u>Micropterus dolomieu</u>													
MACRURA (prawns)													
<u>Upogebia africana</u>									0,436				
<u>Penaeus monodon</u>			0,013		0,024	0,033	0,124		0,120		0,019		
<u>P. semisulcatus</u>													
<u>P. indicus</u>	0,036				0,091	0,018	0,830		0,140		0,004		
<u>P. canaliculatus</u>											0,019		
<u>P. japonicus</u>					0,024	0,003	0,013		0,565		0,024		
<u>Metapenaeus monoceros</u>	0,184	0,164	0,205	0,127	0,853	0,040	0,222	0,164	1,000		0,014	0,074	
<u>Parapenaeopsis acclivirostris</u>													
<u>Caridina typus</u>									0,008				
<u>C. nilotica</u>	0,036								0,008		0,014		
<u>Alpheus crassimanus</u>											0,004		
<u>Macrobrachium equidens</u>			0,045	0,014	0,041	0,003	0,104	0,164	9,110		0,118		0,919
<u>M. petersi</u>													
<u>M. lepidectylus</u>													
<u>Palaemon concinnus</u>			0,004	0,014	0,173	0,007	0,104	1,640	7,110		0,019	0,378	
<u>P. pacificus</u>							0,006		0,117				
<u>Harpilius depressus</u>					0,008				0,005		0,004		
<u>Acetes natalensis</u>													
BRACHYURA (crabs)													
<u>Dehaanius dentatus</u>									0,002				
<u>D. quadridentatus</u>									0,019				
<u>D. scutellatus</u>													
<u>Hymenosoma orbiculare</u>	0,165					0,432	0,006		0,134		1,930		
<u>Rhyncoplax bovis</u>	0,903			0,156	0,049	1,910	1,810	0,109	0,008	1,060	3,170	0,074	
<u>Macrophthalmus grandidieri</u>					0,008				0,021				
<u>Tyloidiplax blephariskios</u>					0,016	0,003			0,035				
<u>Veruna litterata</u>		0,123	0,013	0,028		0,016	0,006		0,213		0,044	0,037	0,091
<u>Sesarma catentata</u>	0,055		0,004			0,007							
<u>S. eulimene</u>													
<u>Portunus (Lupa) pelagicus</u>													
<u>Monomia gladiator</u>													
<u>M. argentata</u>													
<u>Scylla serrata</u>	0,202		0,082	0,014	0,041	0,040	0,032	0,657	0,315		0,004	0,037	
<u>Thalamita admete</u>									0,005				
<u>Mutata lunaris</u>													
<u>Potamonautes sidneyi</u>									0,005				
<u>Pilumnus sp.? (xanthid)</u>													
<u>Calappa hepatica</u>													
<u>Leucisca squalina</u>													
<u>Porcellana streptocheles</u>									0,005				

Marine fishes: Mzimba - Mzimba / ...

Table 12 (continued)

MARINE ELASMOBRANCHS and TELEOSTS	Mzinto	Mkumbene	Sezela	Mdesingane	Fafa	Mvuuzi	Mtwelume	Mnamfu	Kwa Makosi	Mfazanana	MhLungwa	Mhlabatshane	Mzombe
<u>Dasyatis varnak</u>													
<u>Elops machnata</u>													
<u>Megalops cyprinoides</u>						0,070							
<u>Gilchristella aestuarius</u>	0,070	0,432		3,510	1,050	0,140	0,153			0,765	0,388		
<u>Stolephorus commersonii</u>													
<u>Bothus pantherinus</u>													
<u>Solea bleekeri</u>	0,017			0,048	0,141		0,230		0,076	0,042	0,083	0,158	0,039
<u>Paraolagusia bilineata</u>													
<u>Syngnathus djarong</u>													
<u>Fistularia petimba</u>													
<u>Callionymus marleyi</u>													
<u>Terapon jarbua</u>		0,054		0,096			0,410						1,020
<u>Kuhlia taeniurus</u>													
<u>Lobotes surinamensis</u>												0,039	
<u>Epinephelus andersoni</u>													
<u>Sillago sihama</u>													
<u>Caranx sexfasciatus</u>													
<u>C. ignobilis</u>													
<u>Trachinotus russellii</u>													
<u>Scomberoides tala</u>													
<u>S. commersonianus</u>													
<u>Johnius belengerii</u>													
<u>Argyrosomus hololepidotus</u>													
<u>Upeneus vittatus</u>													
<u>Drepane punctata</u>													
<u>Monodactylus falciformis</u>				0,048			0,153		0,038		0,027	0,198	0,237
<u>M. argenteus</u>													
<u>Leiognathus equulus</u>							0,051						
<u>Secutor insidiator</u>													
<u>Gerres punctatus</u>													
<u>G. rappi</u>				0,048					0,038	0,042			
<u>G. acinaces</u>													
<u>Ambassis natalensis</u>							0,076		0,038				
<u>A. productus</u>	0,070				0,060	1,540	0,256	0,120		0,085	0,083		0,079
<u>Lutjanus fulviflamma</u>							0,025						
<u>L. argentimaculatus</u>												0,039	
<u>Pomadasys hasta</u>							0,025						
<u>P. maculatus</u>													
<u>P. multimaculatum</u>							0,128						
<u>P. commersonii</u>							0,025						
<u>Plectorhynchus niger</u>													
<u>Acanthopagrus berda</u>													
<u>Rhabdosargus holuhii</u>				0,096	0,121		0,282	0,080					0,158
<u>R. sarba</u>					0,020								
<u>Diplodus sargus</u>													
<u>Muqil cephalus</u>				0,192			0,025						4,230
<u>Valamugil cunnesius</u>							0,179						0,079
<u>V. buchanani</u>				0,530			0,205	0,076					
<u>Liza dumerili</u>				4,190									
<u>L. macrolepis</u>		0,378		0,144			0,717						
<u>L. richardsoni</u>													
<u>Myxus capensis</u>		0,054		0,481			0,128						0,316
<u>Sphyræna jello</u>													
<u>Taenioides jacksoni</u>													
<u>Psammogobius knysnaensis</u>				0,048									0,039
<u>Glossogobius giuris</u>	7,780	0,540		1,730	13,40	3,220	0,128	2,680	0,923	0,510	2,110	1,580	0,039
<u>G. biocellatus</u>													
<u>Oligolepis acutipennis</u>	0,017			0,048			0,538		0,038			0,790	
<u>Favonogobius reichei</u>													
<u>F. melanobranchus</u>													
<u>Caffrogobius natalensis</u>				0,098			0,025						
<u>C. multifasciatus</u>													
<u>Croilia mossambica</u>								0,040	0,076				
<u>Redigobius dewaali</u>													
<u>R. bikolanus</u>													
<u>Periophthalmus sobrinus</u>													
<u>Eleotris fusca</u>							0,076						
<u>Rutis butis</u>													
<u>Pterois volitans</u>													
<u>Platycephalus indicus</u>													
<u>Thyrsoidea macrura</u>													
<u>Lectoria cornuta</u>													
<u>Amblyrhynchotes honckenii</u>				0,048								0,039	
<u>Arothron immaculatus</u>													
<u>A. hispidus</u>													
<u>Antennarius striatus</u>													
<u>A. oligospilos</u>													

Table 12 (continued)

	Mzinto	Mkumbane	Sezela	Mdesingane	Fafa	Mvuzi	Mwalume	Mnamfu	Kwa Makosi	Mfezazana	Mhlangwa	Mhlabatshere	Mzombe
FRESHWATER TELEOSTS													
<u>Anquilla bicolor</u>													
<u>Barbus natalensis</u>													
<u>B. viviparus</u>				0,144									0,198
<u>Aplocheilichthys myaposae</u>						0,842	0,025						0,039
<u>Pseudocrenilabrus philander</u>	0,070	10,50		2,600	3,870	82,00	4,690	0,460	0,923	0,297	0,444	0,079	4,630
<u>Dreochromis mossambicus</u>													
<u>Tilapia rendalli</u>													
<u>Clarias gariepinus</u>													
<u>Micropterus dolomieu</u>													
MACRURA (prawns)													
<u>Upogebia africana</u>							0,051						
<u>Penaeus monodon</u>							0,051						
<u>P. semisulcatus</u>													
<u>P. indicus</u>													
<u>P. canaliculatus</u>													
<u>P. japonicus</u>							0,025						
<u>Metapenaeus monoceros</u>	0,106						0,205		0,038				0,039
<u>Parapenaeopsis acclivirostris</u>													
<u>Caridina typus</u>													
<u>C. nilotica</u>				0,046		0,070							
<u>Alpheus crassimanus</u>													
<u>Macrobrachium equidens</u>				0,096	0,141		1,460	0,120		0,042	0,083		0,435
<u>M. petersi</u>													
<u>M. lepidectylus</u>													
<u>Palaemon concinnus</u>							0,128					0,316	
<u>P. pacificus</u>													
<u>Harpilius depressus</u>													
<u>Acetes natalensis</u>													
BRACHYURA (crabs)													
<u>Dehaanius dentatus</u>													
<u>D. quadridentatus</u>													
<u>D. scutellatus</u>													
<u>Hymenosoma orbiculara</u>												0,039	
<u>Rhyncoplax bovis</u>	0,424			0,144	0,606	5,190				0,042	1,520	0,039	
<u>Macrophthalmus grandidieri</u>													
<u>Tylodiplax blephariskios</u>													
<u>Varuna litterata</u>	0,053	0,054		0,674	0,060			0,040	0,115	0,042			0,356
<u>Sesarma catentata</u>													
<u>S. eulimene</u>													
<u>Portunus (Lupa) pelagicus</u>													
<u>Monomia gladiator</u>													
<u>M. argentata</u>													
<u>Scylla serrata</u>	0,053	0,108					0,205	0,020	0,115	0,127	0,055		
<u>Thalamita admete</u>													
<u>Mutata lunaris</u>													
<u>Potamonautes sidneyi</u>													
<u>Pilumnus sp.? (xanthid)</u>													
<u>Calappa hepatica</u>													
<u>Leucisca squalina</u>													
<u>Porcellana streptocheles</u>													

Marine fishes: iNtshambili - Uvuzana / ...

Table 12 (continued)

MARINE ELASMOBRANCHS and TELEOSTS	iNtshambili	Koshwane	Damba	Mhlangem- kulu	Mtntweni	Mzimkulu	Mbango	Boboyi	Zotsha	Mhlangeni	Vungu	Kongweni	Uvuzana
<u>Dasyatis uarnak</u>													
<u>Elops machnata</u>													
<u>Megalops cyprinoides</u>													
<u>Gilchristella aestuarius</u>	0,326			0,104	0,154	0,132		0,177	0,343	0,062			0,065
<u>Stolephorus commersonii</u>													
<u>Bothus pantherinus</u>													
<u>Solea bleekeri</u>	0,081			0,034	0,022	3,250	0,046	0,044	0,989	0,125	0,090	0,108	
<u>Paraplaqusia bilineata</u>													
<u>Syngnathus djarong</u>													
<u>Fistularia petimba</u>													
<u>Callionymus marleyi</u>													
<u>Terapon jarbua</u>							0,046	0,088		0,156			0,065
<u>Kuhlia taeniurus</u>													
<u>Lobotes surinamensis</u>													
<u>Epinephelus andersoni</u>													
<u>Sillago sihama</u>													
<u>Caranx sexfasciatus</u>													
<u>C. ignobilis</u>													
<u>Trachinotus russellii</u>													
<u>Scomberoides tala</u>													
<u>S. commersonianus</u>													
<u>Johnius belengerii</u>													
<u>Argyrosomus hololepidotus</u>						0,235							
<u>Upeneus vittatus</u>													
<u>Drepane punctata</u>						0,014							
<u>Monodactylus falciformis</u>	0,040	0,045			0,044				0,141				0,262
<u>M. argenteus</u>						0,014							
<u>Leiognathus equulus</u>						0,676							
<u>Secutor insidiator</u>													
<u>Gerres punctatus</u>													
<u>G. rappi</u>	0,040												
<u>G. acinaces</u>													
<u>Ambassis natalensis</u>					0,751	0,279				2,000			
<u>A. productus</u>	0,204	0,091	0,085	0,243	0,441	0,102		0,666	1,550	0,062		0,108	1,110
<u>Lutjanus fulviflamma</u>													
<u>L. argentimaculatus</u>							0,046						
<u>Pomadasyd hasta</u>						0,044							
<u>P. maculatus</u>						0,058							
<u>P. multimaculatum</u>						0,014							
<u>P. commersoni</u>									0,020				
<u>Plectorhynchus niger</u>													
<u>Acanthopagrus berda</u>						0,235			0,020				
<u>Rhabdosargus holubi</u>						0,132		0,088	0,323	0,343			0,459
<u>R. sarba</u>					0,088	0,161	0,093						
<u>Diplodus sargus</u>					0,066								
<u>Muqil cephalus</u>						0,264	0,744	0,622					
<u>Valamugil cunnesius</u>		0,367							0,040				
<u>V. buchanani</u>			0,085			0,235	0,744	0,488	0,101				
<u>Liza dumerili</u>				0,069						0,031			
<u>L. macrolepis</u>		0,045			0,044		0,046	0,044		0,156			
<u>L. richardsoni</u>													0,065
<u>Myxus capensis</u>	0,367											0,216	
<u>Sphyaena jello</u>													
<u>Taenioides jacksoni</u>													
<u>Psammogobius knysnaensis</u>									0,040				
<u>Glossogobius qiurus</u>	1,340	0,183	0,090	4,240	0,397	1,020	0,976	2,000	12,24	0,125	0,090	0,918	39,00
<u>G. biocellatus</u>													
<u>Oligolepis acutipennis</u>					0,132	1,380		0,133	0,060	0,218		0,108	
<u>Favonogobius reichei</u>													
<u>F. melanobranchus</u>													
<u>Caffrogobius natalensis</u>													
<u>C. multifasciatus</u>													
<u>Croilia mossambica</u>					0,044					0,031			
<u>Redigobius dewaali</u>													
<u>R. bikolanus</u>													
<u>Periophthalmus sobrinus</u>													
<u>Eleotris fusca</u>	0,040												
<u>Butis butis</u>													
<u>Pterois volitans</u>													
<u>Platycephalus indicus</u>						0,014							
<u>Thyrsoidea macrura</u>						0,029							
<u>Lactoria cornuta</u>													
<u>Amblyrhynchotes honckenii</u>													
<u>Arothron immaculatus</u>						0,014							
<u>A. hispidus</u>													
<u>Antennarius striatus</u>													
<u>A. oligospilos</u>													

Table 12 (continued)

	iMthambali	Koshwana	Damba	Mhlangam- kulu	Mtintweni	Mzimkulu	Mbango	Boboyi	Zotsha	Mhlangeni	Vungu	Kongweni	Uvuzana
FRESHWATER TELEOSTS													
<u>Anquilla bicolor</u>													
<u>Barbus natalensis</u>													
<u>B. viviparus</u>													
<u>Aplocheilichthys myaposa</u>													
<u>Pseudocrenilabrus philander</u>													
<u>Oreochromis mossambicus</u>	1,300	1,560	9,650	1,000	0,618	0,014	0,837	0,933	0,242	3,620		1,510	0,262
<u>Tilapia rendalli</u>													
<u>Clarias gariepinus</u>													
<u>Micropterus dolomieu</u>									0,020				
MACRURA (prawns)													
<u>Upogebia africana</u>						0,147							
<u>Penaeus monodon</u>						0,014							
<u>P. semisulcatus</u>													
<u>P. indicus</u>													
<u>P. canaliculatus</u>													
<u>P. japonicus</u>						0,029				0,125			
<u>Metapenaeus monoceros</u>					0,044	1,670			0,040	0,062			0,065
<u>Parapenaeopsis acclivirostris</u>													
<u>Caridina typus</u>													
<u>C. nilotica</u>											0,090		
<u>Alpheus crassimanus</u>													
<u>Macrobrachium equidens</u>						5,720			0,222	0,031	0,545		
<u>M. petersi</u>													
<u>M. lepidectylus</u>													
<u>Palaemon concinnus</u>	0,204				0,066				0,626			0,216	
<u>P. pacificus</u>													
<u>Harpilius depressus</u>													
<u>Acetes natalensis</u>													
BRACHYURA (crabs)													
<u>Dehaanius dentatus</u>													
<u>D. quadridentatus</u>						0,014							
<u>D. scutellatus</u>													
<u>Hymenosoma orbiculare</u>													
<u>Rhyncoplex bovis</u>	1,180	0,321		1,110				0,355	0,080			0,462	0,393
<u>Macrophthalmus grandidieri</u>													
<u>Tylodiplax blephariskios</u>						0,191							
<u>Varuna litterata</u>	0,040	0,045		0,139	0,022	0,279	0,046						
<u>Sesarma catentata</u>													
<u>S. eulimene</u>													
<u>Portunus (Lupa) pelagicus</u>													
<u>Monomia gladiator</u>													
<u>M. argentata</u>													
<u>Scylla serrata</u>			0,042		0,022	0,073	0,046		0,080	0,031		0,054	0,196
<u>Thalamita admete</u>													
<u>Mutata lunaris</u>													
<u>Potamonautes sidneyi</u>													
<u>Pilumnus sp.? (xanthid)</u>													
<u>Calappa hepatica</u>													
<u>Leucisca squalina</u>													
<u>Porcellana streptocheles</u>													

Marine fishes: Bilanhlolo - Mtamvuna / ...

Table 12 (continued)

MARINE ELASMOBRANCHS and TELEOSTS	Bilanhlole	Mvutshini	Mbizana	Kaba	Umhlengankulu	Mpenjati	Kandandlovu	Tongazi	Ku Boboyi	Sendundhlu	Zolwane	Mtamvuna	
<u>Dasyatis uarnak</u>													
<u>Elops machnata</u>													
<u>Megalops cyprinoides</u>													
<u>Gilchristella aestuarius</u>		0,219			0,127		0,072		0,297	1,500		0,597	
<u>Stolephorus commersonii</u>													
<u>Bothus pantherinus</u>													0,033
<u>Solea bleekeri</u>	0,444	0,109	0,173	0,067	0,076	0,235	0,144	0,359	0,066	1,150		0,199	
<u>Paraplagusia bilineata</u>													
<u>Syngnathus djarong</u>						0,064							
<u>Fistularia petimba</u>													
<u>Callionymus marleyi</u>													
<u>Terapon jarbua</u>	0,266	0,054	0,546										0,016
<u>Kuhlia taeniurus</u>													
<u>Lobotes surinamensis</u>													
<u>Epinephelus andersoni</u>						0,021							
<u>Sillago sihama</u>													
<u>Caranx sexfasciatus</u>	0,088												
<u>C. ignobilis</u>													
<u>Trachinotus russellii</u>													
<u>Scomberoides tala</u>													
<u>S. commersonianus</u>													
<u>Johnius belengerii</u>													
<u>Argyrosomus hololepidotus</u>													1,490
<u>Upeneus vittatus</u>													
<u>Drepane punctata</u>													
<u>Monodactylus falciformis</u>						0,171			0,033				0,049
<u>M. argenteus</u>							0,216						0,514
<u>Leiognathus equulus</u>													
<u>Secutor insidiator</u>													
<u>Gerres punctatus</u>													
<u>G. rappi</u>			0,024						0,033	0,035			
<u>G. acinaces</u>													
<u>Ambassis natalensis</u>		0,109				0,021							
<u>A. productus</u>	4,220	2,570	0,223	0,100	0,331	0,085	1,180	0,179	2,440	0,526	0,500	0,033	
<u>Lutjanus fulviflamma</u>						0,021				0,070		0,049	
<u>L. argentimaculatus</u>													
<u>Pomadasys hasta</u>									0,033				0,016
<u>P. maculatus</u>													
<u>P. multimaculatum</u>													
<u>P. commersoni</u>	0,266					0,042			0,033	0,280		0,165	
<u>Plectorhynchus niger</u>													
<u>Acanthopagrus berda</u>													0,116
<u>Rhabdosargus holubi</u>	1,280	0,547	0,124			1,450	0,288	0,179	0,297	1,430		11,70	
<u>R. sarba</u>	0,088	0,438				0,085	0,036					0,066	
<u>Diplodus sargus</u>	0,088												
<u>Muqil cephalus</u>	1,110	0,054				0,106				1,010		0,647	
<u>Valamulidunnesius</u>	0,355	0,363											
<u>V. buchani</u>			0,198				0,432	0,269	0,727	0,947			
<u>Liza dumerili</u>						0,021							
<u>L. macrolepis</u>	0,133		0,795										
<u>L. richardsoni</u>	0,088									0,140			
<u>Myxus capensis</u>							0,072						
<u>Sphyræna jello</u>													
<u>Taenioides jacksoni</u>													
<u>Psammodobius knysnaensis</u>										0,175		0,713	
<u>Glossogobius qirus</u>	3,730	14,90	0,273	11,60	5,960	0,641	4,430	0,629	7,140	4,700	0,500	1,470	
<u>G. biocellatus</u>													
<u>Oligolepis acutipennis</u>	0,400	0,054	0,124		0,076	0,106	0,180			0,666		0,116	
<u>Favonogobius reichei</u>													
<u>F. melanobranchus</u>													
<u>Caffrogobius natalensis</u>	0,488		0,298			0,064						0,016	
<u>C. multifasciatus</u>										0,035		0,116	
<u>Croilia mossambica</u>			0,024			0,085				0,070			
<u>Redigobius dewaali</u>													
<u>R. bikolanus</u>													
<u>Periophthalmus sobrinus</u>													
<u>Eleotris fusca</u>													
<u>Butis butis</u>										0,035		0,016	
<u>Pterois volitans</u>													
<u>Platycephalus indicus</u>													0,016
<u>Thyrsoidea macrura</u>										0,035			
<u>Lactoria cornuta</u>													
<u>Amblyrhynchotes honckenii</u>						0,021						0,049	
<u>Arothron immaculatus</u>			0,024	0,033		0,128				0,245		0,298	
<u>A. hispidus</u>													
<u>Antennarius striatus</u>													
<u>A. oligospilos</u>													

Table 12 (continued)

	Bilahlolo	Mvutshini	Mbizana	Kebe	Mhlangan- kulu	Mpenjati	Kandandlovu	Tongazi	Ku Boboyi	Sandlundhlu	Zolwane	Mtamvuna	
FRESHWATER TELEOSTS													
<u>Anguilla bicolor</u>													
<u>Barbus natalensis</u>							0,036						
<u>B. viviparus</u>													
<u>Aplocheilichthys myaposa</u>													
<u>Pseudocrenilabrus philander</u>	1,820	9,090	0,496	0,235	0,229	0,598	3,240		0,363	0,035			
<u>Orsochromis mossambicus</u>		0,054											
<u>Tilapia rendalli</u>													
<u>Clarias gariepinus</u>													
<u>Micropterus dolomieu</u>													
MACRURA (prawns)													
<u>Upogebia africana</u>													
<u>Penaeus monodon</u>												0,016	
<u>P. semisulcatus</u>												1,190	
<u>P. indicus</u>												0,448	
<u>P. canaliculatus</u>												0,979	
<u>P. japonicus</u>													
<u>Metapenaeus monoceros</u>	0,044		0,074	0,033		0,128	0,144			0,385			
<u>Parapenaeopsis acclivirostris</u>													
<u>Caridina typus</u>													
<u>C. nilotica</u>													
<u>Alpheus crassimanus</u>	0,400	0,164					0,648		0,033		2,500	0,016	
<u>Macrobrachium equidens</u>													
<u>M. petersi</u>													
<u>M. lepidactylus</u>	0,088												
<u>Palaeomon concinnus</u>												0,298	
<u>P. pacificus</u>													
<u>Harpilius depressus</u>										0,035		3,310	
<u>Acetes natalensis</u>													
BRACHYURA (crabs)													
<u>Dehaenius dentatus</u>													
<u>D. quadridentatus</u>													
<u>D. scutellatus</u>													
<u>Hymenosoma orbiculare</u>		0,219		1,000	0,764	0,021	0,216	0,099	7,360	0,035		4,780	0,365
<u>Rhyncoplax bovis</u>							0,108						
<u>Macrophthalmus grandidieri</u>													
<u>Tylodiplax blephariskios</u>													
<u>Varuna litterata</u>			0,074		0,025		0,108					0,066	
<u>Sesarma catentata</u>													
<u>S. eulimena</u>													
<u>Portunus (Lupa) pelagicus</u>													
<u>Monomia gladiator</u>													
<u>M. argentata</u>	0,400	0,383	0,198		0,025	0,171	0,036			0,175		0,033	
<u>Scylla serrata</u>													
<u>Thalamita admete</u>													
<u>Mutata lunaris</u>													
<u>Potamonautes sidneyi</u>													
<u>Pilumnus sp.? (xanthid)</u>													
<u>Calappa hepatica</u>													
<u>Leucisca squalina</u>													
<u>Porcellana streptocheles</u>													

END OF TABLE

see also Sub-app.C, in the Appendix). Overall 86 species of fish, 18 species of prawns and 21 species of crabs were caught. 80% of the total catch was accounted for by 13 species. These comprised eight species of fish (Glossogobius giurus, Oreochromis mossambicus, Oligolepis acutipennis, Ambassis productus, Solea bleekeri, Mugil cephalus, Valamugil buchanani and Gilchristella aestuarius), four species of prawns (Macrobrachium equidens, Metapenaeus monoceros, Palaemon concinnus and Penaeus indicus) and a single species of crab (Rhyncoplax bovis).

Numerically, the family Gobiidae (18 209 taken) comprised 32,6% of the ichthyofauna and 22,6% of the overall catch; cichlids (11 820 taken) comprised 21,1% of the ichthyofauna and 14,6% of the overall catch; Mugilidae (9 135 taken) comprised 16,4% of the ichthyofauna and 11,3% overall. Collectively, fishes from these three groups therefore accounted for 70% of the ichthyofauna, and 48,5% of the overall catch.

Amongst the prawns, carids (10 266 taken) represented 52,7% of the prawn catch, and penaeids (8 627 taken) represented 44,3%. Macrobrachium equidens made up 70% of the carid catch and Metapenaeus monoceros 42,4% of the penaeid catch.

Rhyncoplax bovis (2 344 taken) was the most commonly caught crab and represented 45% of all the crabs caught.

Only 12 of the species encountered occurred in more than 30 of the 62 systems studied (Table 13), the most common being Glossogobius giurus, which was found in 59 of them. From the point of view of geographical distribution, detailed information on the occurrence in estuaries of even the common groups such as the Ambassidae, did not previously exist (Martin, pers.comm.). Besides this valuable information on the distribution of several other species such as the common mudbream (Oreochromis mossambicus) (formerly considered not to occur in open systems (Whitfield & Blaber, 1979)) and Croilia mossambica, a burrowing goby formerly considered to be endemic to Maputaland (Blaber & Whitfield, 1977; Bruton & Kok, 1980) was gathered. This study showed that the latter species occurred in at least 11 systems as far south as the Mpenjati (3.56) at latitude 30°57'S. The incidence of penaeid prawns in estuaries, which are species of considerable economic importance to man, had also never been examined in detail along the Natal coastline (de Freitas, 1980).

During the course of the study it became increasingly obvious that

Table 13. Relative abundance of 90 of the species caught by trawl netting in 62 different estuarine localities on the Natal coast during the period September 1979 to November 1982. Those species recorded in only one system have been excluded. These data are derived from Table 16 in Chapter 4

Species	Number of localities	Species	Number of localities
<u>Glossogobius giurus</u>	59	<u>Amblyrhynchotes honckenii</u>	
<u>Oreochromis mossambicus</u>	56	<u>Acetes natalensis</u>	8
<u>Ambassis productus</u>	47	<u>Tylodiplax blephariskios</u>	
<u>Solea bleekeri</u>	46	<u>Monodactylus argenteus</u>	
<u>Scylla serrata</u>		<u>Platycephalus indicus</u>	7
<u>Gilchristella aestuarius</u>	40	<u>Pseudocrenilabrus philander</u>	
<u>Oligolepis acutipennis</u>	38	<u>Argyrosomus hololepidotus</u>	6
<u>Rhyncoplax bovis</u>		<u>Upogebia africana</u>	
<u>Metapenaeus monoceros</u>	37	<u>Syngnathus djarong</u>	
<u>Rhabdosargus holubi</u>	36	<u>Thyrsoidea macrura</u>	
<u>Varuna litterata</u>	33	<u>Caridina typus</u>	5
<u>Macrobrachium equidens</u>	32	<u>Macrophthalmus grandidieri</u>	
<u>Terapon jarbua</u>	30	<u>Alpheus crassimanus</u>	
<u>Mugil cephalus</u>	28	<u>Palaemon pacificus</u>	
<u>Valamugil buehanani</u>	27	<u>Sesarma catentata</u>	
<u>Monodactylus falciformis</u>	24	<u>Thalamita admete</u>	
<u>Liza macrolepis</u>		<u>Favonogobius reichei</u>	4
<u>Palaemon concinnus</u>	23	<u>Barbus viviparus</u>	
<u>Pomadasy s commersonni</u>	21	<u>Lobotes surinamensis</u>	
<u>Rhabdosargus sarba</u>	19	<u>Epinephelus andersoni</u>	
<u>Gerres rappi</u>	18	<u>Lutjanus argentimaculatus</u>	
<u>Pomadasy s hasta</u>		<u>Johnius bel engerii</u>	
<u>Hymenosoma orbiculare</u>	16	<u>Drepane punctata</u>	
<u>Penaeus monodon</u>		<u>Pomadasy s maculatus</u>	
<u>Penaeus japonicus</u>		<u>Glossogobius biocellatus</u>	
<u>Ambassis natalensis</u>		<u>Butis butis</u>	3
<u>Valamugil cunnesius</u>	15	<u>Barbus natalensis</u>	
<u>Myxus capensis</u>		<u>Tilapia rendalli</u>	
<u>Eleotris fusca</u>		<u>Penaeus semisulcatus</u>	
<u>Arothron immaculatus</u>	14	<u>P. canaliculatus</u>	
<u>Psammogobius knysnaensis</u>		<u>Dehaanius quadridentatus</u>	
<u>Caranx sexfasciatus</u>		<u>Elops machnata</u>	
<u>Liza dumerili</u>		<u>Stolephorus commersonii</u>	
<u>Penaeus monodon</u>	13	<u>Sillago sihama</u>	
<u>Caffrogobius natalensis</u>		<u>Secutor insidiator</u>	
<u>Lutjanus fulviflamma</u>		<u>Gerres punctatus</u>	
<u>Acanthopagrus berda</u>	12	<u>G. acinaces</u>	
<u>Leiognathus equulus</u>		<u>Plectorhynchus niger</u>	
<u>Croilia mossambicus</u>	11	<u>Diplodus sargus</u>	2
<u>Bothus pantherinus</u>		<u>Taenioides jacksoni</u>	
<u>Caridina nilotica</u>	10	<u>Caffrogobius multifasciatus</u>	
<u>Pomadasy s multimaculatum</u>	9	<u>Redigobius dawaali</u>	
<u>Liza richardsoni</u>		<u>Pterois volitans</u>	
		<u>Harpilius depressus</u>	
		<u>Dehaanius dentatus</u>	
		<u>Portunus pelagicus</u>	
		<u>Mutata lunaris</u>	

by virtue of their abundance certain species were more common in closed systems than they were in open (Table 14), whilst others were more numerous in open systems than they were in closed. Because of this the terms 'lagoon-associated' and 'estuary-associated' have been adopted in the text of the Appendix. The reason seemed attributable to the differing degree of contact with the sea because in open systems the larvae and juveniles of numerous marine species are transported into the system at high tide. Although the same thing can happen in closed systems whenever they are open, or by topping of the bar, the impression gained was that most life within such systems has become adapted to the static conditions which prevail. The most important adaptation of all is the need to complete their life cycle within the system in question and thereby become independent of direct contact with the sea. In terms of numerical abundance, the proportion of these species generally overwhelmed the catch. With few exceptions the data presented in Table 14 show that systems which are normally closed are commonly dominated by four particular species (G. aestuarius, G. giurus, O. mossambicus and R. bovis), whereas in systems that are normally open their relative abundance drops unless mouth closure regularly occurs (for instance in the Lovu, Mpambanyoni and Mtwalume) or the system is perched above sea level (e.g. Boboyi) or kept open artificially as in the Mhlabatshane (3.36). In each case the community composition alters accordingly (see also Fig.23 Chap.4).

For essentially similar reasons (i.e. the prevailing mouth condition), a vast difference in species diversity was discernible between each of the 62 estuaries studied. Although an impoverished fauna is a widely recognized characteristic of closed systems (Grindley,1980; Hodgkin,1980; Day,1981) and regions in which the salinity is reduced to 5‰ - 7‰ (Remane & Schlieper,1971) no attempt has yet been made in South Africa to compare the relative species richness of a set of estuaries along a substantial stretch of coastline, in this case measuring 240 km. Amongst the differences observed (Fig. 7), mouth condition was obviously not the only operative environmental determinant. For example in the Sezela (3.27), pollution played a role in accounting for the total absence of life in the system. Pollution also suppressed species richness in systems such as the Tongati, Sipingo and Mbokodweni. In other estuaries salinity seemed to be an influential factor, and especially

Table 14. The comparative proportions of four commonly encountered species (expressed as a percentage of the total catch) in closed systems (a) as opposed to open systems (b). The Vungu (3.48) and Zolwane (3.61) have been excluded as both were untrawlable.

(a)

	Code N°	Gilchristella	Glossogobius	Oreochromis	Rhyncoplax	% Total catch
		aestuarius	giurus	mossambicus	bovis	
Zinkwasi	3. 1	15,99	5,66	18,06	4,37	44,08
Nonoti	3. 2	23,94	2,82	15,49	9,86	52,11
Mdlotane	3. 3	15,79	52,63	5,26	18,42	92,10
Seteni	3. 5	5,79	10,42	53,70	5,79	75,70
Mdloti	3. 8	1,64	0,54	64,98	-	67,16
Mhlanga	3. 9	4,41	9,83	13,56	13,56	41,36
Sipingo	3.12	-	10,75	21,50	22,90	55,15
Mbookodweni	3.13	-	-	83,53	-	83,53
Manzimtoti	3.14	34,32	3,70	44,48	-	82,50
Little Manzimtoti	3.15	8,42	45,79	6,93	2,72	63,86
Msimbazi	3.17	0,08	63,15	25,81	3,75	92,79
uMgababa	3.18	11,31	36,50	12,87	13,93	74,61
Ngane	3.19	-	19,39	24,85	1,21	45,45
Mahlongwana	3.21	1,03	80,21	5,98	9,48	96,70
Mahlongwa	3.22	1,32	26,38	0,49	19,81	48,00
Mzimayi	3.24	4,11	67,95	19,18	-	91,24
Mzinto	3.25	0,82	89,80	0,82	4,90	96,34
Mkumbane	3.26	3,54	4,42	86,73	-	94,69
Sezela	3.27	-	-	-	-	-
Mdesingane	3.28	23,32	11,50	17,25	0,96	53,03
Fafa	3.29	5,38	68,84	19,88	3,11	97,21
Mvuzi	3.30	0,15	3,47	88,09	5,58	97,29
Mnamfu	3.32	-	73,63	13,19	-	86,82
Kwa Makosi	3.33	-	36,92	36,92	-	73,84
Mfazazana	3.34	38,30	25,53	14,89	2,13	80,85
Mhlungwa	3.35	8,09	43,93	9,25	31,79	93,06
iNtshambili	3.38	6,30	25,98	25,20	22,83	80,31
Koshwana	3.39	-	6,90	58,62	12,07	77,59
Damba	3.40	-	52,56	46,42	-	98,98
Mhlangankulu	3.41	1,50	61,00	14,50	16,00	93,00
Mtentweni	3.42	5,22	13,43	20,90	-	39,55
Mbango	3.44	-	26,58	22,78	-	49,36
Zotsha	3.46	1,88	66,89	1,32	6,07	76,16
Mhlangeni	3.47	0,87	1,74	50,43	-	53,04
Kongweni	3.49	-	26,98	44,44	4,76	76,18
Uvuzana	3.50	0,16	92,97	0,63	0,94	94,70
Bilahlolo	3.51	-	23,60	11,52	-	35,12
Mvutshini	3.52	0,74	50,84	30,91	0,74	83,23
Mbizana	3.53	-	7,43	13,51	-	20,94
Kaba	3.54	-	88,78	1,79	7,65	98,22
Umhlangankulu	3.55	1,67	78,26	3,01	10,03	92,97
Mpenjati	3.56	-	14,02	13,08	-	27,10
Kandandlovu	3.57	0,62	38,20	27,95	1,86	68,63
Ku-Boboyi	3.59	2,56	61,54	3,13	0,85	68,08
AVERAGE						72,37

Table 14 continued

(b)

	Code N°	<u>Gilchristella</u>	<u>Glossogobius</u>	<u>Oreochromis</u>	<u>Rhyncoplax</u>	% Total catch
		<u>aestuaris</u>	<u>giurus</u>	<u>mossambicus</u>	<u>bovis</u>	
Mvoti	3. 4	0,84	0,21	6,09	-	7,14
Mhlali	3. 6	1,52	1,91	1,30	1,95	6,68
Tongati	3. 7	-	0,58	13,18	-	13,76
Mgeni	3.10	0,08	1,03	0,11	-	1,22
Durban Bayhead	3.11	-	0,82	-	-	0,82
Lovu	3.16	13,68	5,97	12,89	0,94	33,48
Mkomazi	3.20	0,19	1,17	0,07	0,03	1,46
Mpambanyoni	3.23	-	-	20,33	1,10	21,43
Mtwalume	3.31	1,44	1,20	43,88	-	45,44
Mhlabatshane	3.36	-	57,14	2,86	1,43	61,43
Mzumbe	3.37	-	0,33	39,74	-	40,07
Mzimkulu	3.43	0,80	6,23	0,09	-	7,12
Boboyi	3.45	3,15	35,43	16,54	6,30	61,42
Tongazi	3.58	-	38,89	-	-	38,89
Sandlundlu	3.60	7,14	22,26	0,17	0,17	29,74
Mtamvuna	3.62	1,99	4,91	-	1,21	8,11
AVERAGE						23,64

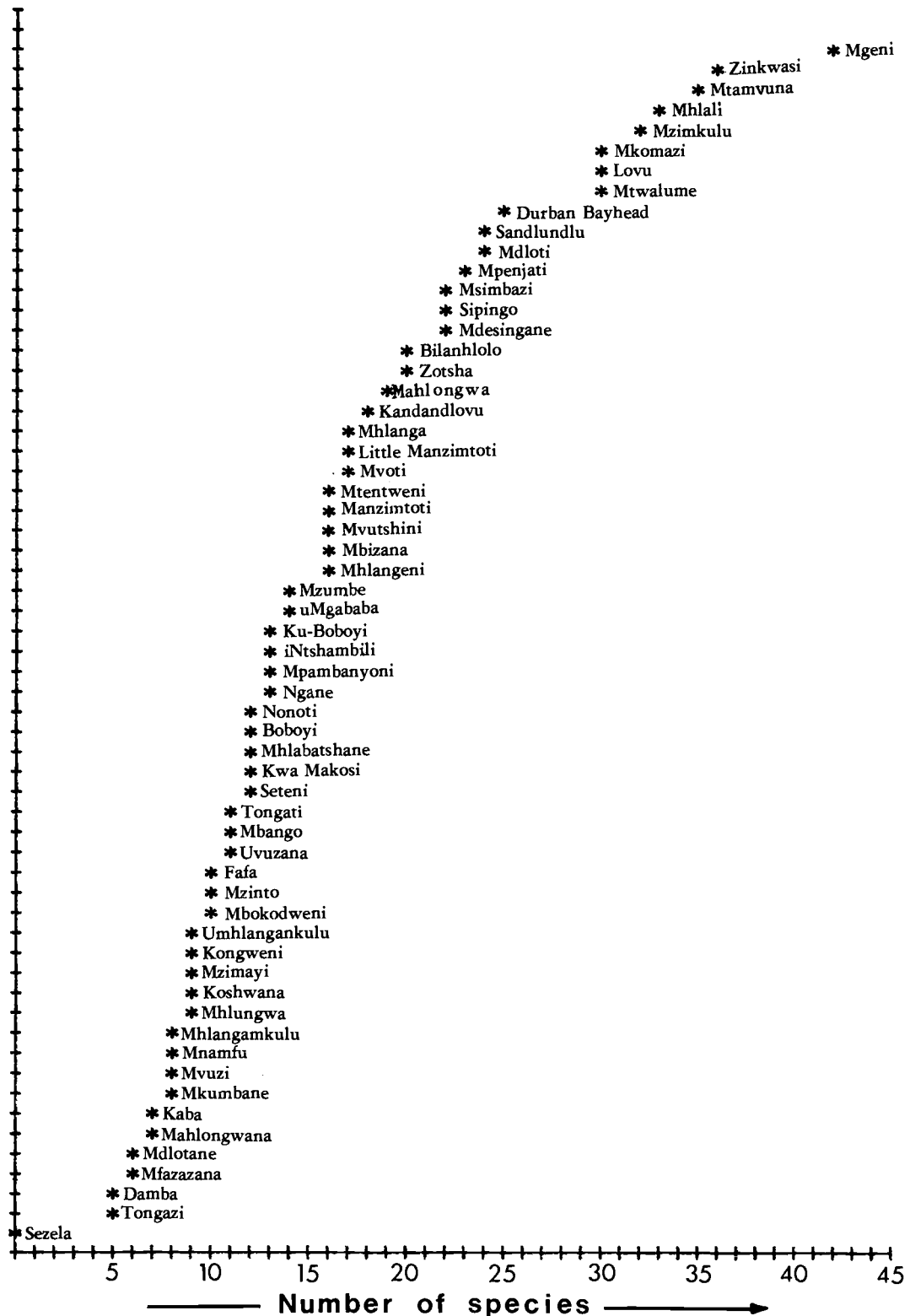

Fig.7 The relative species richness of 60 systems south of the Tugela River in Natal. To equate the relative effort expended trawl netting in each system, the total number of fish, prawn and crab species caught after three visits to each system are shown. The Vungu and Zolwane have been dropped because neither could be effectively sampled by trawling (see Appendix).

where substantial increases occurred. The most striking example perhaps is the Zinkwasi which, albeit closed for 80% of the year, is sufficiently saline (21‰) to maintain a wide variety of species that are more normally found in open, tidally influenced systems.

Another possible determinant in the trend depicted by Figure 7 is nutrient availability. The discharge of sewage effluent into the Mgeni and the Zinkwasi could enhance biological utilization, although in the case of the Mgeni, the most species rich of any of the estuaries studied, the open mouth, salinity regime and silty bottom materials are far more important environmental factors. Another factor which needs to be taken into consideration is artificial breaching of the mouth, as occurs in the Mloti. Although regarded as being environmentally damaging (Howard-Williams and Allanson, 1979; Whitfield, 1980; Blaber *et al.*, 1982) breaching does enhance species richness of such a system by improving contact with the sea. In the Mpenjati, which is periodically opened by bulldozer to facilitate the removal of sand from the estuary basin, species richness is similarly affected.

Conclusions

Amongst the estuaries in the study area enormous variation occurs in terms of both their abiotic and biotic nature as well as man-induced perturbation. For both the short and long term needs of planning and management to be catered for, a classification of this resource is desirable as a basis for distinguishing between specified types of estuaries. A classification of the type envisaged would also serve as a means of:

- * selecting areas for conservation;
- * designating usage (potential utilities and disutilities);
- * planning development;
- * planning research;
- * predicting the responses of certain estuary types to given forms of development;
- * predicting the resilience of each estuary type;
- * providing uniformity in concepts and terminology in Natal;
- * monitoring the condition of each estuary hereafter, and
- * improving the value judgements presently being made of these resources.

The next chapter is designed, amongst other things, to provide the basis of such a classification.

CHAPTER FOUR

ESTUARY CLASSIFICATION

4.1 Introduction

Since the turn of the century numerous attempts have been made to classify habitats throughout the world (Goodall,1953; Whittaker,1962) because the grouping of objects on the basis of their similarities has always been part of the 'thinking process' in man (Morant,1981). Despite this, the classification of estuaries is a confusing and controversial subject that has vexed the scientific community for many years (Segestråle, 1959; Caspers,1967) largely due to of the infinite variety of environmental factors that determine the characteristics of estuarine environments in general. This has not only created confusion amongst the scientific community (Reddering 1980) but also amongst people in other professions such as engineers, planners and policy-makers who have no firsthand knowledge of the subject, but nevertheless are intimately involved in coastal zone management.

Some of the earliest attempts to classify estuaries were made by geographers (Johnson,1919; Finch et al.,1957) on the grounds that differences were discernible between estuaries in terms of their geomorphological origin and form. For a long time salinity was used, as a distinguishing factor, and still is (Redeke,1922; Välikangas, 1926; Dahl,1956; Remane & Schlieper,1971). In addition, salinity plus modifying factors such as hydrology and climate (Rochford,1951) have also been used. Subsequent approaches involved salt balance equations (Pritchard,1967) and differentiation between the dominant physical processes associated with circulation and mixing (Hansen & Rattray, 1966; Bowden,1967). As a common denominator measuring processes of several kinds, energy flow was used to good effect as a basis for differentiating between estuaries in the United States by Odum and Copeland (1969). More recently 'biotic provinces' along the coastline based on differences in sea temperatures, tidal range, wave energy, climate and coastal geology have been used (Day,1981). In the process, an astonishing variety of definitions and terms (such as 'thalassohaline' (Bond,1935) as a specific type of brackish water, and 'hyphalmyrobients' (Remane & Schlieper,1971) as a group of organisms associated with a particular salinity range) have materialized.

It is not intended to review the validity of these terms, nor to discuss the multitude of definitions that have been proposed. However, it seems clear that a problem area in estuary classification using environmental variables is the fact that because of the dynamism of estuaries (Day, 1951; Hedgpeth, 1957; Jennings & Bird, 1967) consensus has never been reached regarding which environmental variables are the most relevant for the purpose of deriving an all-encompassing definition of the term 'estuary'. Despite this, the internationally accepted definition of an estuary today is "...a semi-enclosed coastal body of water which has free connection with the open sea and within which sea water is measurably diluted with fresh water from land drainage." (Cameron & Pritchard, 1963). Another school of thought maintains there are such things as closed estuaries, which implies that free connection with the sea is not essential (Day, 1980; 1981).

On reflection of the logic expressed by several authors such as Goodall (1954); Day (1967); Odum and Copeland (1969); Day et al. (1971); Gosselink and Turner (1978); and Gladson (1981) all of whom have pointed out that the biota associated with any particular ecosystem synthesize whatever environmental variables are involved into one common response, it seemed clear that the "red-herring" in estuary classification has been man's preoccupation with the classification of environmental variables instead of the biota.

For example, in wetland ecosystems the variation in certain hydrological relationships produced soil types of different forms, and these in turn determine the character of the vegetation. As the end product of the environmental variables imposed upon that ecosystem, the vegetation becomes a useful index for the identification and classification of wetlands. This reflects the thinking of Goodall (1954) who emphasized that "... complexes of environmental factors determining plant distribution can be indicated and measured better indirectly, through the plants themselves, than by direct physical measurements ...".

Certain authors (den Hartog, 1960; Caspers, 1967) discuss the benefits that could be derived from "biological analysis" as a means of differentiating between estuaries, but to date no concerted effort has been made to put these ideas into practice. An investigation into community composition therefore seemed to be a potential key to the classification of Natal's estuaries (Fig. 8), as well as a means of

Fig. 8. The conceptual basis of a classification strategy for Natal's estuaries (adapted from Gosselink and Turner, 1978 and Breen, 1982).

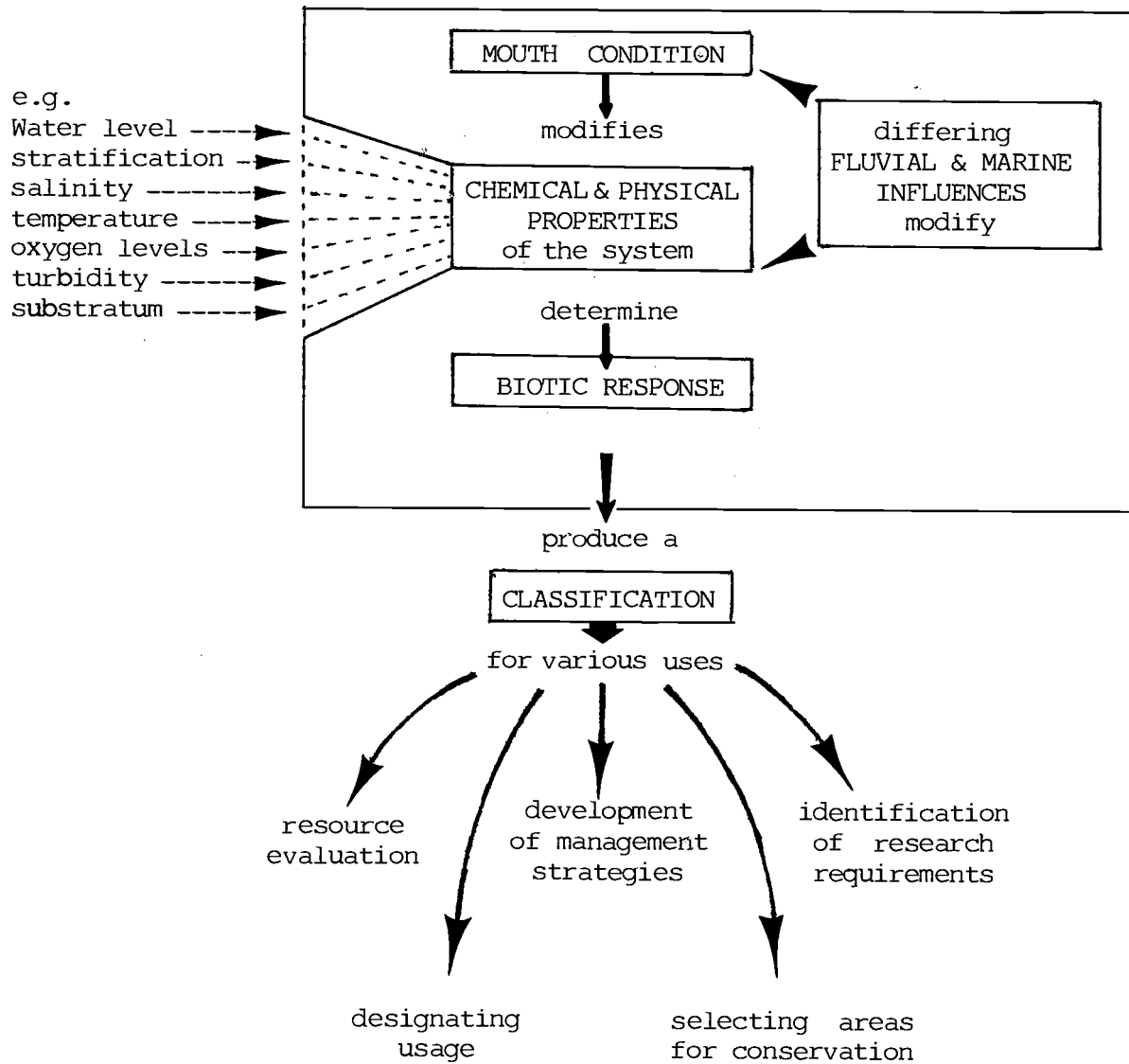

determining whether systems with free connection to the open sea (as defined by Cameron and Pritchard, 1963) were discernibly different from systems with intermittent connection with the sea (as suggested by Barnes, 1980). In essence, the prospect of using the biota as synthesizers of whatever variables were involved in the wide variety of estuaries described in Chapter 3, seemed to have considerable merit. An added reason for adopting this approach was because with the aid of computers community classification has become steadily perfected in recent years (Whittaker, 1967) particularly by botanists involved in the classification of plant communities (Bray & Curtis, 1957; Moore et al., 1970; Huntley & Birks, 1979). It has also become clear that the impracticality of processing large data sets can be overcome by using a computer, as well as the subjectivity inherent in many classifications.

The value of multivariate analysis in the classification of marine communities has been demonstrated by several workers (Cassie, 1967; Field & McFarlane, 1968; Buzas, 1970; Field & Robb, 1970; Boesch, 1973; McCall, 1978; Rainer & Fitzhardinge, 1981) but to date no attempt, other than that by Siegfried (1981b), has been made to use community data for the purpose of estuary classification. This may be due to the inherently high level of variability at population and community levels in estuaries (Livingston, 1979), or a result of their biological instability. However, the need for such an approach was foreseen and adopted by Siegfried (1978, 1981b) despite the fact that he realized at the time that a major problem was the unavailability of the required data. Siegfried attempted to use the avifauna as a means of classifying a variety of estuaries along 3000 km of the South African coastline (between the borders of South West Africa and Mozambique) but was limited by the inadequacy of the data themselves which had been collected by a variety of fieldworkers for completely different purposes. As a result some strange associations were formed by cluster analysis, which bear little resemblance to those achieved in the present study.

As outlined in Chapter 1, this study was specifically undertaken to obtain the data considered relevant for classification purposes, and in terms of the objectives of the study (Chap 1), to use these data as a means of producing a classification of Natal's estuaries; as a means of defining their current and future environmental

condition, and as a means of gaining further insight into the present day biological utilization of these systems. Throughout, the assumption made was that the biota present in any of the 62 systems studied would synthesize whatever environmental variables were involved into one common response. Furthermore, with the aid of multivariate analysis, the results could be tested and refined in order to obtain a deeper insight into the community structure and dynamics of each system.

4.2 METHODS

4.2.1 Provisional classification

In the knowledge that not all 62 systems in the study area complied with the definition of an estuary (sensu Cameron and Pritchard, 1963) (Chap. 3), the decision was made to differentiate between them using the two key criteria that are embodied in their definition (namely, free connection with the open sea (which is tantamount to saying the system is tidal) and the measurable dilution of seawater by freshwater). These, together with tidal exchange were used in the following way:

- a) If the system was tidal, freely connected to the sea, and comprised of seawater measurably diluted by freshwater, the system was regarded, by definition, as an estuary.
- b) If the system was tidal, freely connected to the sea but contained seawater undiluted by freshwater, the system was regarded as a bay.
- c) If the system was atidal, and separated from the sea but contained seawater measurably diluted by freshwater, the system was regarded as a lagoon (following the views expressed by Barnes, 1980).
- d) If the system was outwardly open to the sea but atidal (by virtue of its elevation above sea level), and totally fresh it was regarded as a river mouth.

These distinctions are synthesized in Table 15.

Table 15. A provisional basis for the classification of "estuaries" in Natal using the criteria contained in the definition of an estuary provided by Cameron & Pritchard (1963), plus tidal exchange.

Environmental variable				
Free connection with the open sea	+	+	-	+
Seawater measurably diluted with freshwater	+	-	+	-
Tidal exchange	+	+	-	-
Classification	Estuary	Bay	Lagoon	River Mouth

4.2.2 Ordination

A geometric concept fundamental to an understanding of ordination is that of species space and samples space because the sample-by-species matrix in which most ecological data are presented (Table 16) can be visualized in a multidimensional form.

If spatially represented (Fig.9) species and samples spaces differ only in that species represent the axes in samples space, and samples represent the axes in species space. In the context of the present study, however, in which the data matrices comprised 125 species and up to 59 samples, the number of dimensions involved are impossible to visualize. Detrended correspondence analysis (or DECORANA) was developed by Hill (1979b) in an endeavour to reduce high-dimensional data of this nature onto a graph of two dimensions, and so enable the distribution of the sample points to be inspected (Gauch,1982). Very little information is sacrificed in the process and both communication and comprehension of the data are effected.

The result of such an analysis is a scatter diagram or graph which enables relationships between samples to be visualized. The samples (or species) are grouped in such a way that similar entities are near each other and dissimilar entities are far apart. Despite this, ordination remains as an exploratory technique designed to reveal little else but the underlying structure of the data set (Goodman, pers.comm.).

For the sake of comparison, the data contained in Table 12 (Chap.3) were also used for the purpose of ordination. These data represent abundance values created by expressing the raw data (Sub-app C, in the Appendix) in terms of catch per unit of effort (CPUE). As is customary log transformation (using \log_e) was required to scale down the weight of the most abundant species to prevent these from swamping the other data (Field et al.,1982).

4.2.3.Cluster analysis

Cluster analysis is generally the first step in community analysis (Field et al.,1982) and is used to identify broad inter-group relationships in the data set. Numerous techniques are available, each of which differs greatly according to their relative emphases on a variety of division criteria (Gauch,1982), but in general terms clustering is performed by searching through the

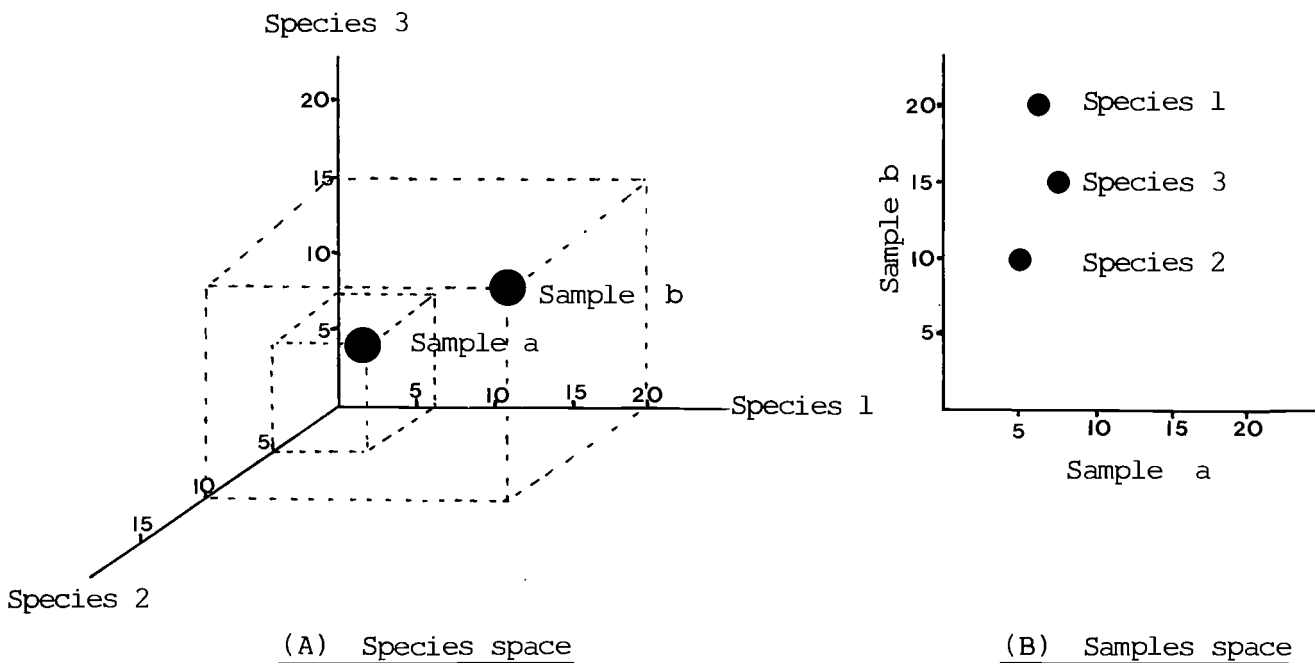

Fig.9 Spatial relationships between two samples and three species in species space (A) and samples space (B). Sample a has abundances of 6,5 and 7,5 for species 1-3 respectively; and sample b has abundances of 20,10 and 15 for species 1-3 respectively. Both A & B contain the identical information but expressed in different ways. (A) is after van Groenewoud (1965); and (B) after Gauch (1982). "Samples with similar species occupy nearby positions in species space, whereas species with similar distributions in the sample set (for example 1 & 3) occupy nearby positions in samples space" (Gauch,1982).

sample by species matrix (for example Table 16) and linking those samples that are most alike in terms of species composition. The result of such an analysis is a dendrogram indicating the hierarchical similarity structure of the data.

Two techniques were tested, including a method developed by Field and McFarlane (1968) using the Bray-Curtis measure of similarity (Bray & Curtis, 1957) and the group-average sorting method (after Lance & Williams, 1967); and a program developed by Hill (1969a) called two-way indicator species analysis (or "TWINSPAN") wherein corresponding sample and species hierarchical classifications are produced. Neither proved to be particularly effective as the data did not lend themselves to being forced into discrete classes by hierarchical clustering. This tended to suggest that community variation in the systems studied was semi-continuous because of subtle differences between variables such as mouth condition and salinity .

As detrended correspondence analysis (Sect.4.2.2) was found to be an especially robust and effective ordination technique, as confirmed by Wilson (1981), "ordination space partitioning" (after Noy-Meir, 1973; Hall & Swain, 1976) was used as a simple, polythetic clustering technique.

Put simply, ordination space partitioning means that sample groups were defined subjectively by drawing partitions (or boundaries) in the ordination graphs to generate a divisive, hierarchical classification. The method is also recommended by Williams (1971) in cases where field experience has provided a general understanding of the data that cannot be supplied or specified precisely to the computer.

4.2.4 Gradient analysis

The method adopted to ascertain the part played by various environmental factors in the sample and species ordinations, was that recommended by Field et al. (1982) and Gauch (1982) where the environmental factors considered influential are independently superimposed over the ordination

Sample groups were first defined by ordination space partitioning and then transferred to the ordination. Scaled symbols were used to create a visual impression of the major differences between the sample groups. This was achieved by superimposing the variables listed in

Table 17 one at a time over the ordination.

Information statistics such as analysis of variance or multiple discriminant analysis (Green & Vascotto, 1978) were not used to determine the relative importance of each environmental variable, as the differences revealed by the above method were obvious enough to make it unnecessary. Furthermore, certain of the variables involved (Table 17) were not measured.

4.3 RESULTS

4.3.1 Provisional classification

By allocating each of the systems studied to one or other of the four categories proposed in Table 15, the following groups, ranked in geographical order from north to south, were achieved:

BAY	Durban Bayhead
ESTUARY	Mhlali, Tongati, Mgeni, Lovu, Mkomazi, Mpambanyoni, Mtwalume, Mhlabatshane, Mzumbe, Mzinkulu, Boboyi, Tongazi, Sandlundlu, Mtamvuna
LAGOON	Zinkwasi, Nonoti, Mdlotane, Seteni, Mdloti, Mhlanga, Sipingo, Mbokodweni, Manzimtoti, Little Manzimtoti, Msimbazi, uMgababa, Ngane, Mahlongwana, Mahlongwa, Mzimayi, Mzinto, Mkumbane, Mdesingane, Fafa, Mvuzi, Mnamfu, KwaMakosi, Mfazazana, Mhlungwa, iNtshambili, Koshwana, Damba, Mhlangankulu, Mtentweni, Mbango, Zotsha, Mhlangeni, Kongweni, Uvuzana, Bilanhlolo, Mvutshini, Mbizana, Kaba, Umhlangankulu, Mpenjati, Kandandlovu, Ku-boboyi
RIVER- MOUTH	Mvoti

The validity of these groupings were then tested using multivariate analysis, in the belief that they would be reflected by the biota present. It also seemed likely that a continuum of variation occurred between systems identifiable as a rivermouth for example and, at the opposite end of the scale, systems identifiable as a marine bay. In between these two extremes lay a variety of different estuaries and lagoons. An added advantage of this approach was that ordination was likely to provide a means of effectively communicating these results and to reveal certain inter-relationships between systems that may otherwise have been difficult to detect.

Three systems in the study area were excluded from the analysis, these being the Sezela (as completely lifeless) and the Vungu and Zolwane (as untrawlable propositions).

4.3.2 Ordination and clustering

Decorana (DCA) was used to produce an ordination of the data in Table 16. The sample ordinations generated are shown in two (Fig. 10) and three (Fig. 11) dimensions. The resultant species ordinations of fishes (Fig. 12) and prawns and crabs (Fig. 13) were separated to avoid clutter. Ordination space partitioning (Fig. 14) was used to generate groups within the sample ordination (Fig. 10).

DCA was also used to produce an ordination of the data in Table 12 (Fig.15) to compare this result with that achieved by ordination of the data in Table 16 (Fig.10). Because of the importance of Figures 10,12,13 and 14 to the ensuing discussion, these particular figures are separately available as "pull-outs" at the back of this thesis, to facilitate reference.

In the initial interpretation of the above results, the relationship of the sample groups in Figure 14 to each of the environmental variables in Table 17 will be examined. All of the subsequent figures (16-22) are therefore aimed at showing whether the variables selected had common, related or opposing distributions within the key ordination (Fig.10).

Table 16 (continued)

Mtambvuna	*	
Zolwane ◀		
Sandlundlu	*	
Ku-Boboyi	*	
Tongazi	*	
Kandandlovu	*	
Mpenjati	*	
Umhlangankulu	*	
Kaba	*	
Mbizana	*	
Mvutshini	*	
Bilanhlole	*	
Uvuzana	*	
Kongweni	*	
Vungu ◀	*	
Mhlangeni	*	
Zotsha	*	
Boboyi	*	
Mbango	*	
Mzimkulu	*	
Mtentweni	*	
Mhlangankulu	*	
Damba	*	
Koshwana	*	
iNtshambili	*	
Mzumbe	*	
Mhlabatshane	*	
Mhlungwa	*	
Mfazazana	*	
Kwa Makosi	*	
Mnamfu	*	
Mtwalume	*	
Mvuzi	*	
Fafa	*	
Mdesingane	*	
Sezela ◀	*	
Mkumbane	*	
Mzinto	*	
Mzimayi	*	
Mpambanyoni	*	
Mahlongwa	*	
Mahlongwana	*	
Mkomazi	*	
Ngane	*	
uMgababa	*	
Msimbazi	*	
Lovu	*	
Little Manzimtoti	*	
Manzimtoti	*	
Mbokodweni	*	
Sipingo	*	
Durban Bayhead	*	
Mgeni	*	
Mhlanga	*	
Mdloti	*	
Tongati	*	
Mhlali	*	
Seteni	*	
Mvoti	*	
Mdlotane	*	
Nonoti	*	
Zinkwasi	*	
<i>Mugil cephalus</i>		
<i>Valemugil cunnesius</i>		
<i>V. buchanani</i>		
<i>Liza dumerili</i>		
<i>L. macrolepis</i>		
<i>L. richardsoni</i>		
<i>Myxus capensis</i>		
<i>Sphyræna jello</i>		
<i>Taenioides jacksoni</i>		
<i>Psammodobius knysnaensis</i>		
<i>Glossogobius giuris</i>		
<i>G. biocellatus</i>		
<i>Oligolepis acutipennis</i>		
<i>Favonogobius reichei</i>		
<i>F. melanobranchus</i>		
<i>Caffrogobius natalensis</i>		
<i>C. multifasciatus</i>		
<i>Croilia mossambica</i>		
<i>Redigobius dewaali</i>		
<i>R. bikolanus</i>		
<i>Peripthalmus sobrinus</i>		
<i>Eleotris fusca</i>		
<i>Butis butis</i>		
<i>Pterois volitans</i>		
<i>Plectrocephalus indicus</i>		
<i>Thyrsoidea macrura</i>		
<i>Lactoria cornuta</i>		
<i>Amblyrhynchotes honckenii</i>		
<i>Arothron immaculatus</i>		
<i>A. hispidus</i>		
<i>Antennarius striatus</i>		
<i>A. oligospilus</i>		
FRESHWATER FISHES		
<i>Anquilla bicolor</i>		
<i>Barbus natalensis</i>		
<i>B. viviparus</i>		
<i>Aplocheilichthys mveposae</i>		
<i>Pseudocrenilabrus philander</i>		
<i>Oreochromis mossambicus</i>		
<i>Lilapia rendalli</i>		
<i>Clarias gariepinus</i>		
<i>Micropterus dolomieu</i>		

Fig.10 The ordination of 59 systems in Natal by detrended correspondence analysis, using the presence or absence data contained in Table 16. Axis 1 distinguishes closed systems from open systems. Based on the categorization of the above systems in Section 4.3.1, they are differentiated in the following way:

- ☆ ... river mouths
- ... lagoons
- ... estuaries
- ⊙ ... bays

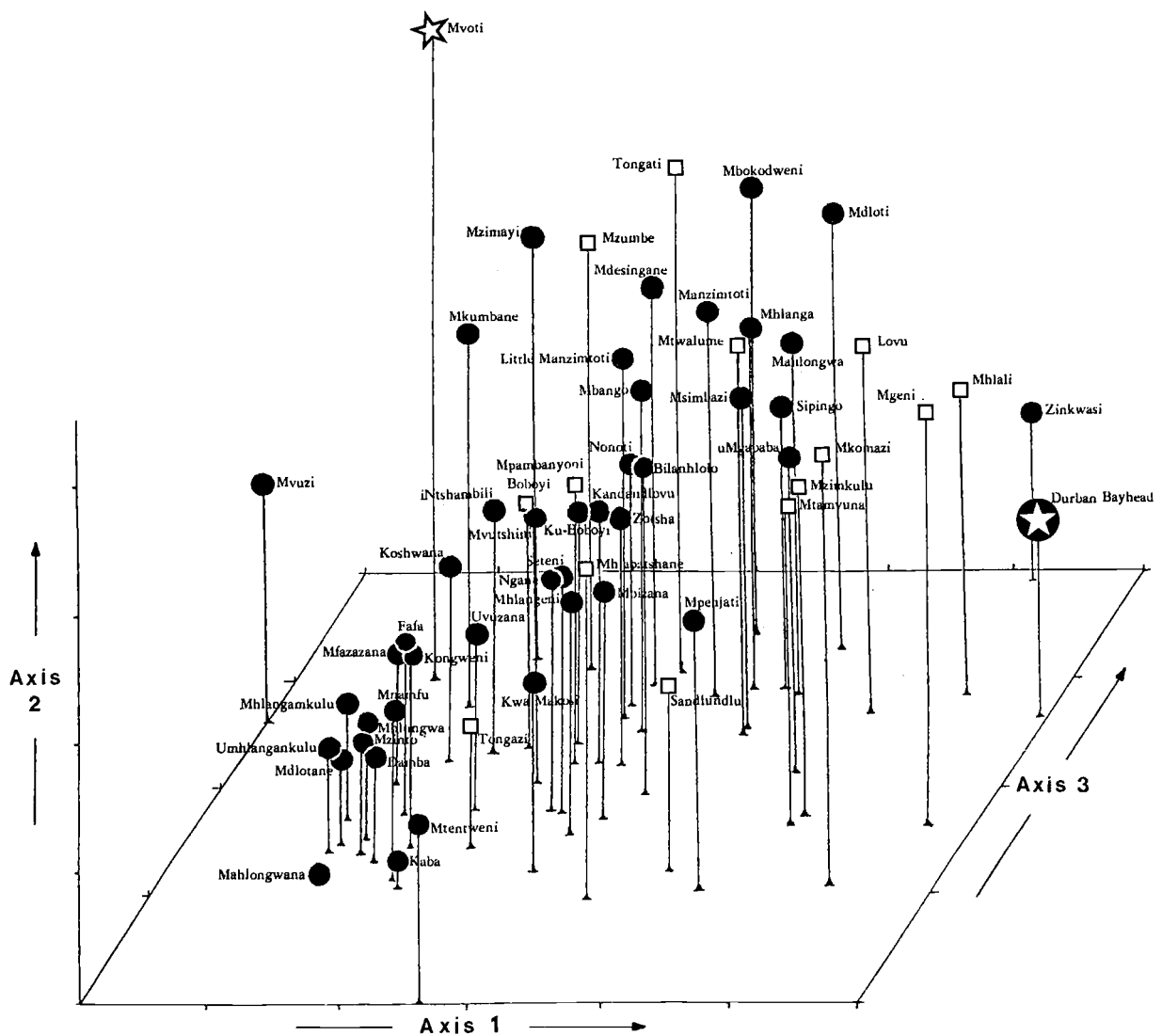

Fig.11 A three dimensional plot of the presence/absence data contained in Table 16. This allows the inter-relationships between the 59 estuaries represented to be viewed in a different perspective, and is complementary to the sample ordination in Fig.10.

Fig.12 The ordination of the fish species listed in Table 16 by detrended correspondence analysis. Axis 1 distinguishes freshwater species from stenohaline species. Three misplaced species were excluded because their chance association in certain systems confuses interpretation. These were Diplodus sargus (a marine species that may occasionally be carried into a lagoon by overtopping of the bar), Caranx ignobilis (a single specimen of which was taken in the Tongati, whilst in an unpolluted condition) and Anguilla bicolor (a catadromous species caught whilst in transit from sea to river in the Zinkwasi Lagoon).

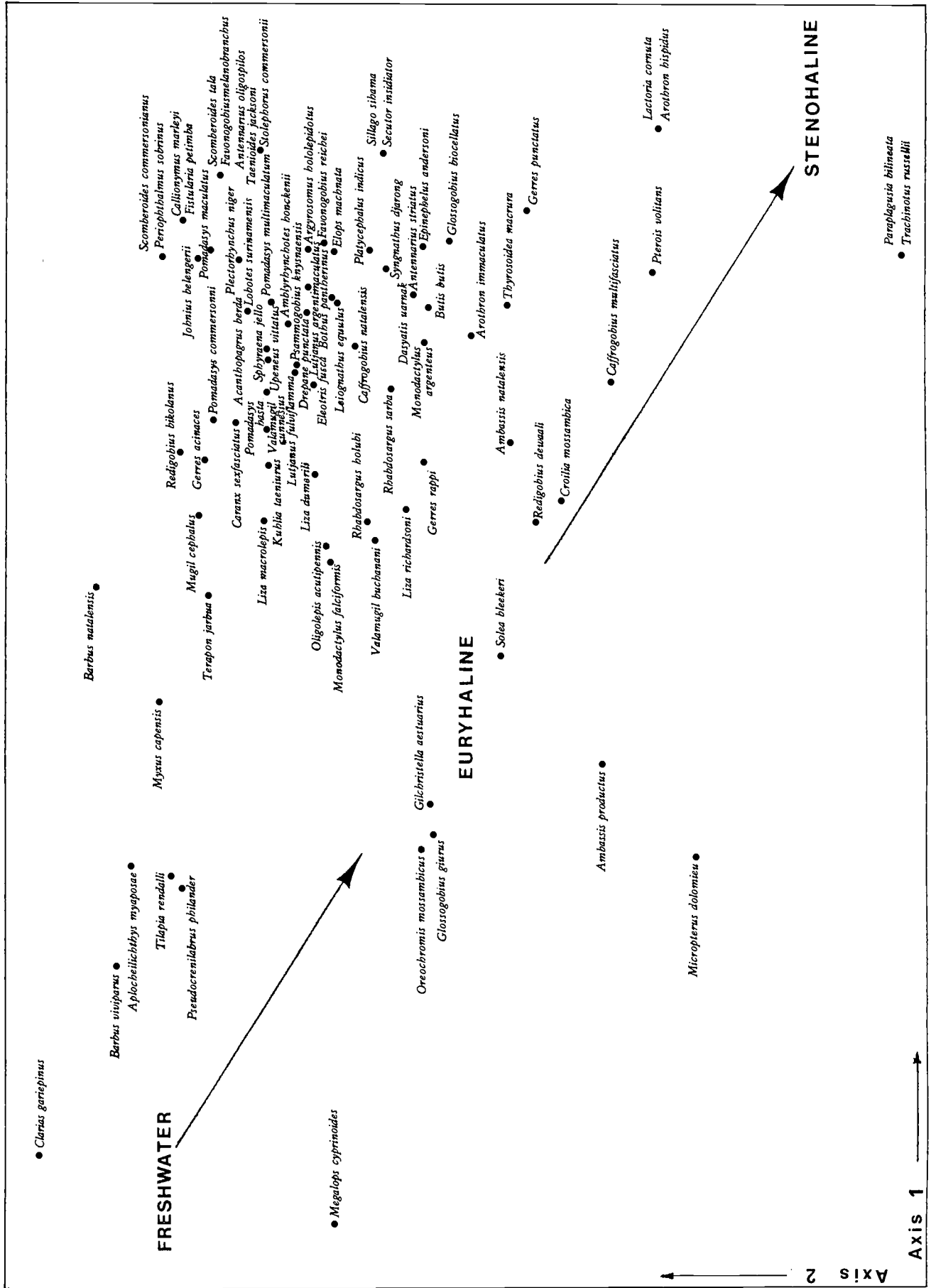

FIG. 12

Fig.13 The ordination of the prawn and crab species listed in Table 16 by detrended correspondence analysis. Axis 1 distinguishes freshwater species from stenohaline species. One misplaced species (Potomonautes sidneyi) has been excluded because its chance association in a backwater of the Mkomazi confuses interpretation.

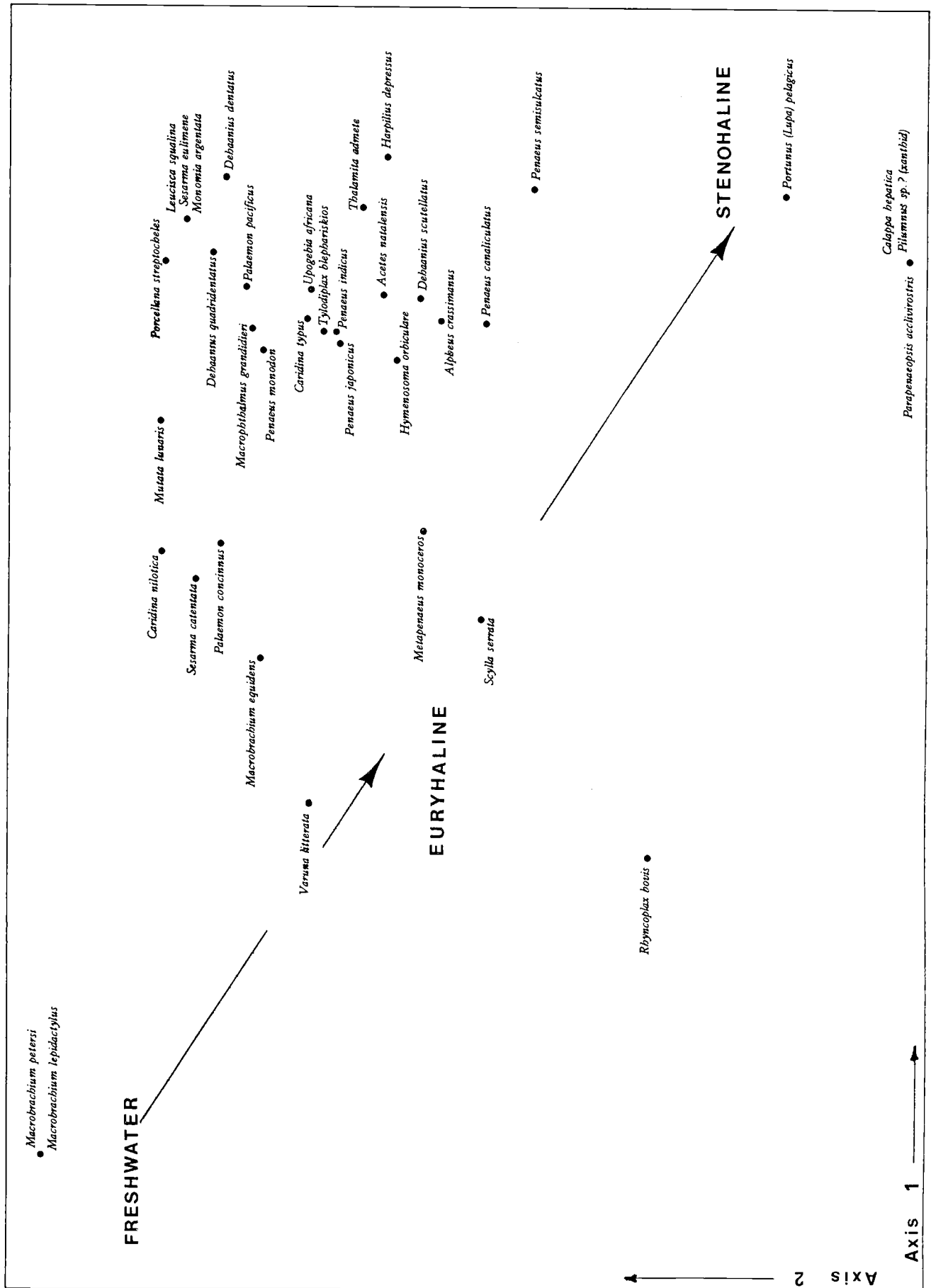

FIG. 13

Fig.14 The sample groups defined by ordination space partitioning after ordination of the data in Table 16 by detrended correspondence analysis. Seven sample groups (A-G) and five outlying samples can be identified. The latter are not given group status because of the reasons given in the text on outliers in Section 4.3.4. Using groupings established in Section 4.3.1, Group A is taken to represent a river mouth; Group B comprises systems on the verge of river mouth transformation (see text); with the exception of four systems (two of which are undergoing river mouth transformation), Groups C, D and E (collectively grouped by a broken line) are recognisable as lagoons; Group F comprises estuaries (sensu stricto) and Group G is recognisable as a bay. The distinctions between each of the symbols used are common to Figure 10.

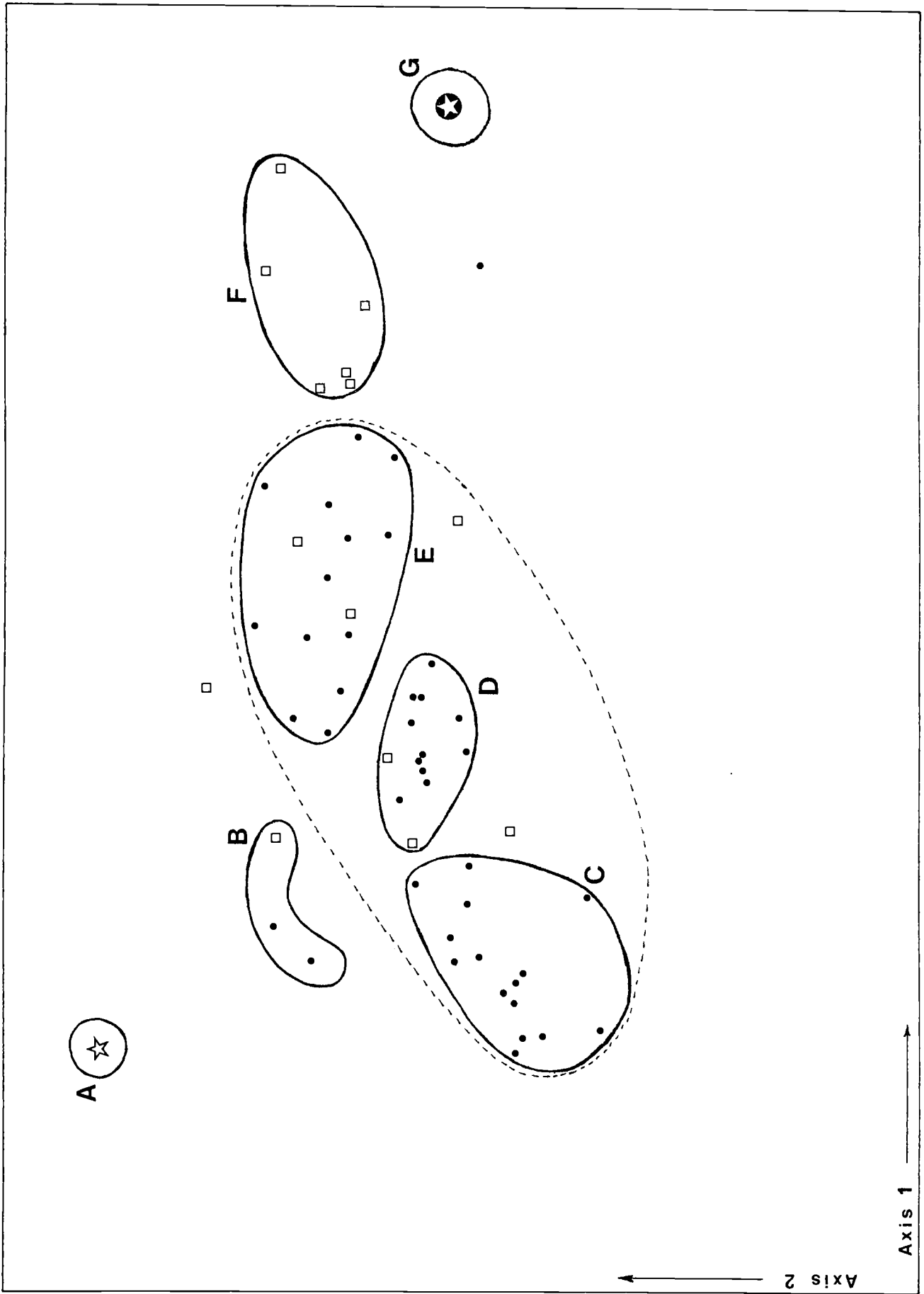

FIG. 14

Fig.15 The ordination of 59 estuaries in Natal by detrended correspondence analysis, using the CPUE data in Table 12 (Chap.3). Closed systems are distinguished from open systems along the first axis. The distinctions between each of the symbols used are common to Figure 10.

Table 17. A list of the environmental variables selected from the Appendix (unless otherwise indicated) to examine the distribution of each variable between the sample groups in Figure 14.

Name	Fig.	Definition
Mouth condition	16	the state of the mouth in terms of whether it is normally open or closed, based on data varying from daily observations over periods of up to six years, sporadic observations, aerial photography and local sources of information.
Catchment size	17	the area of the catchment grouped into four size classes (Begg, 1978).
System size	18	the area of the system grouped into four size classes (Begg, 1978; plus revised estimates in the Appendix.
Salinity	19	the mean of the bottom salinity measurements* made during the study period grouped into five classes according to the 'Venice System' (Spada, 1959). Marginal sites were excluded.
Depth	-	the mean of the depth measurements made during the study period grouped into three classes. Marginal sites were excluded.
Water transparency	21	the 'considered' mean** of the Secchi disc measurements made during the study period grouped into two classes.
Salinity stratification	22	a subjective assessment of whether salinity stratification was normally present or absent.
Substratum types	-	a subjective assessment of the principal substratum type (as defined in Table 7) based on the maps drawn of each estuary.

* Bottom salinity, because the community data derived by trawling came from the bottom of the system.

** Because the bottom of many systems was often visible, precise Secchi disc measurements were unobtainable, and this meant an arithmetic mean could not be calculated. For characterization purposes the 'considered mean' is a figure estimated by averaging the data obtained from the middle reaches of each system on those occasions the state of the system (Table 5) was regarded as typical.

4.3.3 Gradient analysis

a) Relation of sample groups to mouth condition

Figure 16 indicates that an open mouth condition is strongly associated with Groups A,F and G, whereas a closed mouth condition is strongly associated with Group C, and to a lesser extent with Groups D and E. The reasons for the association of 'open' systems in each of Groups D and E will be given in Section 4.3.4. In considering the influence of a single factor such as mouth condition, several other determinants must be taken into account. For example, mouth condition is a function of littoral drift, the geomorphology of the coastline, catchment size, mean annual run-off (MAR) and management practices such as dam construction and breaching (Fig.16a).

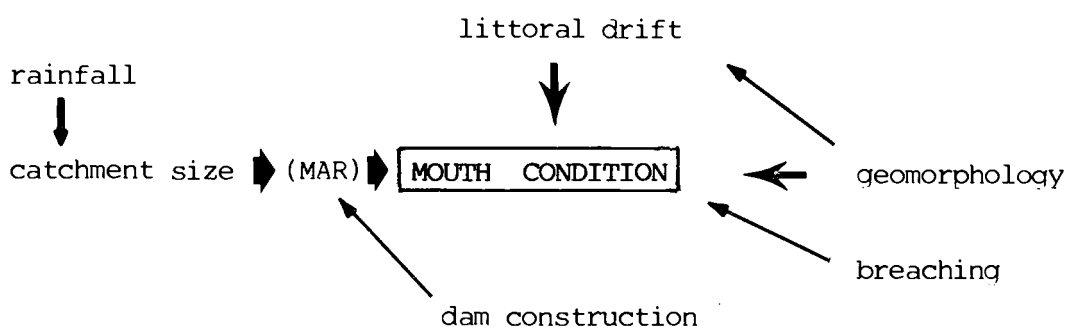

Fig.16a. Interactive diagram of the factors influencing mouth condition as a component of an estuarine ecosystem

Each of these factors exerts its own influence on mouth condition, and therefore can directly or indirectly account for minor variations in the sample positions in Fig. 10.

Another hypothesis is that the relationship between tidal exchange and mouth condition is one factor that cannot be given enough emphasis, and yet there are no data available to support this point of view. Because of the time consuming survey work which measurements of tidal prism would require, no attention was given to this subject, but it is probable that if the volume of water exchanged on each tide could be quantified, most of the variation between samples in an ordination such as Fig.10, could probably be accounted for with considerable precision. This is largely because of the relationship

Fig.16 The relationship of the seven sample groups and five outlying systems in Fig.14 to mouth condition.

Fig.17 The relationship of the seven sample groups and five outlying systems in Fig.14 to catchment size.

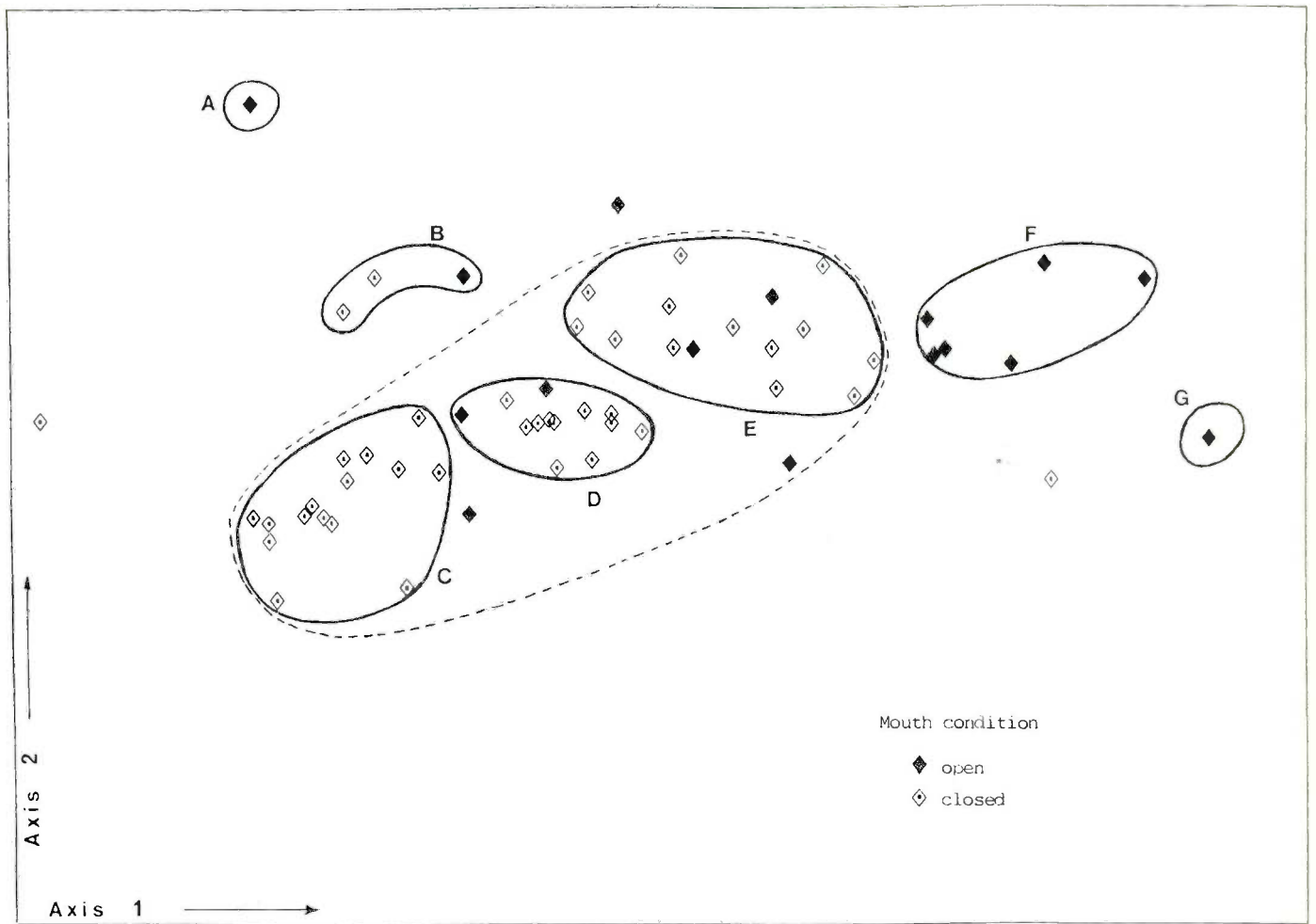

FIG. 16

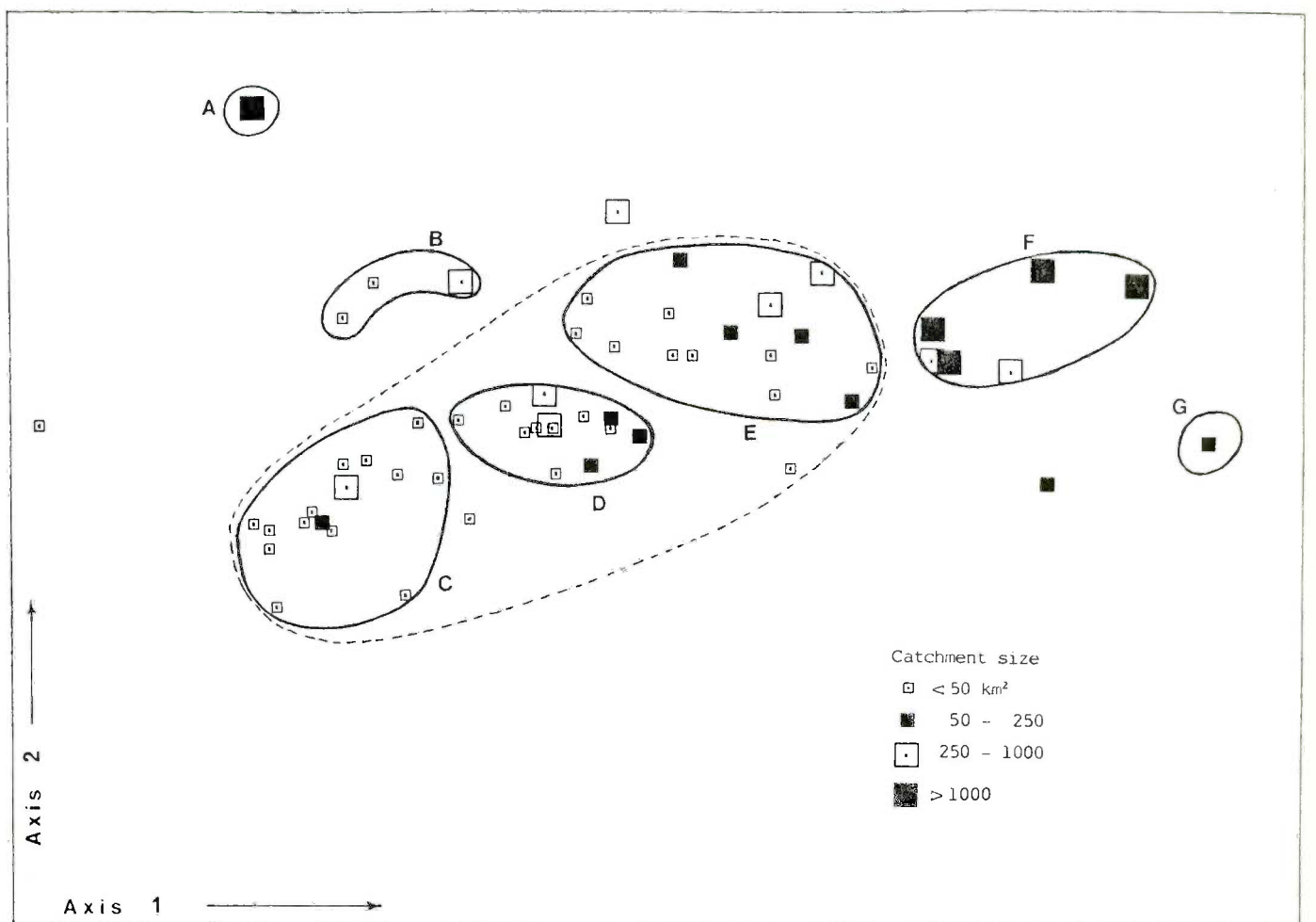

FIG. 17

which must exist between tidal exchange and the passive transport of organisms to and from the sea. Observation has shown for example that in certain systems, even while 'open', no exchange with the sea occurs even at high tide, as the water in the system remained outflowing throughout the observation period.

b) Relation of sample groups to catchment size

Figure 17 shows that large catchments ($>1000 \text{ km}^2$) are strongly associated with Groups A and F, whilst small catchments are associated with Groups C,D and E. There is a 'small to large catchment' gradient along the first axis of the sample ordination because catchment size and hence MAR directly influence the mouth condition, and therefore indirectly influence community composition.

c) Relation of sample groups to system size

Certain workers have suggested that larger systems are richer in species than smaller systems because of the greater variety of habitats within them. For example, Oviatt et al. (Siegfried,1981b: 233) "... found a two-fold variation in species richness and a ten-fold variation in abundance of birds at intertidal marshes ... and showed that these variations were more dependent on the size of the marsh than any other factor." In the context of the present study a different interpretation of the 'area effect' is offered.

There is a strong association between system size and the sample groups defined in Figure 18, because with the exception of the Lovu, Mkomazi and Mhlali, systems larger than 40 ha are confined to Groups F and G. For this reason there is a 'small to large system' gradient along the first axis of the sample ordination, especially if it is recalled that the size of estuaries in Natal have become considerably reduced over the past 50 years as a result of sedimentation (Chap.6). Systems such as the Lovu and Mkomazi in Group F were therefore formerly much larger than indicated.

However, the correlation between the sample ordination and size in this study is indirectly caused by mouth condition because the larger systems (Fig.18) are characterized by large catchments (Fig.17). The larger the catchment the greater the run-off and therefore the increased likelihood of keeping the mouth open. Size is therefore a coincidental relationship in the ordination which is

Fig.18 The relationship of the seven sample groups and five outlying systems in Fig.14 to system size.

Fig.19 The relationship of the seven sample groups and five outlying systems in Fig.14 to salinity.
(using the "Venice System" after Spada, 1959)

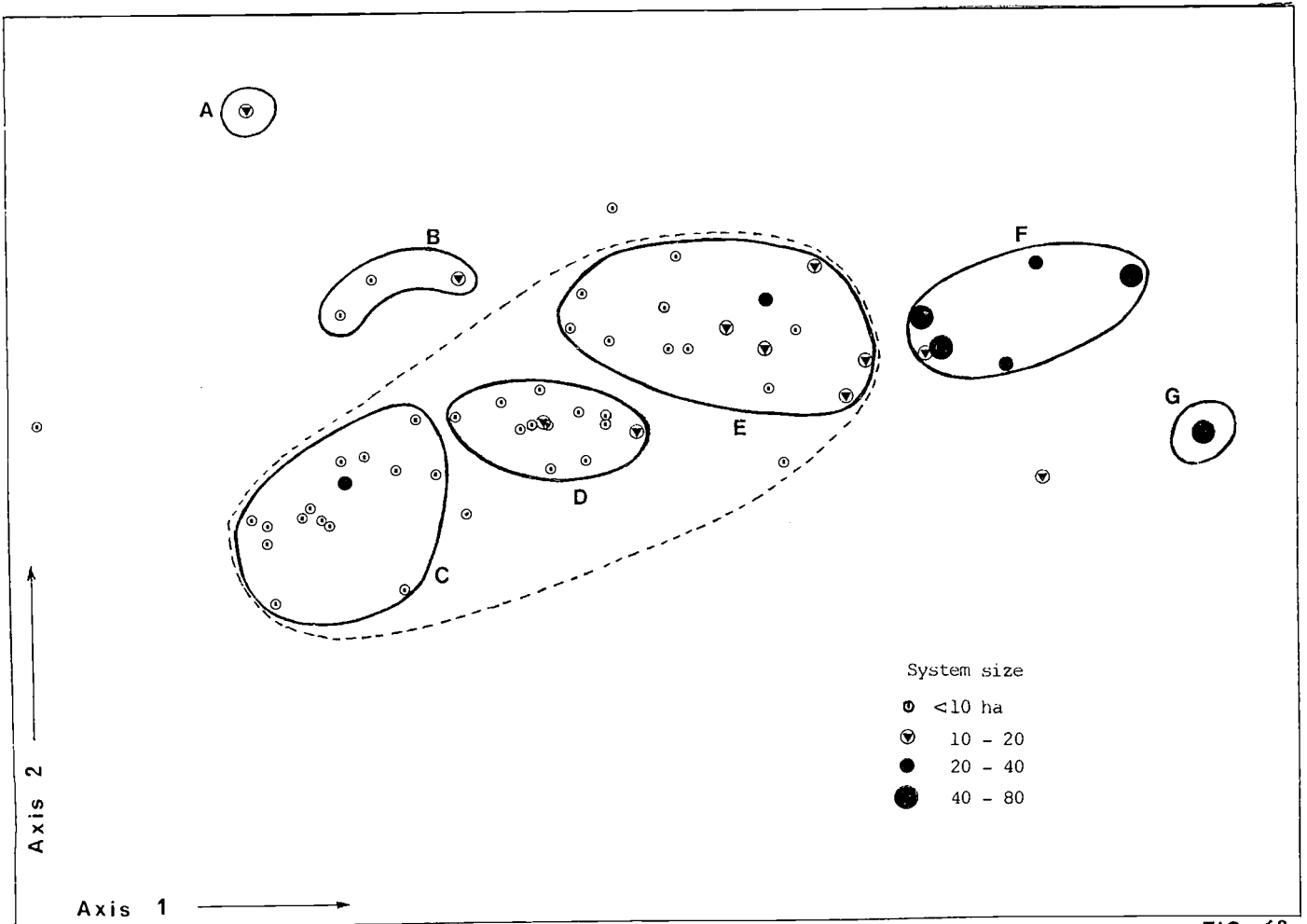

FIG. 18

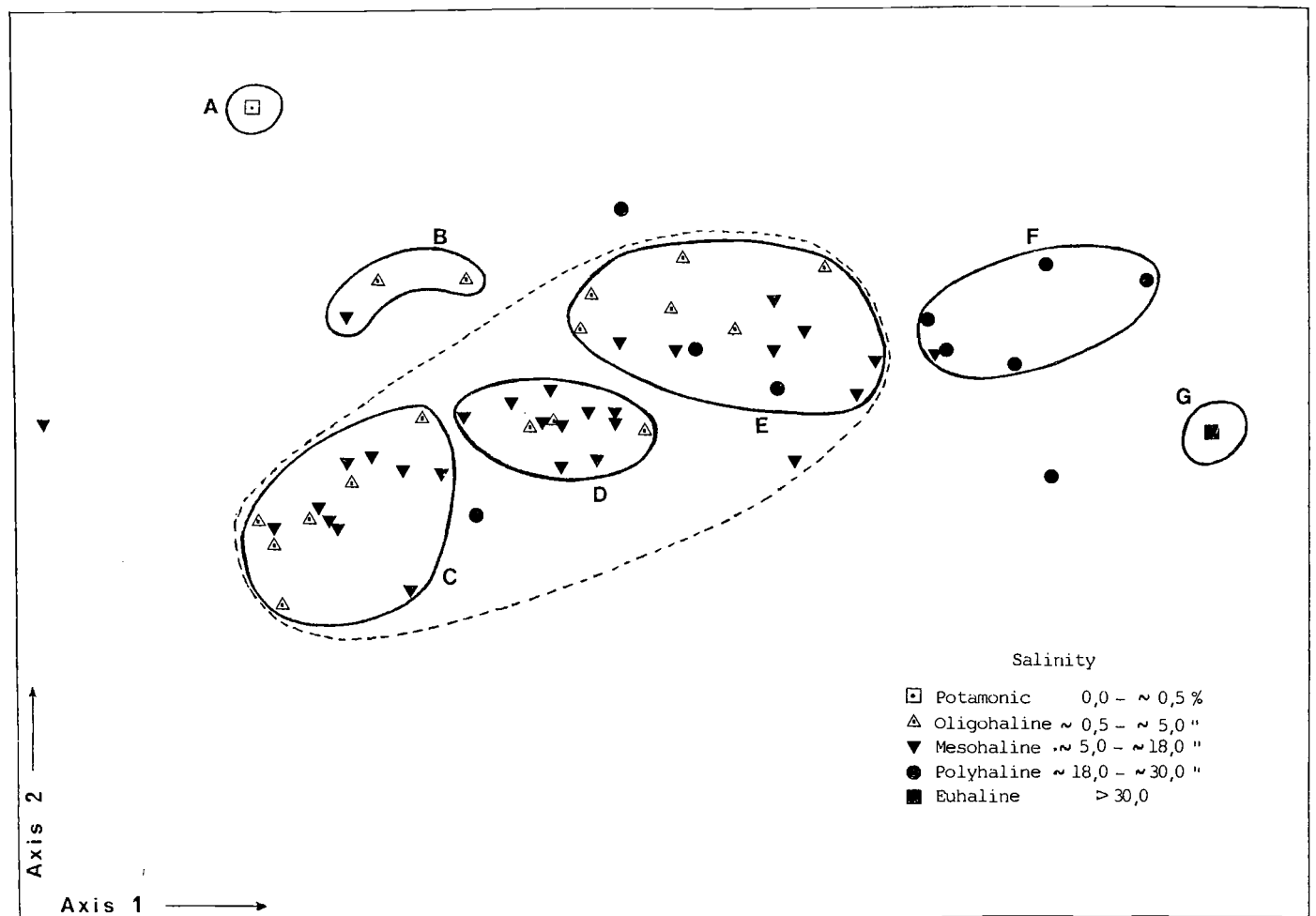

FIG. 19

unlikely to have any direct effect on differences in community composition between the sample groups. The poor species diversity in the Fafa (Group C) (Fig.7 , Chap 3) and its relationship shown in Figure 20, also tend to support this interpretation.

d) Relation of sample groups to salinity

So as not to impose any new concepts in a subject already as complicated as the classification of brackish water (Spada, 1959), the internationally accepted "Venice System" of distinguishing between different types of brackish water is used (Tables 10 & 15). The only deviation from the terminology adopted by the "Venice System" is replacement of the word limnetic (used to describe freshwater) with the term 'potamonic' (used to mean flowing freshwater; Bowmaker, pers. comm.) since this describes the physical condition of river mouths in Natal with greater accuracy.

Fig.19 suggests that Group A (Mvoti) is distinguishable from any other on the grounds that the system is potamonic, whereas Group G (Durban Bayhead) is clearly euhaline. The estuaries within Group F are strongly associated with polyhaline conditions. Within Groups C,D and E mesohaline systems are positively associated with Group D, but otherwise there is no marked association with salinity and any one group . . .

As in the case of mouth condition, a number of other interactive factors account for the salinity relationships in Figure 19. These

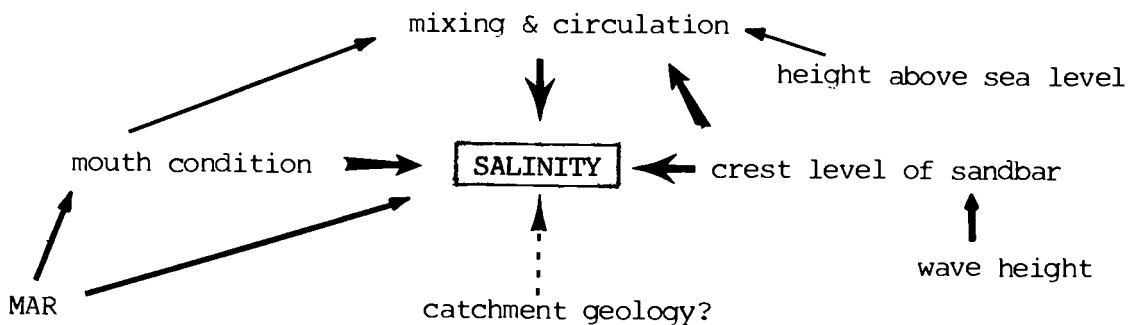

Fig. 19a. Interactive diagram of the factors influencing salinity as a component of an estuarine ecosystem.

include mouth condition (plus all its interactive factors, Fig. 16a), the crest level of the sandbar, the relative height of the system above sea level, tidal influences and circulation. In the case of the Zinkwasi even the catchment geology may be having an influence on salinity relationships (Fig. 19a).

By representing the relationships between estuary mouth condition, system size and salinity in three dimensions (Fig. 20), an attempt is made to show the type of relationships that multivariate analysis strives to reveal when using community data. This is done to emphasize that several environmental factors can simultaneously control community composition. Fig. 20 enables the distinction between open and closed systems, fresh and saline systems, and large and small systems to be visualized simultaneously.

e) Relation of sample groups to **water transparency**

Figure 21 suggests there is a strong association between reduced water transparency (turbid conditions) and sample Groups A,B and F. This therefore seems to be a characteristic feature of river mouths and estuaries (which are served by large catchments ,Figure 17) or systems undergoing river-mouth transformation (Chap.6).

The water in lagoons (Groups C,D & E) is generally clearer with Secchi disc measurements of over 100 cm as characteristic. The ratio of clear:turbid lagoons is higher in Group C (4:1) than in any other. The clarity of the water in Group G (Durban Bayhead) can be accounted for by its relatively great depth (dredged to 6,1m) and the limited inflow of water derived from land drainage.

These are valid relationships which are readily discernible in the field, but complicated by a variety of interactive factors (Fig.21a).

Fig.21 The relationship of the seven sample groups and five outlying systems in Fig.14 to water transparency.

Fig.22 The relationship of the seven sample groups and five outlying systems in Fig.14 to salinity stratification.

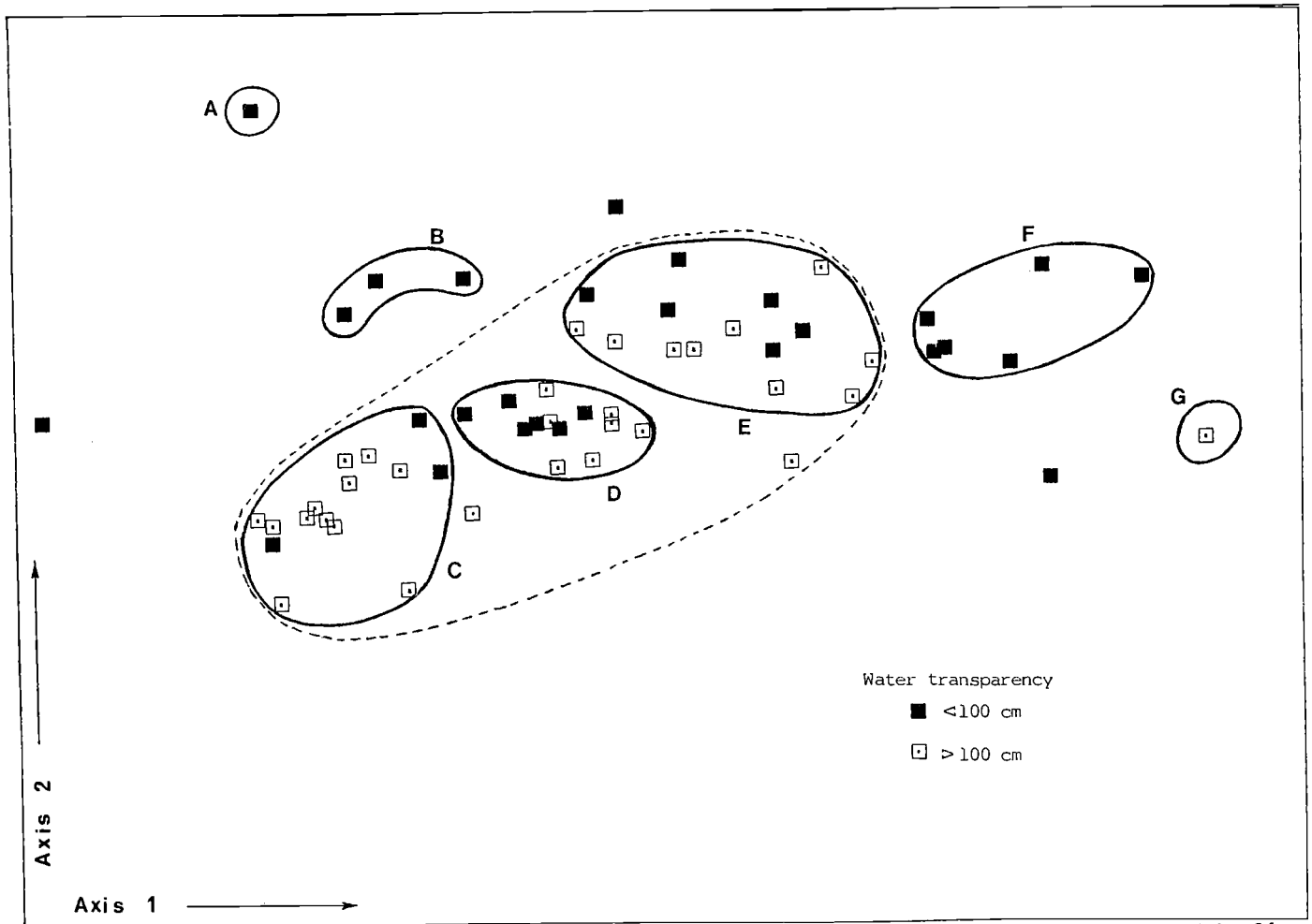

FIG. 21

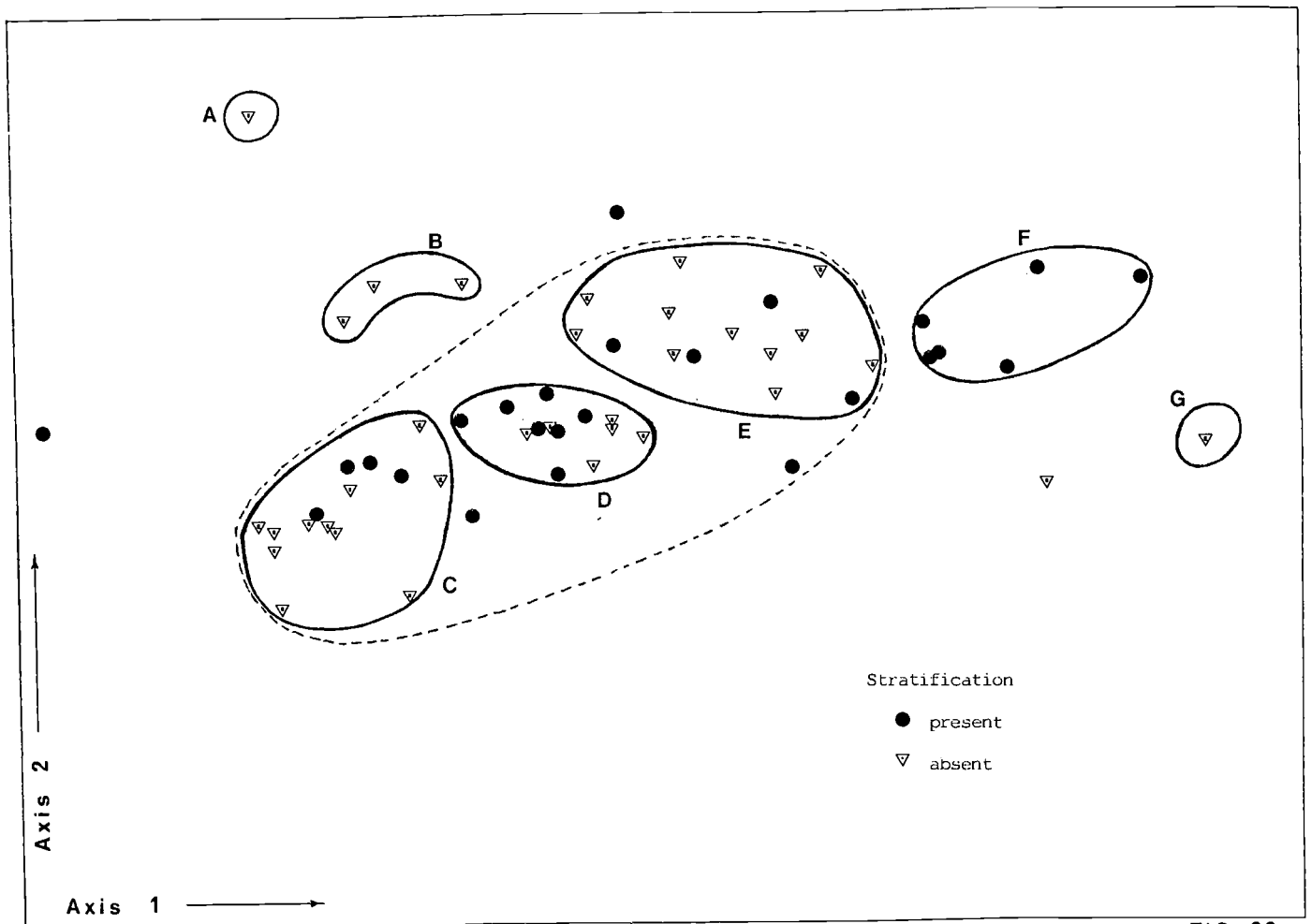

FIG. 22

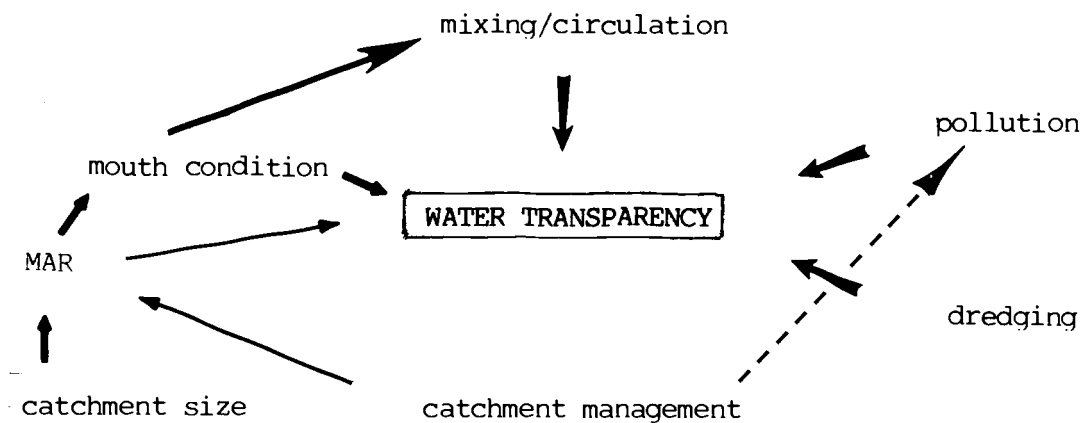

Fig.21a. Interactive diagram of the factors influencing water transparency as a component of an estuarine ecosystem.

f) Relation of sample groups to salinity stratification

Some clear correlations exist between the presence or absence of salinity stratification as an environmental variable, and the sample groups defined in Figure 22.

Being comprised of estuaries (sensu stricto) stratified systems are a characteristic of Group F, whereas Groups A and B are unstratified by virtue of their complete or partial transformation into river mouths. On the other hand, Group G (Durban Bayhead) is unstratified because it is basically a body of seawater and relatively little dilution by freshwater derived from land drainage occurs.

Within the systems classified primarily as lagoons (Groups C, D and E) no correlation exists between stratification and any particular group, although within Group D the ratio of stratified to unstratified systems (1:1) is higher than in any other. Generally speaking however stratification is not characteristic of lagoons because mixing is wind-induced (Table 15).

The interactions involved in an environmental relationship such as stratification are complex (Fig. 22a) because several factors such as mouth condition, circulation and salinity are involved. These are competing influences which tend to confuse interpretation of salinity stratification as an influential factor on community composition, where it is known for example to protect bottom-dwelling organisms that are intolerant of low salinities (Branch & Branch, 1981).

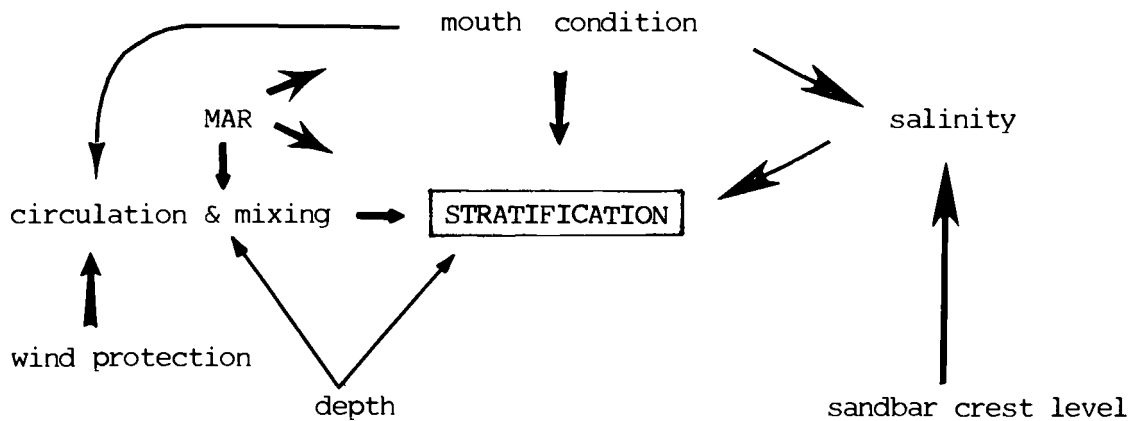

Fig. 22a. Interactive diagram of the factors influencing salinity stratification as a component of an estuarine ecosystem.

g) Relation of sample groups to depth and substratum type

Although both these environmental factors were examined in the same way as the preceding ones, neither was shown to exert an important influence on the ordination in terms of community composition. This may seem surprising because depth has a bearing on several other factors such as oxygen levels on the floor of the system and water transparency (see under 'e'), while substratum type is an important environmental influence in aquatic habitats (Hedgpeth, 1967). However, an intrinsic limitation of the analysis was the information loss that occurred when attempting to reduce the variety of substratum types that occur in most of the systems surveyed (see Appendix) to a single substratum type for the purpose of gradient analysis.

4.3.4 Final interpretation of the key ordination (Fig.10)

DCA is an ordination technique that has been purposely developed to define the two most ecologically meaningful community gradients within the first two axes of an ordination. The first axis assumes a horizontal relationship through the ordination, and generally represents the most powerful of the gradients involved. The second axis is orthogonal to the first, and represents the second most powerful gradient. In this section therefore generalities will be sought about species and community distributions along environmental gradients.

When viewed in terms of species space the 59 samples (or estuaries) depicted in Figures 10 and 11 are ordered along a community gradient with the Mvuzi at one end and Durban Bayhead at the other. The interpretation offered of this major gradient along the first axis of the ordination is **variation in mouth condition**, since those systems known to have open mouths are grouped together in close proximity to Durban Bayhead, whilst those at the opposite end of the gradient, and known to be infrequently in contact with the sea (such as the Mahlongwana, Mlotane and Mhlangamkulu for example) were closest to the Mvuzi. This interpretation is reinforced when mouth condition as an independent variable is examined in Section 4.3.3 (Fig. 18).

A second competing influence in the ordination is variation in salinity (Fig.19, Sect.4.3.3). In this case the Mvoti (which is completely fresh) is at one end of the scale and Durban Bayhead (with a bottom salinity averaging 31‰) is at the other. The fact that this gradient takes the form of a diagonal through the ordination confirms that mouth condition and salinity are closely related interactive factors (Fig.19a) but salinity is not as powerful an influence as estuary mouth condition. This is understandable on the grounds that physical processes such as the volume of water exchanged on each tide are more dominating influences in an ecosystem of this nature, than factors such as the salinity of the water being exchanged (Pritchard, 1967).

When viewed in terms of samples space, the 121 species depicted in Figures 12 and 13 are also ordered along a community gradient with freshwater species (such as Clarias gariepinus) at one end and stenohaline species (such as Lactoria cornuta) at the other.

The interpretation offered is that the species are ordered along this axis on the basis of their salinity tolerance. Freshwater species occur at one end of the axis, stenohaline species at the other, and euryhaline species in between. It follows that the gradient is a direct reflection of the osmoregulatory abilities of the species involved*.

Naturally, certain species will reach the limits (or optima) of their salinity tolerance along the gradient, and be replaced by other more tolerant species. This is known as a species "turnover" (Gauch, 1982), but overall, community variation is continuous, and when the sample ordination (Fig.10) is compared with the species ordinations (Figs. 12 & 13) the two are clearly governed by the same determinants, namely mouth condition and salinity.

If the overlays of Figures 12 and 13 (which are provided as pull-outs) are superimposed upon Fig.14, another important feature in the species ordinations is that the region of greatest diversity is confined to the right hand side of the ordination, whereas the opposite occurs in the sample ordination. The reason for this is discussed in Section 4.4, but in essence means that open systems (on the right hand side of the ordination) are species rich because of utilization by species of marine origin.

* The most surprising of the various associations shown is perhaps Micropterus dolomieu (smallmouth bass) as this is a species not normally associated with brackish water. This fish was nevertheless taken in 16% from the Zotsha Lagoon (see Appendix).

4.3.5 Final interpretation of Figure 15.

Ordination of the data contained in Table 12 also produced a readily interpretable result (Fig.15) although outwardly dissimilar to the ordination based on presence/absence data (Fig.10).

The systems remained clearly ordered along the first axis according to variation in mouth condition, with closed lagoons (in this case epitomised by the Kaba) at one end, and Durban Bayhead as an open system at the other. This particular arrangement of the samples is considered to be most realistic because estuaries such as the Lovu, Mtwalume, Mpambanyoni and Tongati, which suffer from mouth closure are all placed slightly to the left of an obvious zone of discontinuity in the ordination that may well separate functional estuaries (i.e. functional as a nursery area for marine species) from less-functional estuaries and lagoons. Furthermore, closed systems such as the Zinkwasi are realistically placed, as well as open systems such as the Mvoti.

The primary difference between the two ordinations lies in the fact that only the sample arrangement along the first axis is ecologically meaningful. In other words, the salinity gradient along the second axis of Figure 10 is not discernible in Figure 15.

One of the most noticeable shifts is in the position of the Msimbazi. This is because abundance values have been used, and so the most abundant species present (namely Oreochromis mossambicus and Glossogobius giurus, (see Table 40, of the Appendix) account for its association with systems such as the Fafa, in which these species are equally abundant. On the other hand, using presence/absence data (Fig. 10) the Msimbazi occupies a borderline position close to the boundary that separates estuaries from lagoons on the basis of community composition. This seems attributable to its relatively high salinity (see Appendix).

If the data expressed in Table 14 (Chap.3) are transferred to Figure 15 the opinion given in Chapter 3 that certain species are more common in closed systems than they are in open systems is strengthened (Fig.23). There is a distinct gradient in the relative abundance of the four lagoon-associated species specified in Table 14 along the first axis of the ordination. The magnitude of this gradient ranges from abundance values (expressed as a percentage of the total catch) of 98% at one end of the first axis to 1% at the opposite end of the

Fig.23 The comparative proportions of four common lagoon-associated species (Gilchristella aestuarius, Glossogobius giurus, Oreochromis mossambicus and Rhyncoplax bovis) expressed as a percentage of the total catch (Table 14) in relation to the sample arrangement in Figure 15.

first axis. This is a direct reflection of the effect of mouth closure on the relative abundance of those species capable of completing their life cycle within the confines of a closed system.

Having offered an explanation for the two major environmental influences in both ordinations, the inter-relationships between each system can now be meaningfully discussed.

Group A

A sample more different in terms of its community composition from any other is the Mvoti. This system assumes a position of its own in the top left hand corner of the ordination (Fig.10), and is designated as Group A (Fig.14).

It will be recalled that having been infilled by sediment, the bed level of the Mvoti lies above sea level and in this condition it is atidal (see Appendix). It has also become shallow and potamonic (Fig.19). Since the Mvoti drains a large catchment measuring 2 651 km², a constant flow of fresh (albeit polluted) water normally maintains the mouth in an open condition (Fig.16). On these grounds alone the Mvoti differs from any other system studied, but as a result is equally distinctive from a biological point of view (refer to overlays of Figs.12 & 13, in conjunction with Fig 14). The organisms associated with the Mvoti such as C. gariepinus, Barbus viviparus and Macrobrachium petersi are freshwater species, which exist in the Mvoti because of the lack of any marine influences. They are indicative of an environment totally dissimilar to an estuary such as the Mgeni for example.

On the grounds that systems such as the Mvoti are ecologically distinct and to prevent any ambiguity, and more importantly, for management, research and conservation purposes, it is therefore recommended that in Natal this type of system be recognised as a **RIVER MOUTH**, thus confirming the provisional classification (Sect.4.3.1.) based on environmental variables. Day (1981) makes precisely the same distinction when describing the Orange (on the west coast of South Africa) and the Tugela.

Group B

A group of systems apparently more similar to the Mvoti River mouth than any other is the Mkumbane, Mzimayi and Mzumbe (Group B). All three systems are shallow (see Appendix), unstratified (Fig.22) and characterized by water of low transparency (Secchi \leq 100 cm, Fig.21).

In reality, the community structure and physical condition of the Mzumbe is more similar to the Mvoti than either the Mkumbane or Mzimayi (Figs 16,18,21,22 and 23) and so for classification purposes it is recommended that the Mzumbe be regarded as a river mouth. It differs from the Mvoti in terms of community composition because of periodic mouth closure, intermittent periods of salinity stratification in its lowermost reaches, and the existence of an atypical backwater (comprising a pool isolated from the main channel behind the northern bridge embankment (grid ref.0912, Fig. 70, in the Appendix).

What is important about this grouping is the fact that field observations suggest that all three systems are on the verge of river mouth transformation (see Appendix and Sect.4.4) having been grossly infilled by sediment. Therefore, the Mzimayi and Mkumbane have lost their association with the lagoonal group (see below) and the Mzumbe has long since lost its identity with the estuary group (Group F). In summary, all three systems are most realistically placed in the ordination. This demonstrates the sensitivity of multi-variate analysis, and shows that by examining community structure DCA provides a far deeper insight into the nature of these systems than provided by the provisional classification.

Groups C, D & E

With the exception of the Mpambanyoni (in Group D) and the Mtwalume (in Group E) seventy percent of the systems comprising the rest of the data set lie within a region of the ordination distinguishable on the basis that contact with the sea is discontinuous (Fig.16) and their salinity normally encompasses both oligohaline and mesohaline ranges (Fig.19). The exceptions to this general rule are discussed below, but according to the Concise Oxford Dictionary (1951) "a stretch of salt (or brackish) water parted from

the sea by a low sandbank ..." is described as a lagoon. The Natal coastline is also a region which is internationally recognized as lagoonal by Leont'ev & Leont'ev and Gierloff- Emden (Barnes,1980:2) because of sand movement in the littoral zone (estimated at 600,000 m³ per annum , Swart pers. comm.) . This in turn is due to the high energy dissipated by waves along this particular bit of the African coastline. It is also clear that without exception these systems lie at the end of relatively small catchments (generally >1000 km² in extent, Fig. 17). The run-off from catchments of this size therefore appears to be inadequate to maintain the mouth in an open condition, and so lagoons are also distinguishable from a hydrological/hydraulic point of view. Finally, this type of coastal feature is biologically distinctive because, with reference to the species ordination (refer to the overlays of Figs 12 & 13) the systems distinguished in the same region of the sample ordination (Fig.14) are characterized by relatively few species . Furthermore, these species are recognized as being able to complete their life cycle within the confines of a closed system, and thus have become independent of a requirement such as access to the sea. For example, species such as Oreochromis mossambicus, Glossogobius giurus, Gilchristella aestuarius, Rhyncoplax bovis and Macrobrachium equidens lie within this region of the ordination. The relative abundance of four of these particular species in closed systems has also been emphasized in Table 14, Chapter 3. It is therefore recommended, for the same reasons given earlier that this type of system in Natal becomes recognised as a LAGOON.

Rigid compartmentalization however does not occur in nature (Barnes,1980) and especially so when a continuum of variation, or gradient in community composition (or coenocline) is involved such as that in Fig. 10, and when systems such as the lagoons of Natal are so numerous. Considerable intergradation occurs, but the key determinants of the community structure within each system, remain as factors related to mouth condition and salinity, as will become apparent from the discussion of each group below.

Group C

Ranked along the first axis the systems comprising Group C are the Umhlangankulu, Mhlangankulu, Mdlotane, Mahlongwana, Mhlungwa, Mfazazana, Mzinto, Damba, Koshwana, Fafa, Kongweni, Mnamfu, Kaba, iNtshambili and Uvuzana.

All of these are normally closed (Fig. 16). Six of the 15 systems represented are oligohaline, whereas nine are mesohaline (Fig. 19). With the exception of the Fafa, they are also all smaller than 10 ha in size (Fig. 18). Stratification is only characteristic in four of the systems listed (Fig. 22), and within 12 of them light penetration is normally greater than 100 cm (Fig. 21).

Group C is also realistic, although the iNtshambili is a lagoon that outwardly appeared to differ from any other in the study area. This is because the iNtshambili was found to be markedly affected by the swamp forest that surrounds it, through leaf-fall and macrodetrital loading. These materials discolour the water and indirectly create marked oxygen deficiencies (see Appendix).

Another feature common to five of the systems in Group C is the presence of submerged macrophytes such as Najas marina and Potamogeton pectinatus. The same five systems are all oligohaline, and so this plus the static water level in each, seems to be conducive to the development of these particular plant communities.

In conclusion, the provisional classification of these systems as lagoons in Sect. 4.3.1. is confirmed by multi-variate analysis of community data.

Group D

Ranked along the first axis, the systems comprising Group D are the Boboyi, Mvutshini, Ku-Boboyi, Seteni, Mpambanyoni, Nonoti, Ngane, Kwa-Makosi, Kandandlovu, Mtentweni, Mhlangeni, Zotsha and Mbizana.

It is normal for the mouth condition of the systems within this group to be closed (Fig 16), but within Group D are two systems which can be regarded as open under extenuating circumstances. Also, with the exception of two systems they are all smaller than 10 ha in size (Fig. 18) and the ratio of mesohaline to oligohaline systems is greater in Group D (2.25:1) than in either Group C (1.5:1) or Group E (1:1) (Fig. 19). A possible 'misfit' in Group D is the Nonoti, because

it is oligohaline and ,in addition , noted for the presence of submerged macrophytes. These plants are not characteristic of the other two oligohaline systems in Group D, but nevertheless suggest that the Nonoti has several affinities common to Group C.

The two open systems referred to are the Boboyi and the Mpambanyoni. The extenuating circumstances particular to these systems are that the Boboyi is a system perched above sea level and the 'open' mouth is really an overflow channel maintained artificially by the backwash from the filters of the LSCRWSC (see Appendix). Because it is atidal, but saline ,its fauna is lagoon-associated. Consequently there is good reason to suggest that the system should be recognised as a lagoon, and not as an estuary as initially suggested in the provisional classification.

In the case of the Mpambanyoni however, the system is estuarine by definition (Table 15) but only partially so in terms of community structure (Table 55, in the Appendix) due to the effects of periodic mouth closure and acute sedimentation. For classification purposes therefore the Mpambanyoni should still be regarded as an estuary, but one that is tending towards river mouth transformation (Chap. 6) and hence has lost its identity with the estuary group (Group F). The proportion of lagoon-associated species (Fig. 23) is reflective of this transition, as well as its relative position in Figure 10.

With the exception of the two systems mentioned above, analysis of the community data from the systems comprising Group D therefore largely confirms the provisional classification of these systems as lagoons in Sect. 4.3.1. On the basis of its community structure however, it would appear justifiable to regard the Boboyi as a lagoon and not as an estuary.

Group E

Ranked along the first axis the systems comprising Group E are the Little Manzimtoti, Mdesingane, Mbango, Manzimtoti, Bilanhlolo, Mbookodweni, Mhlabatshane, Mhlanga, Sipingo, Msimbazi, Mtwalume, Mahlongwa, Mloti, Mpenjati and uMgababa.

These systems are broadly similar to those in Groups C and D, but are of particular interest because of the transitional position some of them occupy in the ordination between those systems regarded

as lagoons and those regarded as estuaries (Group F).

As in the case of the Mpambanyoni in Group D, the Mtwalume occurs within Group E as an estuary which is losing its association with the Group F because of periodic mouth closure (a result of bridge construction) and river mouth transformation (a result of sedimentation). In the likely evolutionary sequence of events that occur the Mtwalume therefore seems to be realistically placed in the ordination as an estuary undergoing river mouth transformation.

Two other systems that warrant special mention are the Mpenjati and the Mloti, both of which are lagoons in which the mouth condition is interfered with by breaching (see Appendix). This enhances utilization by estuary-associated species, and so their proximity to the estuary Group F is to a certain extent considered as artificial.

The Mhlabatshane also occurs within Group E as an estuary (according to the provisional classification) but as a lagoon if its community structure is taken into account (Fig. 23). What is significant is that the open mouth condition of the Mhlabatshane is artificially maintained (see Appendix). This also accounts for the polyhaline nature of this lagoon (Fig. 19). The polyhaline nature of the Sipingo on the other hand is due to freshwater diversion and evaporation. Exchange with the sea in the Sipingo is in fact restricted to two concrete pipes (see Appendix).

The position of the Msimbazi and Mahlongwa should be noted because both are remarkably saline lagoons (15%). What is of particular interest is the different position the Msimbazi occupies in species space when CPUE data (abundance values) are used (Fig. 15), thereby showing its lagoonal status in another perspective.

In conclusion, with the exception of the Mhlabatshane and the Mtwalume, analysis of the community data from the systems comprising Group E confirms the provisional classification of these systems as lagoons (Sect. 4.3.1.). On the basis of its community structure however, there is good reason to suggest that the Mhlabatshane is not an estuary, but a lagoon, and in spite of its mouth being maintained artificially in an open condition.

Group F

The systems comprising Group F are the Mtamvuna, Lovu, Mzimkulu, Mhlali, Mkomazi and Mgeni.

These are distinguishable on the grounds that each was broadly similar in terms of their community structure. The community composition of these systems was considerably more complex and distinctly different from that of lagoons (refer to overlays of Figs 12 & 13). A far greater variety of organisms are encountered in this region of the species ordination than anywhere else, and more importantly many of these are regarded as being of economic significance to man. They include popular angling species of fish such as Argyrosomus hololepidotus, Pomadasys commersonii and Rhabdosargus holubi; as well as commercially important prawns such as Penaeus indicus and P. monodon, and crabs such as Scylla serrata. Clearly these systems are those supportive of the species regarded by so many authors as estuary dependent (Wallace, 1975; de Freitas, 1980; Day, 1981) and thereby fulfilled a nursery function as far as recruitment of marine stocks is concerned.

A number of abiotic features also distinguish this sample group from any other. To begin with the mouth condition is normally open (Fig.16); with one exception, the salinity regime is polyhaline (Fig.19); salinity stratification is characteristic (Fig.22); water transparency is low (Fig. 21) and, with one exception they are relatively large bodies of water (>20 ha, Fig.18) because (with two exceptions) they lie at the receiving end of large catchments (>1000 km² in size (Fig.17).

Elsewhere in the world these are the sort of biotic and abiotic characteristics attributed to **ESTUARIES** (Cameron & Pritchard, 1963; Douglas & Stroud, 1971) and so to prevent any ambiguity it is recommended that the same word be used to describe such systems in Natal. This may seem a trivial distinction to make, until one realizes how few of the 62 systems studied fall into this category; how many systems are on the verge of losing identity with Group F, or have already lost it.

Certain of the associations in Group F such as the apparent similarity between the Lovu and Mzimkulu are not regarded as valid, because unlike the Mzimkulu, the mouth of the Lovu Estuary often closes. Their relative positions in species space are better

represented when viewed in three dimensions (Fig.11). Within this Group, the provisional classification of the six systems concerned as estuaries has been confirmed and strengthened by the strong similarities in community structure.

Group G

The last sample group in the ordination is Group G, which comprises Durban Bayhead. This system represents the endpoint in the continuum of variation between river mouths, lagoons and estuaries in the study area, and is considered aptly named as a BAY (or inlet) of the Indian Ocean.

Durban Bayhead is distinguished by its euhaline salinity regime (Fig 19), and in terms of community structure (refer to overlays of Figs 12 & 13) by stenohaline species such as Portunus pelagicus, Lactoria cornuta and Arothron hispidus, all of which are species commonly found in the sea. This biotic response confirms the provisional classification of Durban Bayhead as a bay in Sect. 4.3.1.

Outliers

Five systems within the ordination lie beyond the clusters defined as Groups A-G. These are the Mvuzi, Tongati, Tongazi, Sandlundlu and the Zinkwasi.

The dissimilarity of the Mvuzi is caused by the trawl recovery of a single Megalops cyprinoides in the system (Fig. 12). When abundance values are used (Fig. 15) the influence of this species in the ordination is lost, and the Mvuzi assumes a more realistic position in association with closed systems such as the Damba and Mhlangamkulu, and therefore should be classified as a lagoon.

The Tongati should be classified as an estuary despite the fact that it does not associate with the estuary Group F. It cannot be expected to do so when it is normally so polluted that there is no resemblance between the two in terms of community structure (see Appendix). Just as significant is the fact that when rid of the pollutants in the system (by means of a flood in September 1980) estuary-associated species were quick to return to the system for a few months (Table 14, in the Appendix). Once the Tongati Estuary becomes polluted its aberrant nature therefore causes the system to be outlying of its true position in the ordination.

Sampling of the Tongazi was never regarded as satisfactory because of the rocky nature of the bottom (see Appendix), and this could account for the placement of the Tongazi amongst a group of lagoons. Until further data can be obtained, the decision made is to regard the Tongazi as an estuary for classification purposes, but sight should not be lost of the fact that the mouth is severely throttled by sand, thereby reducing tidal exchange. This physical feature of the system could have exerted sufficient influence on community structure for the Tongazi to have been accurately portrayed in the ordination as a lagoon.

The Sandlundlu is regarded as very much of a borderline case, but for the purposes of classification is, at this stage, also regarded as an estuary on the grounds that its community structure (see Table 127, in Appendix) and its prevailing mouth condition are estuarine. The latter is however, an assumption based on hearsay (van Duyn, pers. comm.) and may in time be shown to be otherwise. In this case, like the Tongazi, the Sandlundlu may in fact have been accurately portrayed as a lagoon.

The outlying position of the Zinkwasi is almost certainly related to its abnormally high salinity (Fig. 19). This may well be due to the crest level of the sandbar across the mouth being at a lower elevation than elsewhere on the coast, and hence permit more frequent overtopping of the bar at high tide. It may also have something to do with the geology of its catchment, since the conductivity of the Zinkwasi River is higher than any other in Natal (Brand et al., 1967). The geographical location of the Zinkwasi, may also partly account for its different community structure, because it is the most northerly of all the systems studied, and therefore closer to the Tugela Bank than any other. Whatever the reason, the high salinity of this system means it can support a greater variety of estuary-associated organisms than many other similarly closed systems. It is the only example of a system which, in spite of the community structure being markedly estuarine, in my view, should still tentatively be classified as a lagoon because of the relatively high proportion of lagoon-associated species (Fig. 23) within the community, and its closed mouth condition (Fig. 16). However, this anomalous situation obviously warrants further research.

4.3.6 Conclusions

Because of the inherent complexity of community ecology, the interpretation of any ordination is naturally reliant upon an appreciation of the subject that only the investigator can be expected to provide. Just as in the choice of the ordination technique, this means that a certain amount of subjectivity is unavoidable, but this, I feel is justified in light of the preceding interpretations.

The distinction between bays, estuaries, lagoons and rivermouths appears to be valid, and adoption of these terms in Natal is therefore recommended. By using DCA for the ordination of selected data from the Appendix a distinct coenocline related to gradients in certain environmental features is discernible. The most influential of these is variation in mouth condition and salinity. These community gradients (Fig. 23) lend considerable support to the null hypothesis in Chapter 2 that "not all estuaries in Natal perform the same ecological function", as well as to the provisional classification postulated in Table 15. In view of this, an improved method for classifying "estuaries" in Natal is proposed (Table 18). Herein certain environmental variables (such as mouth condition, salinity and the tidal prism) are used in conjunction with the community structure of each system. Accordingly, slight modifications are made where necessary to the listing of the systems in the study area in Sect. 4.3.1. These are based on a reclassification of certain systems using Table 18 instead of Table 15 as well as the relative position of certain systems in Figure 10. The results are presented below :

BAY Durban Bayhead

ESTUARY (functional)

Mhlali, Mgeni, Lovu, Mkomazi, Mzimkulu, Mtamvuna

 (semi-functional)

Tongati, Tongazi, Sandlundlu

 (verging on river mouth transformation)

Mpambanyoni, Mtwalume

Table 18. A revised basis for the classification of "estuaries" in Natal.

COASTAL FEATURE	ENVIRONMENTAL VARIABLE				COMMUNITY STRUCTURE (typical genera)	COMMUNITY
	Mouth Condition	Tidal prism	Mixing mechanism	Salinity*		
BAY	permanently open	large	tide	euhaline (~ 30‰)	<u>Amblyrhynchotes</u> ; <u>Leiognathus</u> <u>Harpilius</u> ; <u>Penaeus semisulcatus</u> <u>Portunus</u> ; <u>Dehaanius</u>	MARINE fish prawns crabs
ESTUARY	open	moderate	tide	polyhaline (~ 30-~ 18‰)	<u>Rhabdosargus</u> ; <u>Pomadourys</u> <u>Penaeus monodon</u> , <u>P. japonicus</u> , <u>Upogebia</u> <u>Scylla</u> ; <u>Hymenosoma</u>	ESTUARINE fish prawns crabs
LAGOON	closed	small	wind	(~ 18- ~ 5‰) mesohaline --- oligohaline (~ 5-~ 0, 5‰)	<u>Oreochromis</u> ; <u>Glossogobius</u> <u>Macrobrachium equidens</u> <u>Rhyncoplax</u> ; <u>Varuna</u>	LAGOONAL fish prawns crabs
RIVERMOUTH	open	absent	river flow	potamonic or fresh (~ 0, 5‰)	<u>Clarias</u> ; <u>Barbus</u> <u>Macrobrachium petersii</u> <u>Potamonautes</u>	RIVERINE fish prawns crabs

* after the "Venice System" (Spada, 1959)

LAGOON (functional)

Zinkwasi, Nonoti, Mdlotane, Seteni, Mloti, Mhlanga, Sipingo, Mbookodweni, Manzimtoti, Little Manzimtoti, Msimbazi, uMgababa, Ngane, Mahlongwana, Mahlongwa, Mzinto, Miesingane, Fafa, Mvuzi, Mnamfu, KwaMakosi, Mfazazana, Mhlungwa, Mhlabatshane, iNtshambili, Koshwana, Damba, Mhlangankulu, Mtentweni, Mbango, Boboyi, Zotsha, Mhlangeni, Kongweni, Uvuzana, Bilanhlolo, Mvutshini, Moizana, Kaba, Umhlangankulu, Mpenjati, Kandandlovu, Ku-boboyi.

(verging on river mouth transformation)

Mzimayi, Mkumbane

RIVER- Mvoti, Mzombe
MOUTH

Due to the lifeless condition of the Sezela, the system is unclassifiable on the basis of community structure, and is regarded as a non-functional lagoon. Until such time reliable community data is forthcoming, the Vunqu has been tentatively classified as an estuary, and the Zolwane as a lagoon, on the basis of their physical characteristics.

4.4 DISCUSSION

Until recently (Begg, 1978; Noble & Hemens, 1978) no real effort has been made in South Africa to distinguish for example, between estuaries and lagoons, as the two terms are used very loosely by most workers (Wallace, 1975; Whitfield, 1979, Day, 1981) in the belief that there is no real difference between them.

The term lagoon seems to be used most often by Day (1981) to describe a broad, shallow expanse of quiet water such as Langebaan (on the west coast of South Africa) and Richards Bay (in northern Natal); or to describe the expanded part of an open estuary such as Knysna (in the eastern Cape) and temporarily closed estuaries such as Hermanus (in the S.E. Cape). The terms 'estuary' and 'lagoon' are also used

(even in the same paragraph) to describe systems such as the Fafa and Mhlanga, and there are examples of the same system being referred to as an estuary, a vlei, rivermouth and lagoon all within the same publication (Morant & Grindley, 1982).

Most people find this confusing to say the least (Reddering, 1980) especially as sandbar development opposite the mouths of rivers along high energy coastlines is widely recognized (Day, 1981) and for this reason 17,9% of the African coastline was classified as lagoonal by Cromwell (Barnes, 1980:1). However, Day (pers.comm.) sees little point in rigidly defining the word 'lagoon' but sees merit in incorporating those systems blocked by wave-deposited sediments into an all encompassing definition of the word 'estuary' by amending Cameron and Pritchard's definition to read "... an estuary is a partially enclosed coastal body of water which is either permanently or periodically open to the sea, and within which there is a measurable variation of salinity due to the mixing of seawater with freshwater derived from land drainage." (Day, 1980; Anon., 1983).

This would be an acceptable compromise were it not for the results of this study, and the well known fact that the utilization of closed systems by marine organisms is reduced (Scott *et al.*, 1952; Hodgkin, 1980; Branch & Branch, 1981). Thus, by including closed systems into the definition of an estuary, the popular concept of estuaries being of indispensable value to a great variety of marine organisms (Douglas & Stroud, 1971; Heydorn, 1973; Wallace, 1975) would cease to have any validity if both "permanently and periodically open" systems were called the same thing.

For example, the clear distinction between the communities occupying the Mvuzi and the Mgeni (Fig. 10), is on analysis, due to the fact that the former is normally closed and the latter is normally open, and because the biota in each have synthesized the environmental variables involved into one common response.

Because the determinants which dictate whether any "partially enclosed coastal body of water" remains open or closed to the sea are physical forces (namely fluvial, tidal and wave-induced processes) the classifications adopted by coastal geomorphologists (Jennings & Bird, 1967; Orme, 1974; Lankford, 1977; Moes, 1979; Reddering & Esterhuysen, 1982) are entirely within keeping of that proposed by Cameron and Pritchard (1963), and that proposed in Table 15. Common

to them all, whether physical, chemical or biological, is the fundamental requirement of "free connection with the sea". From a biological point of view this means that the estuary in question is subjected to regular tidal exchange, and through this process marine utilization of the system is enhanced, and the nursery function of estuaries is fulfilled.

On the evidence presented in this Chapter, the results of DCA, and the information in the Appendix, it is difficult to accept that the Amahlongwana is an estuary when it has remained closed to the sea for all but 24 days of the past four years; or the Mvoti as an estuary when the salinity is consistently zero; or the Fafa when curled pondweed (Potamogeton crispus) and waterlilies grow within it; or the Mvuzi when 97% of the animals caught therein are resident species which do not require access to the sea (Fig. 23); or let alone the Sezela which is so grossly polluted that the only living organisms in it are rat-tailed maggots.

On the other hand designation of the Mgeni as an estuary is acceptable, because of its open mouth condition, dynamic salinity regime and marine-associated fauna. Of particular significance, is the fact that remarkably few of the systems surveyed on the Natal coast during the course of this study can be regarded as estuaries (sensu Cameron & Pritchard, 1963). The necessity to distinguish between estuaries, river mouths, lagoons and bays (Table 15) has nothing to do with semantics, nor is it of theoretical interest, nor is it a new concept (Barnes, 1974, 1980). On the other hand, the paucity of functional estuaries has an important bearing on the recruitment of estuarine dependent marine species (especially those of importance to man) estuarine degradation, resource evaluation and estuary conservation along our coastline (Chap. 6).

The fact that lagoons such as the Mloti and uMgababa may briefly assume estuarine characteristics whilst open, is not regarded as sufficient evidence to classify the system as a functional estuary. Barnes (1980) has stressed that lagoons are rarely completely isolated from the sea, and has recognized that there is an evolutionary sequence in habitat types in the coastal zone. These grade from semi-enclosed marine bays, through estuaries and lagoons to freshwater coastal lakes. This idea has also been expressed by Koop et al. (1983) since their studies of the Bot River in the southwestern Cape,

where, having come to recognize the signs of the system losing its identity with true estuaries, consider it to be evolving into a coastal lake. More importantly, however, Barnes recognized that through man's activities this evolutionary trend can be altered. Whilst discussing the merits of estuary classification, Siegfried (1981a) clearly envisaged the same thing when he described the continuum of variation between "...the perfect estuary at one extreme to something that is no longer an estuary at the other extreme." The results of this study (Figs 7 & 10) and the opinions of Gladson (1981) confirm these points of view.

In the Appendix and throughout this Chapter attention has been drawn repeatedly to the transformation of estuaries into river mouths (Mvoti); or systems that are on the verge of such transformation (Mpambanyoni) or threatened by transformation possibly before the turn of the century (Mkomazi) by continued infilling of the estuary basin by sand and silt (Chap.6). The process of transformation from lagoon to swamp has been witnessed (Mzimayi) as well as the process of transformation from a functional lagoon to a non-functional lagoon as a result of pollution (Sezela) and river diversion (Sipingo).

An important conclusion that can be drawn from the data presented in this Chapter is that the biota (in this case caught by a small beam trawl) do indeed synthesize whatever environmental variables are involved into one common response and consequently can be used as an indirect but effective means of classifying the variety of habitats that occur along the coastline of Natal as either rivermouths, lagoons, estuaries or bays. There also seems to be no reason why this approach cannot be adopted for the same purpose elsewhere along the South African coastline or, for that matter, have application elsewhere in the world. What is equally significant is that it is possible to go a long way towards achieving such a classification without it being essential to employ sophisticated computer facilities and ordination programs. All that is really necessary is a good 'old fashioned' ecological understanding of these coastal systems to achieve the classification proposed in Table 18. Multivariate analysis can then be used to verify the classification and refine it. These techniques help to reveal the underlying structure of the data, and facilitate detection of the dynamics and interrelationships involved within and between each system.

Finally, this study does not pretend to be a definitive work on Natal's estuaries, nor the last word on the subject of estuary classification, because it is based on the limited amount of information collected during a three year study period, and in the event of a wet cycle developing in the 1990's (Tyson & Dyer, 1978; Maud, 1980) what are lagoons today may become estuaries tomorrow. What this study does do however, is to provide an initial resource evaluation for each system, to provide a solid foundation upon which further information on any of the systems studied can be added (Chap.5), and to provide a basis upon which systems further afield (north of the Tugela and south of the Mtamvuna) can be incorporated. It also stresses the need for consistency in use of the word estuary.

CHAPTER FIVE

ESTUARY CHARACTERIZATION

INTRODUCTION

Chapter 4 deals with the interrelationships between each system and the total species complement in each was used to demonstrate these relationships. However, another use of the ordination of community data is to establish the degree of stability of each system by comparing the ordination position (or score) of each sample taken, to preceding samples from that system.

This describes the extent to which community composition varies on a temporal basis (Sect.5.1) and enables changes in community composition to be detected as a result of environmental changes. For example, these may be when closed systems open, or when floods occur. Just as the effects of natural perturbations such as these are revealed, the effects on community structure by unnatural perturbations such as pollution can also be assessed. Furthermore, changes in terms of spatial differences above and below some man-made obstruction such as a freeway (in the uMgababa for example) or a weir (as in the Mdesingane) can be demonstrated by multivariate analysis (Sect.5.2). Such techniques also enable differences between habitats within an estuary (e.g. backwaters) to be examined independently of any other within the same system.

Multivariate analysis is commonly used in pollution studies (Gauch,1982). For example, Green and Vascotto (1978) discuss the benefits of using zooplankton from 34 lakes in Ontario as a means of measuring and monitoring pollution. Arfi et al. (1981) also use ordination of zooplankton as a means of showing changes in community structure in an area off the French coast which is exposed to sewage; and Hamer and Soulsby (1980) have applied multivariate analysis to the biological monitoring of river pollution in Britain.

The data used to describe the salient features of each system (detailed in Sections 5.1-5.2) are derived from the tables which accompany the account given of the fauna of each system in the Appendix. As in the previous chapter two different inputs (abundance values versus presence/absence data) were used for the sake of comparison, but with one exception (the Manzimtoti) insufficient advantage was gained by doing so to merit duplication of the various ordinations generated. In the Manzimtoti Lagoon however, (Fig.31) the consequences of ammonia pollution seemed detectable when abundance values were used, but not so when presence/absence data were used.

In most cases the sample size (Table 3, Chap.2) was so small that very little weight could be attributed to the results. Consequently, in this chapter a selection of systems in which the data base was more adequate has been made to illustrate the extent of variation in community structure during the study period, as revealed by detrended correspondence analysis (DCA). The Mkomazi and Mgeni were chosen as two estuaries in which the data base (22 months) was more comprehensive than in any other system studied. The Zinkwasi, Mdloti, Msimbazi and Manzimtoti, were chosen as four lagoons, each of which had a 15 month data base, but differed in terms of the perturbations within each system, as well as in features such as salinity (see Appendix).

These provide an appreciation of how DCA and the community data in the Appendix are to be used to provide a basis upon which the future condition of estuarine systems in Natal can be measured, (an objective of the study stated in Chapter 1).

In each of the following figures the axes have been left unlabelled because the 'samples scores' derived by DCA are of no further assistance beyond specifying the position of each sample in the ordination. The numbers adjacent to each point in the accompanying graphs represent the month and year (0481 = April 1981) in which the survey was conducted. For convenience, an arbitrary probability envelope within the ordination has been defined by ordination space partitioning, and is referred to periodically as the 'core area' within the ordination space.

5.1 TEMPORAL CHARACTERIZATION

5.1.1 Mkomazi Estuary

Ordination of the community data from the Mkomazi (Fig.24) suggests that during the 22 month study period some fairly radical changes in community structure occurred because of the comparatively wide 'scatter' of the points representing each sample in the ordination diagram. The data are derived from Table 19.

Of particular significance is the influence of river flow during the study period, because if the flow data (Fig.25) are referred to, it is clear that on those two months that the highest river flows were experienced (60 cumecs being exceeded in February & March 1981) that the corresponding sample positions in Figure 24 were outlying of the core area (or 'norm'). Although it was impossible to establish accurately what species were present in the main body of the estuary because of the high current velocity, it seems safe to say that the Mkomazi was temporarily transformed into a river mouth on these occasions. Certainly salinity throughout the system was reduced to zero (Table 46, in the Appendix) and from the results of netting in backwaters, species diversity had also been greatly diminished (Table 19). High flows were also recorded in February and October of 1980 (Fig. 25), but on these occasions community structure in the estuary for some reason, remained unaffected.

A major change occurred when low flows were experienced, as in July and September 1980. On these occasions tidal influences dominated the system instead of river influences, and so the community structure within the system was influenced to a more noticeable degree by species of marine origin than by species of riverine origin. Although not reflected in Table 19 this change, to my mind, is best illustrated by the trawl recovery of young octopus (Octopus vulgaris) from within the estuary in September 1980 (see Appendix). There are also occasions when low flows do not coincide with such radical changes in community structure (Fig. 25). This may be due to

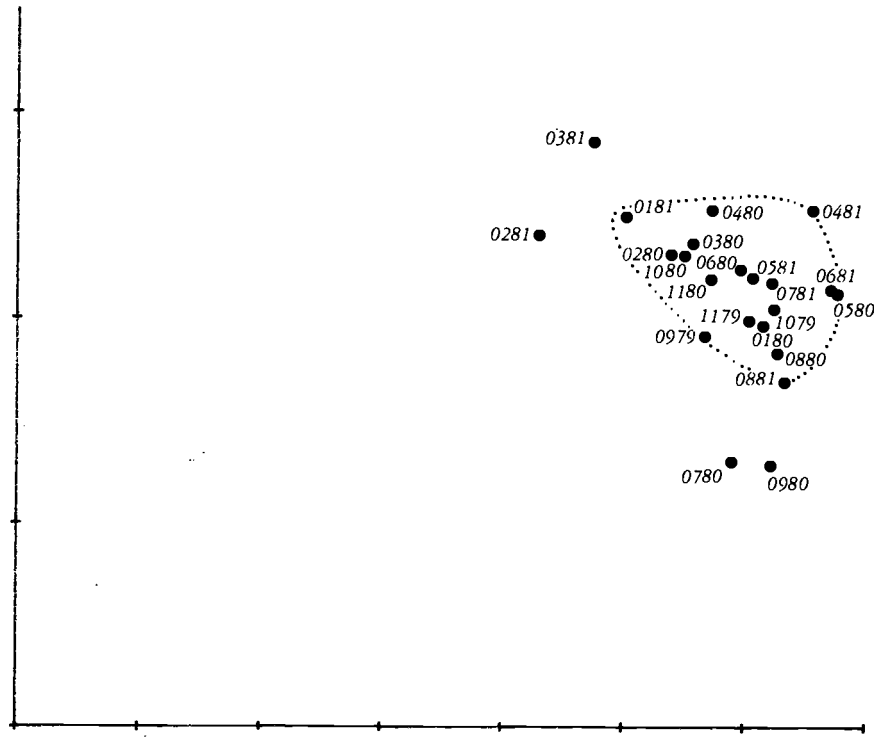

Fig.24 Temporal variation in community structure of the Mkomazi Estuary after ordination of the data in Table 19. The core area is defined by a dotted line (0381=March 1981, etc)

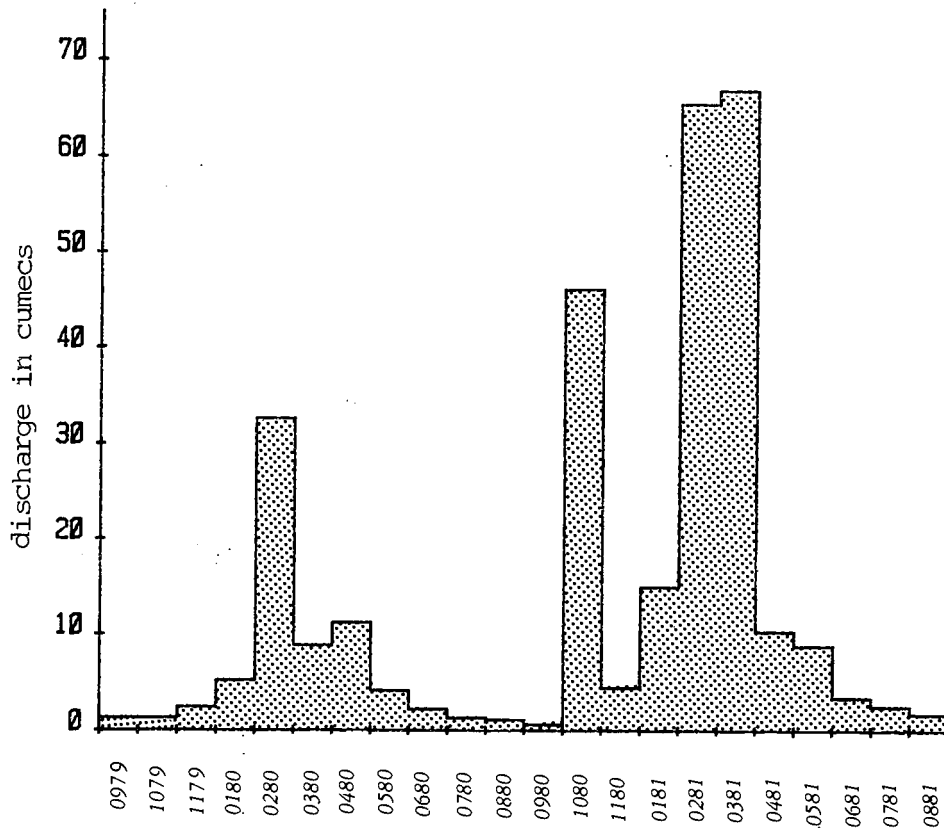

Fig.25 Flow of the Mkomazi River (from records maintained by SAICCOR, see Appendix) on those occasions the estuary was being sampled. The dates (0580 = May 1980) therefore correspond with those in Fig.24.

differing states of the tide during the sampling period, however, before speculating further it would be advantageous to examine these data in three dimensions, as in Figure 11 in Chapter 4.

Both high flows and low flows are nevertheless perturbations of the system that are natural, and revealed by changes in community structure. It will be apparent that because of the matrix format in which the data are presented, Table 19 is not easily used to establish what species changes occurred on either of these occasions, whereas, when the same data are presented in the form of an ordination, the visual impact helps enormously in ascertaining the extent to which the samples differed from each other. If Table 19 is used to establish which species caused these differences, the task is tedious and difficult, whereas by DCA it is simple and effective, as the technique is sensitive to community responses rather than changes in single species.

It is presumed therefore that as and when future samples are taken from the Mkomazi, and depending on the circumstances at the time, that these could be expected to fall within that region of the ordination defined as the core area in Figure 24. If this is not the case, it also seems likely that the reason why the data do not conform can also be established. It follows therefore, that by defining the character of the Mkomazi on a temporal basis, ordination of community data appears to be a means by which a surveillance of the system can be maintained in the future.

5.1.2. Mgeni Estuary

Ordination of the data contained in Table 20 of the Appendix suggests that during the same study period (Sep 1979 - Aug 1981) variation in community structure within the Mgeni Estuary (Fig.26) was not as great as that in the Mkomazi. In fact, the data are exceptional in that they remain confined to a relatively small

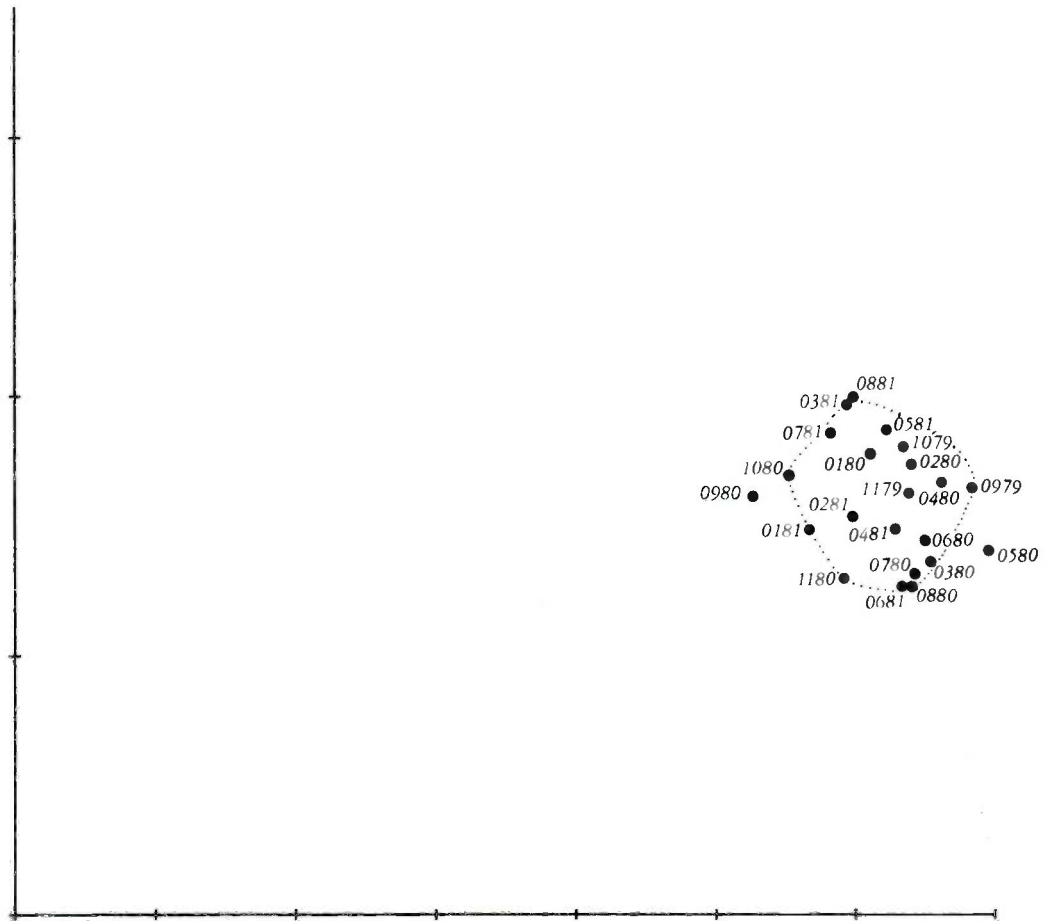

Fig.25 Temporal variation in community structure of the Mgeni Estuary after ordination of the data in Table 20 (Appendix). The core area is defined by a dotted line (0481 = April 1981, etc).

area of the ordination, and irrespective of the variation that occurred in factors such as salinity and temperature (Table 19 in the Appendix).

This stability is probably a reflection of the physical stability of the system throughout this time, although a minor flood was experienced in September 1980. This may account for the marginally outlying position of the corresponding sample position (0980) in the ordination. On this occasion, species such as Leiognathus equulus, Oligolepis acutipennis and Scylla serrata (which are normally present in the system) were absent (Table 20 in the Appendix). Judging from its proximity to the above mentioned point in the ordination, it is suggested that the effects of these floods were still detectable in October 1980. No explanation can be offered however for the outlying position of the samples taken in May 1980.

An event which caused much concern during the study period was spoil disposal by dredgers. This activity commenced above the estuary in March 1981 (see Appendix) and continued until after the end of the study period. A drastic reduction in water transparency was measured downstream, as well as the flocculation of a considerable volume of suspended sediment. Despite despoilation of the estuary, with specific reference to its recreational value, ordination of the community data gathered during this period suggests that no major effects were felt by the estuarine organisms occupying the system. This assumption may be erroneous because trawling was exceptionally difficult under the circumstances that prevailed, and the results from backwater areas (such as Beachwood, which remained unaffected by events in the main body of the estuary) were included in the analysis. However, on the basis of the data analysed it would be even more dangerous to assume that environmental damage was in fact detectable in the estuary. In this particular case therefore, it would seem that multi-variate analysis is a valuable tool in arriving at an unbiased decision about the environmental consequences of spoil disposal.

5.1.3 Zinkwasi Lagoon

Whilst ordination of the community data from the Zinkwasi Lagoon (Fig.27) greatly facilitates the detection of those occasions during the study period when community structure in the system appeared to differ from the norm, no convincing explanation can be found to account for all these occurrences. The data are derived from Table 2 in the Appendix.

Although the lagoon was open in September 1979, it was also open in January 1981 (Table 1 in the Appendix) and whilst the salinity was exceptionally high (29‰) in June 1980, it was just as high (30,7‰) in January 1980. The outlying position of the April 1980 samples seems attributable to the fact that on this occasion only seven species were taken in the system (Table 2 in the Appendix), i.e. an occasion when the lowest diversity was recorded during the study period, but no particular environmental influence can be traced to account for this situation.

Whilst these limitations may cast some doubt on the value of the ordination of community data, the fact remains that compared with Table 1 in the Appendix) Figure 27 begins to define the character of the Zinkwasi, as well as a region in the ordination in which further data from the system can be expected to coincide. Whatever the reasons may be, this result would at least satisfy the investigator that the Zinkwasi Lagoon still supports the same community that it has been shown to maintain thus far.

5.1.4 Mdloti Lagoon

Apart from the data within the core area of Figure 28, the structure of the community data from the Mdloti Lagoon is even more divergent than that from the Zinkwasi. The data are derived from Table 16 in the Appendix.

One explanation for this is artificial breaching of the lagoon mouth because during the study period the bar was breached

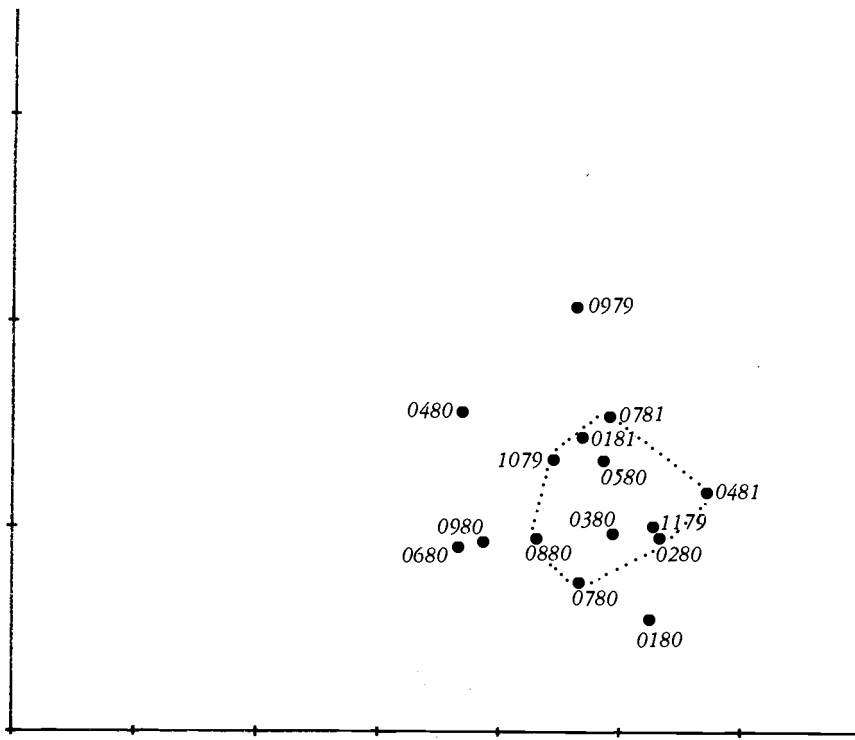

Fig.27 Temporal variation in community structure of the Zinkwasi Lagoon after ordination of the data in Table 2 (Appendix). The core area is defined by a dotted line. (0979 = September 1979 etc.)

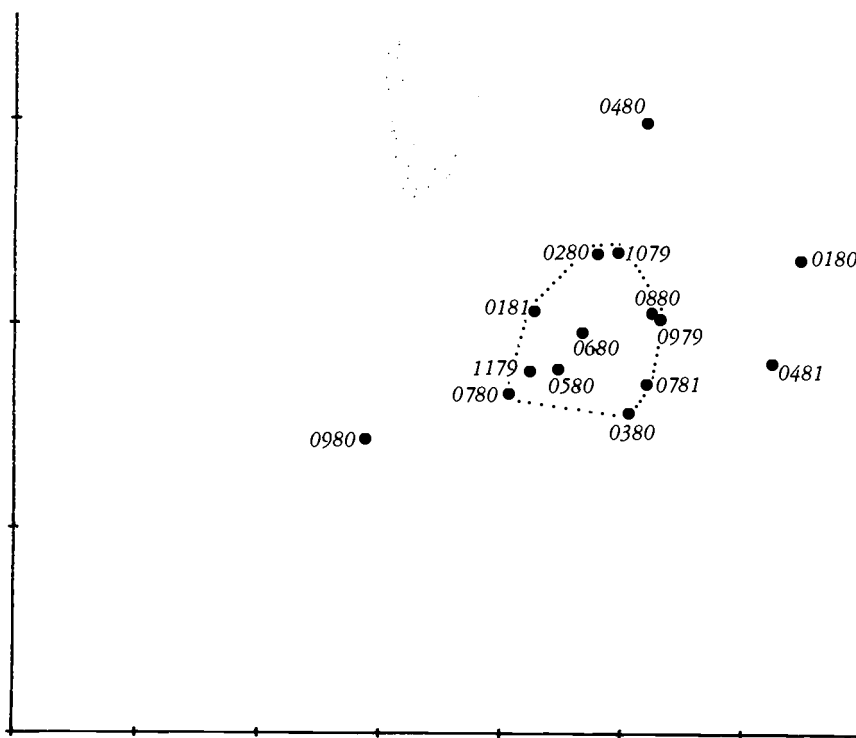

Fig.28 Temporal variation in community structure of the Mloti Lagoon after ordination of the data in Table 16 (Appendix). The core area is defined by a dotted line. (0480 = April 1980 etc).

artificially on 16 occasions (Fig.14, in the Appendix) to prevent the flooding of sugarcane adjacent to the system. The effects on lagoonal productivity are discussed by Whitfield (1980) and Blaber et al. (1982), but artificial breaching of the bar naturally increases the periodicity of contact with the sea and hence permits utilization of the system by species that are more normally associated with open systems. This gives rise to a more heterogeneous community and hence greater variability in community structure.

On the other hand, the Mdloti is stressed in various other ways. The instability of the system from a hydrological point of view is remarked upon by NRIO (1982) and pollution of the lagoon by dieldrin has recently been disclosed (Blaber et al. ,1982). It is tempting to suggest that the presence of only two species in the system in January and April 1980 (Table 16 in the Appendix) could be the result of a pollution event, but when as few as three species (in August 1981) and four species (in September 1979) were present, the position of these samples in the ordination associate within the 'core area'.

Another difficulty in interpreting these data is sample heterogeneity because, as detailed in Table 5 (Chap.2), water level can influence the trawl results to a marked degree. The fact that other than in March and August 1980 the sample position in the ordination was outlying of the norm whenever the water level was high (Table 20) is a strong indication of sampling imprecision. If this is the case, these samples could be justifiably ignored.

5.1.5 Msimbazi Lagoon

After 15 visits to the Msimbazi Lagoon during the period September 1979 to July 1981 (Table 40 in the Appendix) the structure of the data in Figure 29 suggests that the prevailing mouth condition (Fig. 37 in the Appendix) plays an important part in determining the ecological character of this lagoon.

During 1980 the mouth remained closed for 361 days (99% of the year) and for this reason it seems likely that the positions of the

Table 20. The variation in water level in the Mlleti Lagoon on those occasions the system was sampled during the period September 1979 to July 1981. Arrows denote those instances when the community structure was outlying of the 'core area' defined in Figure 28. (0979 = Sep.1979)

Date	Water level
0979	normal
1079	low
1179	normal
0180	high ←
0280	normal
0380	high
0480	high ←
0580	low
0680	normal
0780	low
0880	high
0980	high ←
0181	low
0481	high ←
0781	normal

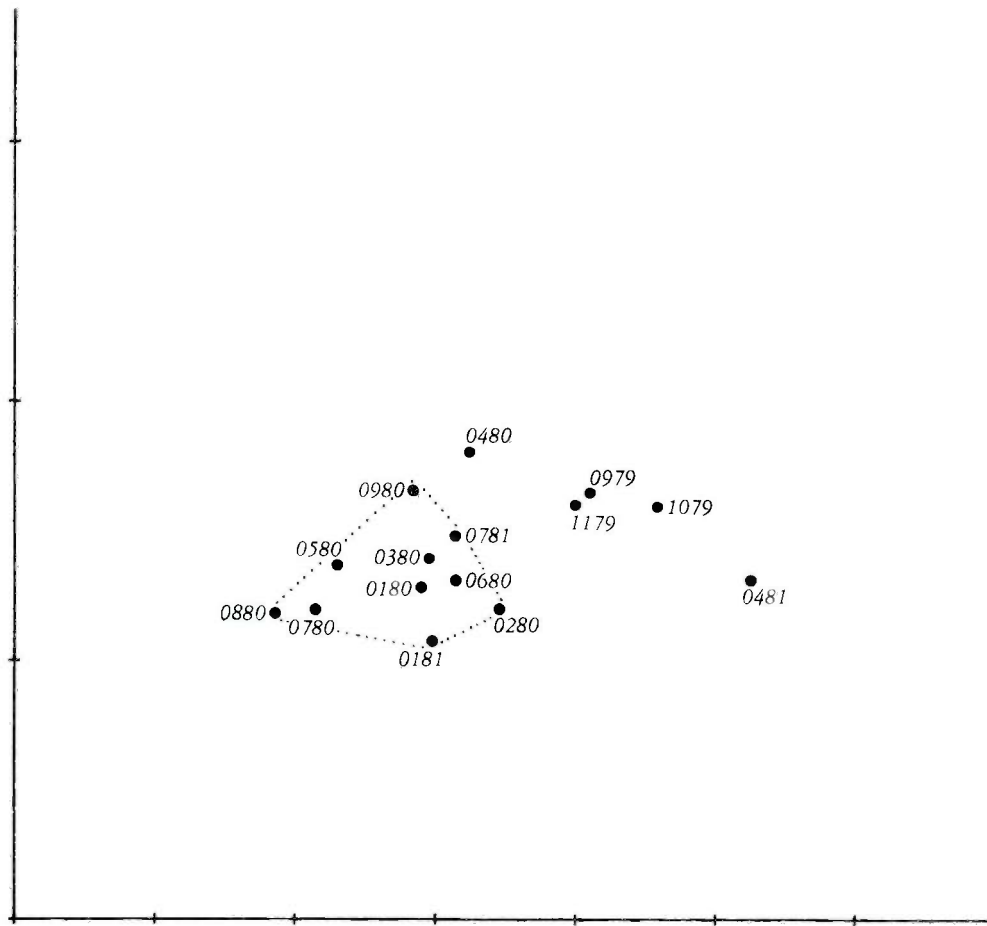

Fig.29 Temporal variation in community structure of the Msimbazi Lagoon after ordination of the data in Table 37 (Appendix). The core area is defined by a dotted line. (0280 = February 1980 etc).

nine samples taken during 1980 all fall within or close to the 'core area' of the ordination diagram. Some of the scatter during 1980, especially during the winter months, could be attributable to interference with the trawl by filamentous algae (Chaetomorpha sp.) (see Plate 23, in the Appendix).

The dissimilarity of the 1979 samples seems attributable to a 16-day period of contact with the sea in August 1979, after which time various estuary-associated organisms (Tylodiplax blephariskios, Syngnathus djarong and Penaeus japonicus) made a brief appearance in the system (Table 40 in the Appendix). The extreme dissimilarity of the samples taken in April 1981 may have been due to overwash of the bar during the equinoctial tides in March, since it is the only occasion when Penaeus indicus, Valamugil buchanani and Arothron immaculatus appeared in the system.

Throughout the study period freeway construction was underway at the head of the Msimbazi Lagoon, and the system was modified in the manner described by Begg (1978). However, it should be noted that ordination of the community data from the Msimbazi showed none of the stress symptoms that were revealed by the uMqababa for example where, as a direct result of freeway construction, the community structure was markedly affected (Fig.33). From this and other evidence given in the Appendix, it can be assumed that the resilience of the Msimbazi was far greater than imagined, since the system appeared to have no difficulty in tolerating the changes imposed.

5.1.6 Manzimtoti Lagoon

The data contained in Table 31 of the Appendix was used to determine what changes in community structure occurred in the Manzimtoti Lagoon during the study period. Ordination of these data (Fig. 30) suggested that little variation occurred, as the interpoint distances between each sample were so slight that all the data fell within a relatively distinct core area.

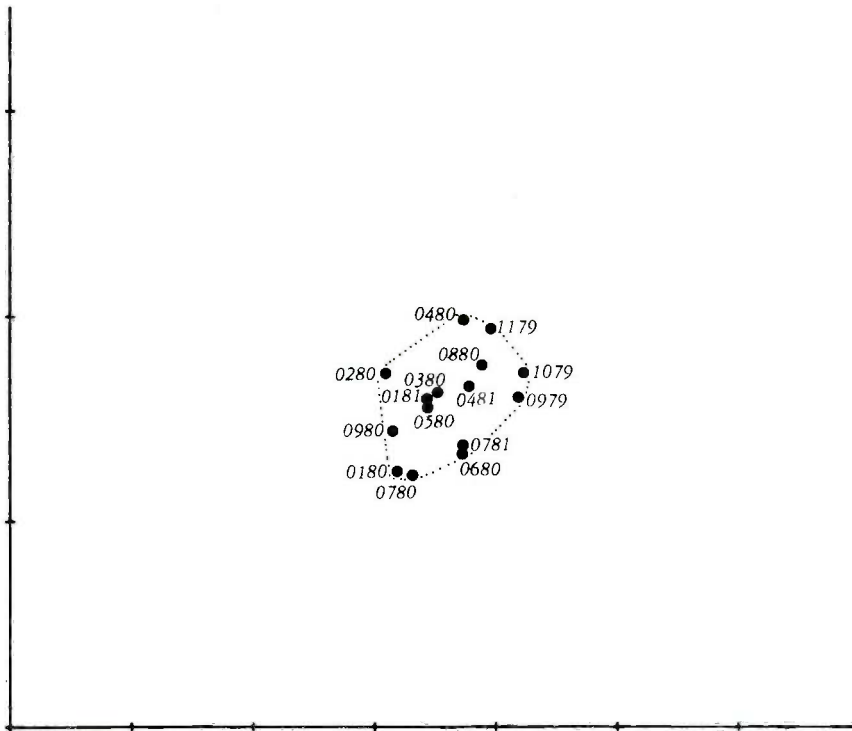

Fig.30 Temporal variation in community structure of the Manzimtoti Lagoon after ordination of the data in Table 31 (Appendix). The core area is defined by a dotted line (0580 = May 1980 etc.)

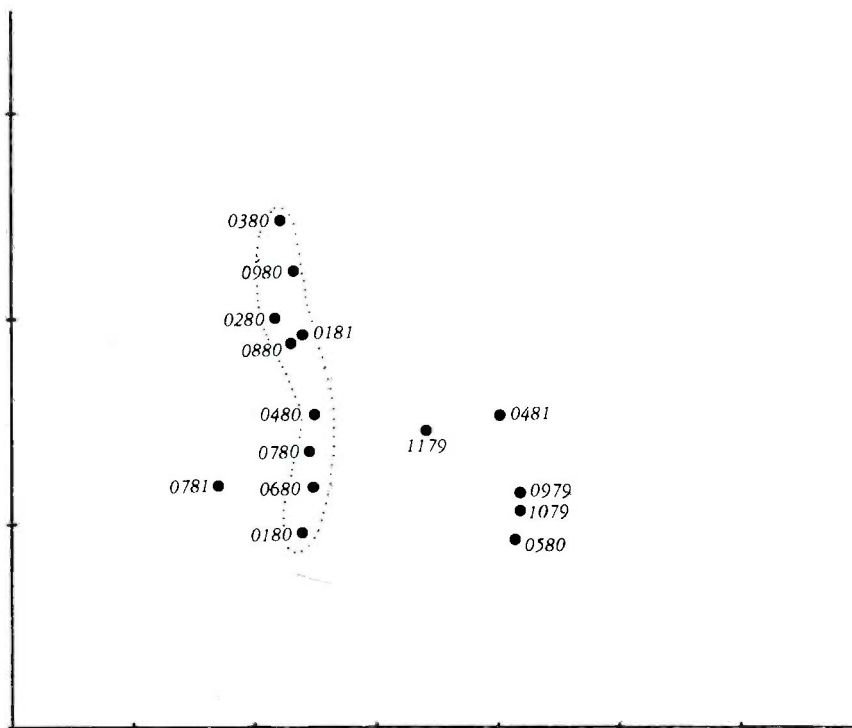

Fig.31 Temporal variation in community structure of the Manzimtoti Lagoon after ordination of the data in Table 21. The core area is defined by a dotted line (0580 = May 1980 etc.).

This was not the case when the abundance data expressed in Table 21 was used, as a configuration of points rather different to anything yet seen was obtained (Fig.31).

The major difference is the linear relationship of the nine points comprising the core area (0380, 0980, 0181, 0280, 0880, 0480, 0780, 0680 and 0180). These can be correlated with a decrease in the relative abundance of Oreochromis mossambicus (Table 21) for the abundance of this species ranged from 85,3% of the catch in March 1980 to 19,1% in January 1980. Furthermore, between these two points there is a steady transition from 68,1% to 63,4% to 54,7% to 59,4% to 43,7% to 36,4% and to 28,4% respectively.

What is equally clear is that whilst similar to each other four of the sample positions in the ordination (0481, 0979, 1079 and 0580) are noticeably different from any of the samples mentioned in the above paragraph. It could be coincidental, but pollution of the Manzimtoti by ammonia was an established fact in May 1980 (see Appendix) and it seems probable that on each of the other occasions (0979, 1079 and 0481) ammonia pollution unknowingly occurred as well. For example, the abnormally high levels of dissolved oxygen experienced in the lagoon on these occasions (Table 30 in the Appendix), could be explained by algal blooms in response to the availability of nitrogen. The outlying position of the November 1979 samples (1179) could be interpreted in the same way, although the pollution caused may not have been as severe.

On the other hand, the community responses mentioned need not be related to pollution at all, because other than in May 1980, an association between the remaining samples and an increase in the abundance of Metapenaeus monoceros is detectable from the figures in Table 21. Furthermore, if the same data are used in a presence or absence format (Fig. 30), no trends similar to those above are revealed.

Table 21. The relative abundance of the species caught in 86 trawl samples from the Manzimtoti Lagoon expressed as a percentage of the total catch on each trip.

	1979									1980									1981		
	10.9	9.10	9.11	14.1	15.2	12.3	9.4	5.5	10.6	16.7	13.8	11.9	13.1	7.4	14.7						
FISH																					
<u>Gilchristella aestuarius</u>	3,7	23,5	29,1	75,7	26,7	4,4	47,3	42,4	49,2	38,5	32,5	11,4	19,2	11,5	40,4						
<u>Solea bleekeri</u>	11,1	11,7	8,3		2,8	0,7	5,4	2,0			0,5		0,5		1,1						
<u>Terapon jarbua</u>			8,3	1,7	1,4	0,7				1,4	1,9				1,1						
<u>Gerres rappi</u>				2,3		3,7	0,9	9,1	16,4	21,0	3,3		0,5		2,2						
<u>Ambassis productus</u>								1,0	1,5		2,3										
<u>Pomadasys commersonni</u>		2,9										11,4	17,7	1,9	1,1						
<u>Acanthopagrus berda</u>												2,3		1,9							
<u>Rhabdosargus holubi</u>	14,8					2,2	0,9				0,9	2,3									
<u>R. sarba</u>																					
<u>Mugil cephalus</u>																					
<u>Liza macrolepis</u>															0,5						
<u>L. richardsoni</u>				0,6						1,4			0,5								
<u>Psammogobius knysnaensis</u>				0,6																	
<u>Glossogobius giurus</u>			8,3		5,6	1,5		1,0	1,5	0,7	0,5	2,3	3,9	1,9	37,0						
<u>Oligolepis acutipennis</u>											0,5			1,9	1,1						
<u>Eleotris fusca</u>	3,7																				
<u>Oreochromis mossambicus</u>	11,1	11,7	25,0	19,1	63,4	85,3	43,7	40,4	28,4	36,4	59,4	68,1	54,7	32,7	11,1						
<u>Tilapia rendalli</u>												2,3	0,5								
PRAWNS																					
<u>Penaeus monodon</u>	7,4									1,5											
<u>Metapenaeus monoceros</u>	18,5	29,4	4,2							1,5				48,0	3,4						
<u>Macrobrachium equidens</u>			8,3				0,9	4,0		0,7	0,5		1,0								
<u>Palaemon concinnus</u>																					
CRABS																					
<u>Varuna litterata</u>						1,5															
<u>Sesarma catentata</u>	3,7																				
<u>Scylla serrata</u>	25,9	17,6	8,3				0,9						1,0								

5.2 SPATIAL CHARACTERIZATION

The repercussions on community structure of natural perturbations (such as floods in the Mkomazi) and unnatural perturbations (such as pollution from ammonia in the Manzimtoti) have been examined in Section 5.1, but in certain cases effects such as these may be confined to specific regions of an estuary or lagoon. By analysing the biological data from these regions independently of those from the rest of the estuary, spatial differences in community composition can be examined by multivariate analysis. To illustrate this three examples are given below.

5.2.1 The effects of weir construction on the Mdesingane

Many years ago a weir was built across the lower reaches of the Mdesingane to provide water for the residents of Bazley Beach (see Vol.41). This has since been abandoned, but its effect on the community structure of the system are still evident.

By analysing those samples taken from below the weir separately from those taken from above the weir (Table 22), the impact of this structure can be seen by examining the corresponding sample positions in Figure 32 for February, May and August 1982. The community structure in the two regions of the lagoon is distinctly different, particularly as a greater number of estuary-associated species occur below the weir. Above it, however, the community is more freshwater associated .

5.2.2 The effects of freeway construction on the uMgababa

Construction of the freeway over the uMgababa commenced in 1978 and for several years the upper reaches of the uMgababa were cut off from the lower reaches, whilst the embankments were being built, and the morphometry of the system altered to accommodate the bridge site (see Vol.41).

Samples taken above the freeway were analysed separately from

Table 22. The frequency of occurrence and distribution of species caught in 12 trawl samples from the Mdesingane Lagoon over the period February to August 1982.

	Above Weir			Below Weir		
	1982			1982		
	02	05	08	02	05	08
FISH						
<u>Gilchristella aestuarius</u>		*	*	*		
<u>Solea bleekeri</u>				*		
<u>Terapon jarbua</u>				*		
<u>Monodactylus falciformis</u>				*		
<u>Gerres rappi</u>				*		
<u>Rhabdosargus holubi</u>				*		
<u>Mugil cephalus</u>				*		
<u>Valamugil buchanani</u>					*	
<u>Liza dumerili</u>				*		
<u>L. macrolepis</u>				*	*	
<u>Myxus capensis</u>		*			*	*
<u>Psammogobius knysnaensis</u>					*	
<u>Glossogobius giurus</u>	*	*	*	*	*	*
<u>Oligolepis acutipennis</u>				*		
<u>Caffrogobius natalensis</u>				*		
<u>Amblyrhynchotes honckenii</u>						*
<u>Barbus viviparus</u>		*	*			
<u>Oreochromis mossambicus</u>	*	*	*			
PRAWNS						
<u>Caridina nilotica</u>				*		
<u>Macrobrachium equidens</u>		*				
CRABS						
<u>Rhyncoplax bovis</u>						*
<u>Varuna litterata</u>	*					*

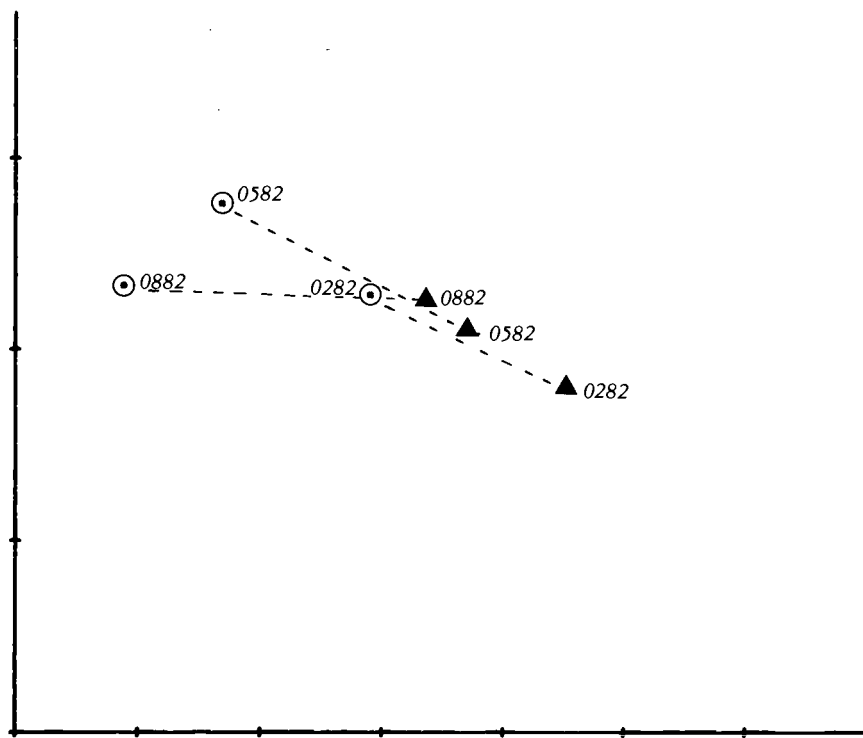

Fig.32 Differences in community structure above the weir (⊙) and below the weir (▲) in the Mdesingane Lagoon. Corresponding samples are interconnected by a broken line (0282 = February 1982 etc).

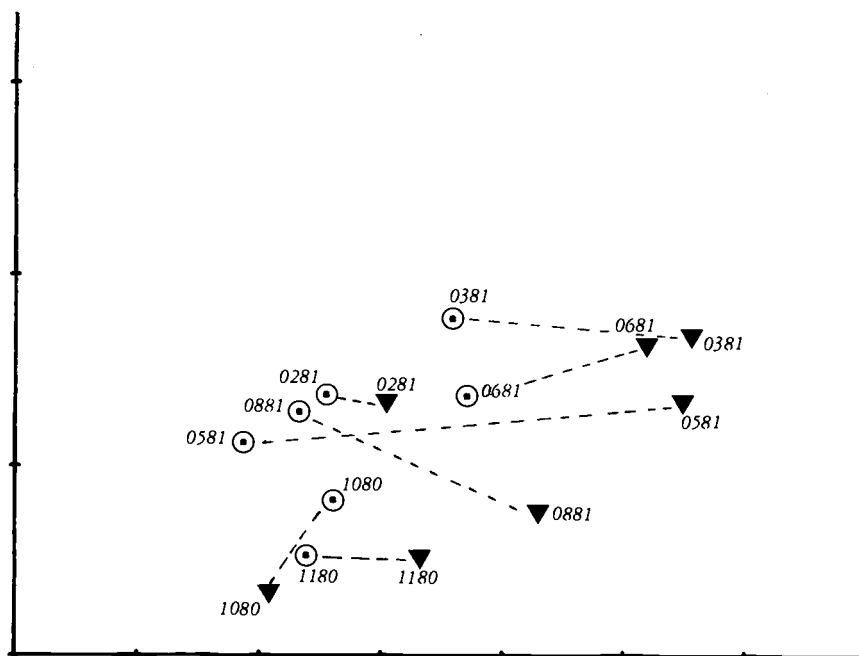

Fig. 33 Differences in community structure above the freeway (⊙) and below the freeway (▼) in the uMgababa Lagoon. Corresponding samples are interconnected by a broken line (0281 = February 1981 etc.)

those taken from below (Table 23) and the results after ordination of these data are expressed in Figure 33. Other than in February 1981 when the mouth had opened after heavy rain and the water body was homogeneous, the different community structure above and below the freeway is clearly apparent from the widely separated corresponding samples in the ordination. The differences in salinity above and below the freeway are commented on in the Appendix.

Until completion of the diversion in November 1982, the effect of the freeway was to alter circulation in the system and to restrict animal movement between the upper and lower reaches. This accounts for the different positions that the samples taken above the freeway occupy in the ordination, in comparison to those taken below the freeway, with specific reference to March, May, June and August 1981.

As the lagoon remained closed throughout 1980 spatial differences in community structure above and below the freeway were not significant. This is confirmed by the short interpoint distances between corresponding samples taken in October and November of that year (Fig. 33).

5.2.3 Differences in community structure within a backwater of the Mkomazi Estuary

Because of the 'backwater concept' discussed at greater length in Chapter 6, it seemed desirable to separate the data specific to a backwater of the Mkomazi (called the Impisini Inlet) from that pertaining to the main body of the estuary (Table 24), since the Impisini was clearly a different habitat within the estuary and subjected to different stresses. For example, life in the Impisini Inlet seemed unaffected by the floodwaters that periodically flushed out the estuary (Fig.24) but on the other hand it was vulnerable to pollution from a dump site within its own drainage basin (Fig.44, in the Appendix). This was more of local significance however, than general significance to the estuary.

Table 23. The frequency of occurrence and distribution of the species caught in 58 trawl samples from the uMgababa Lagoon.

	Above freeway						Below freeway							
	1980		1981				1980		1981					
	10	11	02	03	05	06	08	10	11	02	03	05	06	08
FISH														
<u>Gilchristella aestuarius</u>	*	*	*	*	*		*	*	*	*		*		*
<u>Bothus pantherinus</u>												*		
<u>Solea bleekeri</u>										*		*	*	
<u>Terapon jarbua</u>											*			
<u>Lobotes surinamensis</u>											*			
<u>Caranx sexfasciatus</u>				*							*	*		
<u>Monodactylus falciformis</u>					*			*	*		*	*		
<u>M. argenteus</u>								*						
<u>Leiognathus equulus</u>											*	*	*	*
<u>Gerres rappi</u>											*			
<u>Ambassis productus</u>	*	*		*	*	*				*		*	*	
<u>Pomadasys hasta</u>												*		
<u>P. multimaculatum</u>											*			
<u>P. commersoni</u>	*			*				*	*	*				
<u>Rhabdosargus holubi</u>								*	*	*	*	*	*	
<u>R. sarba</u>								*					*	
<u>Valamugil cunnesius</u>											*			
<u>V. buchani</u>											*			
<u>Psammogobius knysnaensis</u>	*	*	*			*		*	*		*			*
<u>Glossogobius giurus</u>	*		*	*	*	*	*	*	*	*	*	*	*	*
<u>Oligolepis acutipennis</u>											*	*	*	
<u>Croilia mossambica</u>	*													
<u>Redigobius dewaali</u>							*							
<u>Eleotris fusca</u>											*		*	
<u>Thyrsoidea macrura</u>														*
<u>Amblyrhynchotes honckenii</u>													*	
<u>Arothron immaculatus</u>											*	*		
<u>Oreochromis mossambicus</u>	*		*	*	*	*	*	*	*	*	*	*	*	*
PRAWNS														
<u>Penaeus monodon</u>						*					*	*	*	
<u>P. indicus</u>											*	*	*	*
<u>P. japonicus</u>											*			
<u>Metapenaeus monoceros</u>						*	*				*	*		
<u>Macrobrachium equidens</u>				*		*					*	*	*	
<u>Palaemon concinnus</u>			*	*						*	*			
<u>P. pacificus</u>													*	
CRABS														
<u>Hymenosoma orbiculare</u>													*	
<u>Rhyncoplax bovis</u>	*	*	*	*	*	*	*	*	*	*	*	*		*
<u>Varuna litterata</u>													*	
<u>Scylla serrata</u>											*			

The ordinations generated as a result of this analysis are presented in Figure 34. Of immediate interest, is the fact that despite thirty three species being particular to the main body of the estuary (Table 24), the data from the Impisini did not occupy a region of the ordination very different to that occupied by the data from the Mkomazi itself. This is largely due to the thirty two species the two habitats share in common. Confirmation of this is forthcoming when the data presented in Figure 34b (from which the Impisini results have been removed), are compared to those in Figure 24 (Sect.5.1), which include the Impisini results. The structure of the data in both cases are similar.

If corresponding sample positions are compared, it is equally clear that at certain times community structure in the two habitats both differs (e.g. 0780, 0980) and corresponds (e.g. 0380). Another feature of Figure 34 is that the community structure of the Impisini is really no more stable than that in the Mkomazi, despite the latter being influenced to a greater extent by mass movements of water such as river flow and tidal exchange. Another point, is that pollution events in the Impisini (as in Feb. 1981 when oxygen levels dropped to 0,6 mg ℓ^{-1}) (Table 46, in the Appendix) were not revealed by changes in community structure any more significant than on those occasions when pollution did not occur (e.g. 0580).

5.3 DISCUSSION

Although one of the limitations of the present study was the sparseness of the data collected from some of the systems studied (Table 3, Chap.2), the results of individually characterizing certain systems where these data are adequate on the basis of temporal and spatial differences has led to two important conclusions. Both are fundamental to the achievement of the third objective of this study which, as specified in Chapter 1, is the need "to provide a basis upon which the future condition of estuarine systems in Natal can be measured".

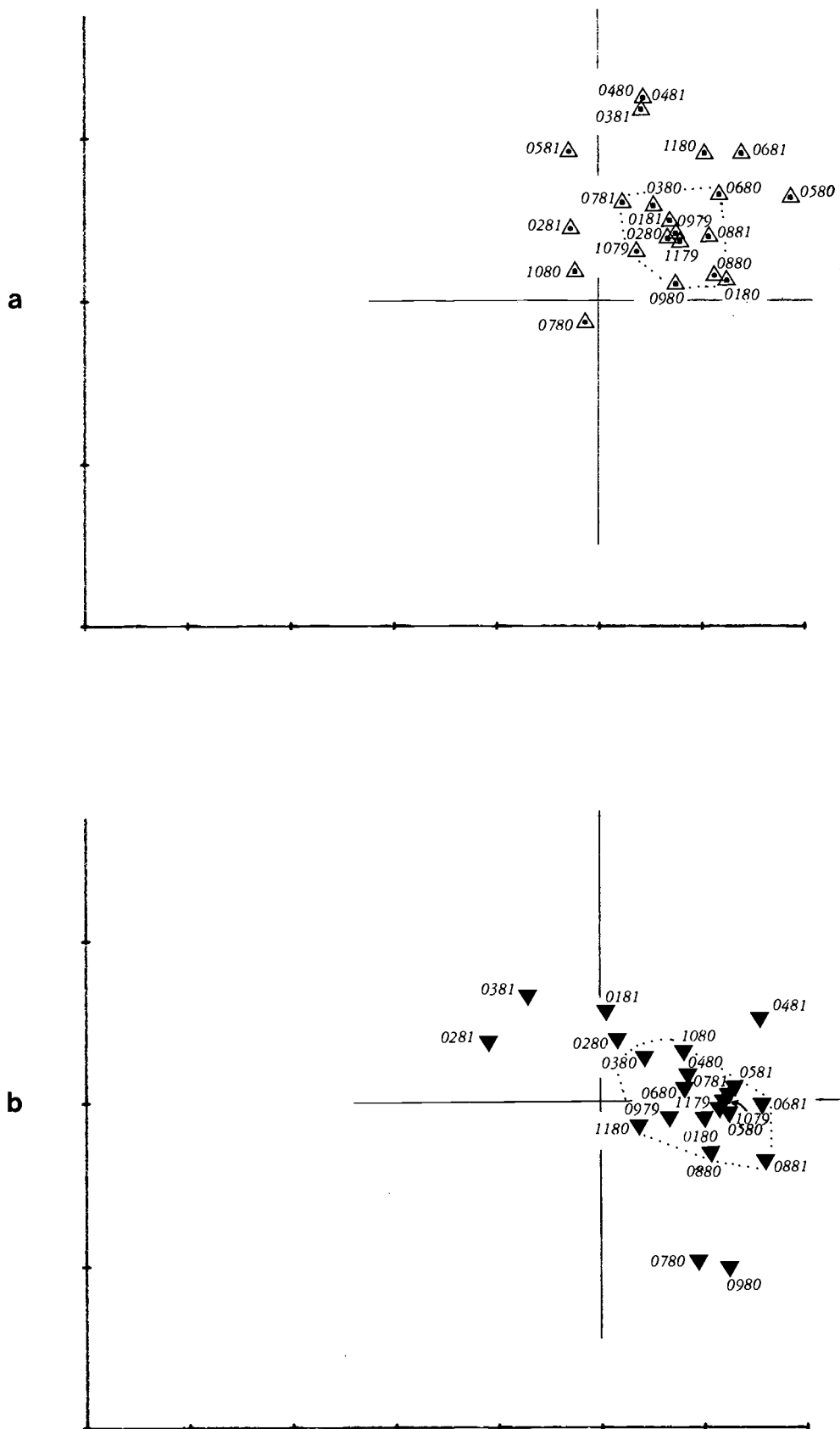

Fig.34 Differences in community structure within the Impisini Inlet (a) a backwater of the Mkomazi Estuary, and the Mkomazi itself (b). For the sake of comparison, the solid lines within the ordination act as reference points. Core areas are defined by a dotted line. (0281 = February 1981).

The first of these conclusions is that this objective does appear attainable, because on the basis of the results presented in this chapter, each system lends itself to characterization, using detrended correspondence analysis.

The second conclusion is that this is only possible because of the community composition within each system and the manner in which that community is able to synthesize whatever environmental variables prevail into one common response (see Fig. 8, Chap.4).

Generally speaking, one of the most remarkable features of the data collected is the similar 'sample scores' that can be derived by ordination of the community data after each survey is completed. Even where the data are sparse, these still serve as the beginnings of a system whereby the community structure of each estuary, lagoon or river mouth in Natal can be defined. Obviously the more samples available the better, because definition of community structure becomes increasingly apparent.

With much regard for the warning of Hedgpeth (1967) that "... fancy black boxes are not better than the watcher of the box" it is nevertheless envisaged that providing the sampling method remains consistent, the ecological character of each system studied can be defined and steadily improved upon in the future. This will be achieved by repeatedly surveying each system in the manner described in Chapter 2, as and when any opportunity arises. With the aid of a computer, two files for each system could be created, one for storage of the raw data and another for storage of those data required for ordination. After each survey a plot of the most recent results relative to the others could be produced, to judge (immediately if necessary) whether the community structure in that system has or has not altered in the interim. This period of time could be the following week (after a pollution event or flood), the following month, season or year. In each case it would be possible to obtain an ordination of each new sample, to compare with the previous ones. In this way a 'listening watch' on each coastal system in the province could be effectively maintained. The prospect of impact assessment also appears attractive, particularly as this is normally required at short notice, and because more often than not the baseline data required for such an assessment are lacking.

The format of the input data is a variable which requires further investigation, because two different results can be achieved when abundance values for example are used instead of presence/absence data. However, it is perfectly feasible to use both as a matter of course, which would function as a 'double check' on interpretation and characterization of community structure.

Bertine et al. (1979) and Livingston (1979) are of the opinion that no bioassay can fully evaluate estuary responses to pollution, and that indicator species are "clumsy tools" to measure the biological health of estuaries. In the light of certain of the difficulties in interpretation I would agree, and accept that there are several potential weaknesses in the strategy I have outlined. One is the fact that the monitoring system, as envisaged, depends entirely on a beam trawl being used as the sampling gear. To a far lesser extent, it also depends upon the skill of the operator, because this need not necessarily be the same person. Another problem is that monitoring does not necessarily identify the source of perturbation and that the demersal biota selected by trawling may be susceptible to certain forms of perturbation but not others.

This could be overcome by using a combination of different sampling techniques, and 'pooling' the results, or developing separate indices of community structure for each method. The zooplankton and macrobenthos are two communities which could be used to very good effect as biological monitors, but the practicality of incorporating them into the system is questionable. In each case far greater expenditure of manpower in terms of fieldwork and analysis is implicated. Hedgpeth (1953) and Odum & Copeland (1969) regard various lamellibranchs such as oysters and clams within coastal systems as reliable indicators of certain environmental conditions, and in retrospect it is considered unfortunate that the molluscs taken by trawling during the course of this study were not incorporated into the assessment, because many of the species encountered seemed clearly estuary- or lagoon-associated and to appear or disappear at different times (see Appendix).

Although Siegfried (1981b) believes it might be possible to use data on avian species richness and abundance to provide baselines for detecting change, from the limited attention given to this subject during the present study (see Appendix), it would not appear to be

feasible because the avifauna are opportunists and too mobile. Certain birds are excellent indicators of ecosystem types (for example in estuaries (sensu stricto) waders appeared to be immigrant species analogous to the immigrant marine ichthyofauna because of their feeding requirements, whereas in lagoons resident fish-eating birds became the counterpart of the resident ichthyofauna, and waders were absent), but avian diversity can increase in polluted systems (such as the Mvoti, Sezela and Tongati) and if stress factors such as human disturbance become intolerable (as in the Mdloti) they simply fly away to a more remote area. An impression gained during the present study period was that avian species richness was largely determined by the merits of the system as a refuge area (i.e. the protection the system offered birdlife from disturbance by human beings), whereas this is not an important determinant for the aquatic fauna. Perhaps the Sezela serves as a good example, where a comparatively rich assemblage of birds peacefully exist in the midst of an anaerobic lagoon and within earshot of a noisy sugar mill, because they are protected by an impenetrable fringe of reeds around the water body. In contrast, the system is completely lifeless below the surface of the water. Siegfried (1981b) concludes on a somewhat different note and tentatively attributes the "depauperate avifauna" of Natal's estuaries to their "impoverished invertebrate fauna, small size, paucity of intertidal banks, and artificially disturbed state."

In the final analysis therefore, of the search for "a basis upon which the future condition of estuarine systems in Natal can be measured" it would seem that the trawl susceptible fauna which embraces 125 species of fishes, crabs and prawns (Sub-App. Bi-Biv in the Appendix) has in fact provided a most encouraging start. This, I feel, is because by trawling one is in contact with the demersal fauna and therefore has one's 'finger on the pulse' of the whole system. Lastly, it is possible that amongst the assemblage of species mentioned, certain animals are more sensitive to change than others. If this is the case, an effort should then be made to establish which they are, so that they can be used as 'target species' within the monitoring system.

CHAPTER SIX

APPLICATIONS AND CONCLUSIONS

In 1978 the proceedings of the Fourth Biannual International Estuarine Research Conference was published (M.L. Wiley, ed.) and amongst the numerous subjects covered and opinions expressed, two statements in particular merit repetition before any discussion on a subject as wide ranging as the comparative ecology of Natal's smaller estuaries can meaningfully develop.

The first of these statements was by Hedgpeth (1978) who suggested that "... without really understanding the entire ecosystem we find ourselves amongst those blind men who touched various parts of the elephant without comprehending the nature of the whole animal". In light of the results of this study, and others (Reddering & Esterhuysen, 1982) there is reason to believe that if every one of the 62 systems studied (Fig.1) are regarded as estuaries, we would have the elephant firmly by the tail, and have little comprehension of the nature of these ecosystems .

Rather surprisingly the practical importance of definitions has been stressed by Day (1981) because terms such as estuaries, lagoons and river mouths are used in legislation and in the formulation of provincial regulations relating to the use (and abuse) of such water bodies. Without wishing to overemphasize the point, it has been suggested in Chapter 4 that each of the above mentioned ecosystems have entirely different bio-physical characteristics, different sensitivities to perturbation, and different ecological functions. Reddering and Esterhuysen (1982) independently arrived at the same conclusion and expressed the view that open (tidal) estuaries are significantly different from closed (non-tidal) systems. The differences mentioned include water exchange patterns, nutrient and pollution exchange patterns, the migration of various animal species, hydraulic properties and sediment dispersal. It seems essential therefore to differentiate between them (Table 18), so that there is no ambiguity about what sort of resource they represent.

Unfortunately each of these terms means a number of different things to different people. For example, Remane and Schlieper (1971) would regard those systems defined as estuaries in Natal as river

mouths, and eight different connotations of the word lagoon are given by Reddering (1980). However, in the context of the present study, and a recent review of the subject by Barnes (1980), no argument can be found with the simple definition of a lagoon given by the Oxford English Dictionary (Chap.4) because the key determinant, namely separation from the sea, is embodied within it. Likewise, no fault can be found with the admirable definition of an estuary provided by Cameron and Pritchard (1963) (Chap.4) because the key determinant, in this case free connection with the sea, is stipulated. This particular environmental variable has been shown to be the most important influence accounting for the different physical, chemical and biological characteristics of estuaries and lagoons in Natal (Fig.10), and would in fact, lead to question whether "control by the bottom materials is the dominant influence" in an estuary, as suggested by Hedgpeth (1967). In retrospect, it would appear that control by the mouth condition is the dominant influence.

The primary difference between the biological utilization of estuaries and lagoons lies in the reproductive strategies of the species involved. The community structure of estuaries is far more complex than the community structure in lagoons (refer to the overlays of Figures 12 and 13 in conjunction with Figure 14) which means that species richness is lower in closed systems than it is in open systems. This has been confirmed by Scott et al. (1952); Grindley (1980); Hodgkin and Lenanton (1980); Branch and Branch (1981) and several other workers, and results from the different manner in which the two ecosystems are 'connected' to the sea. The fact that a great many lagoons in Natal are oligohaline also means they lie within a salinity range recognized as being species poor (Remane & Schlieper, 1971). Because of these environmental differences, estuaries are dominated by species which require access to and from the sea at some stage of their life cycle, whereas in lagoons the population is dominated by species sufficiently well adapted to complete their life cycle in the system. This does not mean to say that estuary-associated species cannot be found in lagoons (and vice versa) nor that certain estuary-associated species do not complete their life cycle in estuaries. It is simply an endeavour to differentiate, at a community level, between the two.

Arising from these distinctions, it has also become clear that estuaries are supportive of immigrant species chiefly of marine origin, whilst lagoons are supportive of resident species often of freshwater origin. In other words, both fulfill a nursery function, but the origin of the species differ. The proliferation of Oreochromis mossambicus in lagoons is the reason for this statement because 95% of the 11 784 O. mossambicus caught during the survey (Sub-app.C, in the Appendix) came from lagoons. O. mossambicus is a fish that can cope with an extraordinary range of environmental conditions, with specific reference to salinity (Wallace, 1975a; Whitfield & Blaber, 1979), but it seems clear that this species has taken full advantage of lagoons because of their stability and permanence. In Lake Poelela (Whitfield & Blaber, 1976; Blaber, 1978) where connection with the sea is equally tenuous, Tilapia rendalli has done the same thing. This impression is reinforced when riverine areas upstream of coastal lagoons is examined, because for much of the study period these were either dry or scarcely flowing and choked with vegetation and sediment. Macrobrachium equidens is a freshwater species of prawn that makes good use of both estuaries and lagoons as a nursery area, although in this case brackish water is a prerequisite for larval development (Bickerton, pers.comm.; Read, 1982).

In estuaries, on the other hand, the ichthyofauna is dominated by a wide variety of marine teleosts instead of cichlidae. These include such wellknown species as perch (Acanthopagrus berda), stumpnose (Rhabdosargus spp.), grunter (Pomadasys spp.) and kob (Argyrosomus hololepidotus) as well as fishes of the ubiquitous mullet family (mugilidae). The counterpart of the carid prawns in lagoons is penaeid prawns in estuaries (including Penaeus indicus, P. monodon and P. japonicus), whilst the counterpart of the crab Rhyncoplax bovis in lagoons is Scylla serrata in estuaries. In every case the reproductive strategy of the species involved is geared either to life in estuaries (where communication with the sea is vital) or life in lagoons (where communication with the sea is not vital).

The relative size of the animals caught in estuaries and lagoons also warrants mention because the impression gained from the large size of certain estuary-associated animals found in lagoons was that these animals are semi-captive there because of mouth closure. For example, the occasional tiger prawn (P. monodon) with carapace lengths

of 63 mm can be taken from the Msimbazi Lagoon, whereas in estuaries such as the Mgeni juvenile prawns (with carapace lengths of 10 mm or less) are abundant. Another example is the massive Scylla serrata that can be taken from lagoons, with carapace widths of 152 mm. Although these animals can walk over the sandbar if they wish to return to the sea (Hill, 1975), the smallest S. serrata taken from the Msimbazi had a carapace width of 56 mm; whereas in open estuaries such as the Mgeni or Mkomazi, numerous S. serrata with carapace widths as small as 6 mm are regularly encountered. In both cases the nursery function of estuaries for these species is plausible, but not in the case of lagoons. The same sort of thing is apparent from the work of de Decker and Bennett (1983) who showed that mullet (Liza richardsoni) trapped inside the Bot River "estuary" which had been closed for four years, could not spawn and consequently were in much better physiological condition than mullet in the sea. The question which arises is what value is a system that has been closed for four years to the recruitment of mullet stocks if the population within it cannot spawn? The same situation occurs in Natal (see Mahlongwana, in the Appendix) but in this case the value of the system is seen to be not in its potential to supplement marine stocks, but in its potential to support stocks that complete their life cycle within that system, irrespective of the mouth condition.

Despite this, mullet are a group of fishes that nevertheless are abundant in many lagoons (Whitfield, 1980a; Blaber et al., 1982) but remained undersampled during the course of this study because of the trawl gear used. The reason these fishes gain access into closed systems when others such as grunter and stumpnose do not to the same degree, is probably because of their sheer abundance in the surf zone (Wallace, 1975c; Lasiak, 1981). This means they could be easily washed into lagoons at high tide when waves overtop the bar, as has been shown to occur by netting in the overwash area by Whitfield and Martin (unpublished data; Cyrus, pers.comm.). Several other species such as soles (Solea bleekeri) and the occasional blacktail (Diplodus sargus) seem to gain access in the same way.

The second statement worthy of consideration at the International Research Conference mentioned earlier is that by Schubel and Hirschberg (1978), who said "Some well-intentioned but over-zealous environmentalists have laid great stress on the importance of

estuaries for the survival of many important species of fishes and shellfishes. It would appear that such evaluations cannot be justified; which is not to say that estuaries are unimportant." It appears that Nixon (1980) came to the same conclusion when reviewing the role of saltmarshes in estuarine productivity. Nixon pointed out that in our "...enthusiasm to protect the marshes" there is a tendency to believe anything that is read about them, as many researchers "... failed to make and maintain a firm distinction between what they thought was happening ... and what they had good data to show was happening". Similarly, albeit in hindsight, with the experience gained over recent years into the comparative ecology of Natal's smaller 'estuaries' has grown the conviction that if certain concepts relating to the nursery function of estuaries are to remain credible, there is a need to exercise far more care when the word 'estuary' is used by the ecological community of South Africa, and particularly in Natal.

Hopefully, there should be no objection to taking a fresh look at this subject, if for no other reason than the dynamic nature of estuaries demands this. Stress is an inherent characteristic of estuaries, as emphasized by Knox (1980) who expressed the view that "... this meeting place of land and sea is probably the most dynamic area on earth; in which the catchword is change."

In my view, the estuaries of Natal have changed and are still changing, and so our thinking must be prepared to change. The Mkomazi is not the same place that it was in 1922 when the estuary was tidal for 13 km (King, 1972); the Mgeni is not the same estuary that it was in 1930 (see plates 11 & 13, in the Appendix); there is very little left of the Mtwalume if Thorpe's descriptions are taken into account (Begg, 1978); nothing of the original Mvoti and Mzumbe estuaries remain and from Day's description of the Msimbazi in 1950 (Begg, 1978), even that has changed. The Sezela has been totally changed by pollution, as well as the Tongati, Sipingo and Mbokodweni.

Just as river mouths no longer function as estuaries (Chap.4), lagoons which are closed off from the sea by sandbars rapidly lose this function. Herein lies another controversy, however, because many workers have failed to draw any ecological distinction between estuaries and lagoons (Day, 1980, 1981; Whitfield, 1981; Blaber et al., 1982) all of whom, like Wallace (1975a), argue that despite their

small size the importance of blind estuaries should not be underestimated because they provide "a continuous sequence of estuarine environments over a long stretch of coastline." Too many have failed to examine the concept critically seemingly "... because the credibility of the printed scientific literature was so strong ...(that)...we passed it on eagerly as one of the accomplishments of marine ecological research. And we passed it on very effectively, to students, to managers, to legislatures, to funding agencies, and to each other."(Nixon, 1980). Only Pistorius (pers. comm.) was amongst the few that voiced the opinion in 1979 that there seemed to be a "hollow ring" to the emphasis laid on estuarine dependence, and this gave rise to the present study.

One of the greatest dangers seems to have been to generalize. Of the 62 systems studied (Fig. 1), 73% were 'blind' and scientific knowledge of 45 of them was practically non-existent (Begg, 1978). Despite this, the ecological function of these very systems (with little variation) has often been described as follows:

- a) "Lagoons are subject to a seasonal cycle of opening and closing. In summer the levels of lagoons rise as a result of rain ... and eventually break through into the sea," whereas in winter " ... lagoon levels would drop because of a reduction in rainfall ... and become closed from the sea" due to sandbar formation (Heydorn, 1977).

A close examination of the data on daily mouth condition from 24 systems over periods of time ranging from 1-6 years, as well as data on water level fluctuations in the Appendix, reveals no such pattern to be evident. Instead, the opening of lagoon mouths seems to be an extremely haphazard affair that depends on numerous factors including rainfall, the porosity and crest level of the sandbar, geomorphological influences and marine influences such as overtopping of the bar. It is further complicated by man's interference through the breaching of lagoons for numerous different reasons (Begg, 1978).

- b) "Many marine creatures in Natal are adapted to utilize the estuarine situation described above (a) and are in fact, dependent upon it. These creatures include penaeid prawns which are trawled commercially in the sea and many of the reef and game fish which are exploited by line and skiboat fishermen, as well as shore anglers." (Heydorn, 1977).

Estuarine dependence is a subject that warrants a fuller discussion elsewhere in this chapter, but the results of this study would certainly not suggest that penaeid prawns, reef fish and game fish are dependent upon lagoons (superimpose Figs. 12 & 13 over Fig. 14). Instead, these species were found to be noticeably lacking in closed systems but conspicuous in open systems.

- c) "Their reproductive cycles are adapted in such a way that the juveniles are produced shortly before the mouths of lagoons open, i.e. in early summer. The juveniles then migrate into the estuaries and lagoons where they find shelter and food amongst the roots of the marginal vegetation and plant cover of the bottom." (Heydorn, 1977).

If the data on the daily mouth condition of lagoons in Natal is accepted as the first real evidence available on when lagoon mouths are open or closed in Natal, it follows that the only strategy marine organisms can use to gain access into these systems is opportunism. Lasiak (1981) is of the same opinion, and Whitfield (1980b) has demonstrated the manner in which marine species move into the Mhlanga Lagoon on those occasions that it opens. It stands to reason that far greater use is made of estuaries (sensu stricto) because they are normally open throughout the year.

Whether or not migration occurs is also debatable because despite the evidence offered by Gunter (1967) and Wallace (1975a) it remains doubtful that the marine-spawned fry and larvae that gain access into estuaries (or open lagoons) do so by actively swimming. In the first instance, the environmental cues which incite them to migrate into estuaries have never been elucidated (Day, 1981) and, in the second instance, organisms this size probably haven't the strength to swim against the currents involved. Small fish have, however, been observed

entering estuaries by moving in shallow marginal areas where water velocities are reduced (Wallace, pers.comm.). On the other hand, Melville-Smith et al. (1981) have shown that tidal currents are the mechanism by which Gilchristella larvae are swept into estuaries, and the studies of de Freitas (1980) have suggested prawn larvae are brought passively into estuaries in the same way. Pollock et al. (1983) have also shown that the postlarvae of Acanthopagrus australis (yellowfin bream) enter Moreton Bay (in Australia) on the flood tide, and mainly at night because "... fullmoon corresponds with spring tides and hence the greatest water movement into the estuary." In all likelihood, its counterpart in Natal (A. berda) does the same thing.

One could also question the validity of suggesting that the lagoons of Natal are covered in plant life; or that the roots of marginal vegetation are used for shelter; but clearly there is a need to reappraise the things that are said about lagoons when in fact it is estuaries that are being referred to.

d) "They grow to sexual maturity in the lagoons and then return to the sea to reproduce." (Heydorn, 1977).

This is what occurs in an estuary but to a far lesser extent in lagoons because the results of this study suggest that the principle occupants of lagoons are species capable of reproducing within that environment because of its separation from the sea (Fig.23).

The difference drawn between lagoons and estuaries in no way infers that a lagoon is in any way inferior to an estuary. The distinction is rather aimed towards stressing that the two have completely different functions and values, and therefore must be regarded as different resources. This has an important bearing on the hackneyed phrase 'estuarine dependence' because many species are considered to be dependent on estuaries for survival, and because several of these are of commercial and recreational importance to man.

Eighty one species of estuarine fishes in South African waters are presently regarded to be wholly or partially dependent on estuaries (Wallace et al., 1983), but the subjectivity of assessing the importance of estuaries for the survival and maintenance of these stocks remains. This stems from the difficulty of proving that the

juveniles of these species do not occur in the sea. As is pointed out by Walford (1966), Wallace (1975c) and Nakamura et al. (1980) the presence of large numbers of juvenile fishes in estuaries is not conclusive evidence that estuaries are essential as nursery grounds for these species. The evidence remains circumstantial and speculative, and especially in the light of reports of estuarine fish being trawled on the Tugela Bank (Day, 1981); the numbers of juvenile mullet and pipefish (Syngnathus spp.) collected 5 km offshore in the Agulhas Current by Ballard, (pers.comm.), and after seine netting in the surf zone at King's Beach (Port Elizabeth) Lasiak (1981) concluded that "... estuaries and nearshore waters both function as nursery areas, although the major components of their ichthyofauna differ markedly." Another intriguing aspect raised by Day (1981) is that since the juvenile fish which enter estuaries early are smaller in size than "late entries", it would appear that they have managed until then to successfully live and grow in coastal shallows. Mugil cephalus and Pomadasys commersonii have been reported in abundance in the surf zone by Wallace (1975a) and to extend from northern Zululand to as far south as Durban from August/September onwards. There was no evidence from where such shoals had come, but it is not impossible that regions as far afield as the east coast of Madagascar and the coastline of Mozambique contributed to these stocks (van der Elst, pers.comm.), what with the aid of the Agulhas Current and the inshore counter currents that have been shown to exist by Pearce and Schumann (1977).

Prescott-Allen & Prescott-Allen (1982) have also correctly stressed that far too often ecological studies are aimed at species (to minimize the chances of extinction) and ecosystem conservation, with the result that the need for genetic variation is overlooked. Many people are, therefore, unaware of the inestimable value to be derived for the benefit of mankind from the conservation of genotypes, which put simply, means the conservation of genetic resources maintains "the biosphere's capacity to be useful".

Another tendency is for people to attribute a monetary value to estuarine fisheries to impress upon others their potential economic significance. The state of this 'art' has been best developed in the USA (Taylor & Saloman, 1968; Meyer & Dolphin, 1977) but two of the most popular references cited by South African workers is that of McHugh

(1966) and de Sylva (1969). These authors pointed out that in 1965 the commercial fishery for estuarine dependent species in the USA was valued at \$75 million, and the sport fishery for these species was valued at over \$331 million. Today these fisheries must be worth considerably more, but before drawing any a parallels, it is necessary to point out that large areas of open coastal waters are regarded as estuarine zones in the USA (Schubel & Hirschberg, 1978). This is also true elsewhere in the world such as southeast Asia and in the Bay of Bengal (Blaber, 1981). It is also just as well to recall that a single estuary such as Chesapeake Bay, which alone is 6 475 km² in extent (Fischer, 1980) is 10 times greater than all the estuaries in South Africa put together. This type of resource is lacking in South Africa, as are exploitable species such as oysters, clams, shrimp, blue crab, menhaden, salmon, sturgeon, eels, flounders, alewives and striped bass (Douglas & Stroud, 1971) that are associated with estuarine areas in the USA. The total extent of estuaries in Florida alone is 12 154 km² (McNulty et al., 1972), which again serves to illustrate that in a local context, the South African coastline simply hasn't the same potential. This potential is even less in Natal because of the narrow continental shelf and relatively straight coastline. Following the advice of Hedgpeth (1975) and Rees & Davis (1978), it would seem foolhardy and dangerous to determine rand values for estuarine dependent resources in Natal because the figures derived would, by comparison, seem ridiculously small, and, what is more important, in no way reflect the enormous local significance attributed to viable estuarine fisheries. Based on the analysis of anglers' catch returns for the past 22 years (van der Elst, 1979) the CPUE for species closely associated with estuaries is declining because of estuary degradation, and this is what is crucial to South Africans, not the rand value of the estuarine dependent sport fishery. The latter is only a small part of their true value to society as a whole.

In summary therefore, although the economics of estuarine dependence in Natal are unimpressive, within the set of circumstances that surround the ecology of Natal's smaller estuaries, the importance of these systems does not lie necessarily in their value as the recruiting grounds of certain marine stocks, nor in the economic significance of these species. Instead the value of these systems

lies in their importance to man faced as he is in South Africa by exponential population growth. For example, it is a sobering thought to realize that in some other parts of Africa, such as Benin, by using brushwood in lagoons to increase the surface area for the growth of periphyton, fish yields (mainly tilapia) as high as $8\ 000\ \text{kg}\ \text{ha}^{-1}\ \text{yr}^{-1}$ have been achieved (Lowe-McConnell, 1977). The time is approaching when the potential of similar resources on our own doorstep must be examined, and an awareness created that if they are to remain viable, serious attention needs to be given to their conservation. Estuaries and lagoons are therefore regions of the coast where large numbers of relatively few species congregate and there play a part in the maintenance of a natural resource which is unquestionably of value to mankind. This may be for food or recreation, or merely to maintain a quality of life around him which he regards as important, but is in sympathy with the philosophy expressed by the IUCN (1980); Schubel & Hirschberg (1980) and Allanson (1983) that "man is the most estuarine-dependent organism in the biosphere."

This point receives far too little emphasis in scientific literature, and in the reports that are presented to those bodies responsible for the management of estuaries. This is regrettable, because it is something that such bodies are liable to understand and identify with. As pointed out by Knox (1980) "Estuarine values, problems and their solutions must be presented to the public in terms that are meaningful. If this is done, then there will be a public willingness to support the policies and costs involved in sound technical management of the estuarine zone." The lack of emphasis on man's dependence on estuaries may also account for why so little action is taken with respect to the management of estuaries in Natal and why the demise of estuaries and lagoons has fallen to its present level.

Virtually every human being is reputed to appreciate the pleasures of living on the coast or visiting the coast, where amongst many benefits, the enjoyment of fishing, boating, swimming, bird watching or even walking alongside estuaries and lagoons are important attributes (Truter & Gilmore, 1970). However, all of these things are only possible if these resources are living (sensu Poore, 1978) or ecologically functional. A sediment filled estuary (like the Mzombe) is no use to anyone and nor is a lagoon that smells revolting (like

the Sipingo), or is covered in water hyacinth because of sewage enrichment (like the Tongati), and a lifeless lagoon such as the Sezela is equally distasteful. Government, provincial and local authorities are charged with the responsibility of maintaining these resources in a living condition for man's own benefit. This is not simply for his relaxation, or the benefit to be derived from a harmonious coexistence with other forms of life, but also because, in time, resources of this nature may be important for his own survival as well. Through the mismanagement of estuaries and lagoons man is simply "cutting of his own nose to spite his face" and this he cannot afford to do if the interest of the present and future generations of this country are to be taken into consideration.

Any habitat can be characterized by its carrying capacity for certain forms of life, whether this be a lagoon filled with bream and mullet, or an estuary rich in prawns and angling species; but as its quality diminishes so does its carrying capacity. Perhaps the lesson to be learnt is that it is in man's interests to maintain a healthy coastal environment because just as this will create those qualities of life which he considers as important to have around him, the potential of both the estuarine and nearshore fisheries will be simultaneously enhanced (Newell, 1981; Pollard, 1981).

Something that these ideas, as well as Schubel and Hirschberg's provocative statement (p. 150) are designed to do is to awaken the realization that estuaries are ephemeral features of the coastline, and that once formed they are rapidly destroyed by sediments. Gorsline (1967) used the term "transient features" when pointing out that the length of life of an estuary is determined by the rate of sedimentation. This also accounts for the concern expressed by Allanson (1980, 1983) and Gladson (1981) over the rate at which man's activities overimpinge on geological processes such as erosion. In the Tugela basin for example, erosion has been accelerated 28 times according to Murgatroyd (1979). Natal is renowned for its steeply tilted condition (King, 1972) excessive population growth and the soil loss associated with these phenomena (Orme 1973; Hanks, 1976; Scotney, 1978), and this logically constitutes a greater threat to the welfare of Natal's estuaries and lagoons than any other factor. This view accounts for the attention repeatedly drawn to "river mouth transformation" in the Appendix.

This process of speeding up estuarine senescence has been most clearly described by Schubel and Hirschberg (1980) who have explained that "... sedimentation rates are highest near the head of the estuary (see Plate 41 of the Appendix for confirmation) where a delta usually forms near the new river mouth. The delta grows progressively seaward within the estuary to extend the realm of the river and force the intruding sea out of the semi-enclosed tidal basin ..." until eventually "... the river reaches the sea through a broad, depositional plain, and the transformation is complete." From a biological point of view, by this time what were estuarine biota are replaced by riverine biota.

In precisely this way the Mvoti and Mzambe river mouths have been transformed although Alexander (1979) appears to be in disagreement having said that "... it is often erroneously assumed that estuaries have become shallower as a result of sedimentation, which in turn is attributed to accelerated sediment production in their catchments (e.g. King, 1972 and Begg, 1978) ...". In his opinion all the incoming sediment is transported through the system into the sea.

Whichever school of thought is correct remains to be seen, but in Natal and throughout the world (Schubel & Hirschberg, 1980) there are estuaries in various stages of transformation. Hence the opinion has been expressed that the Mtwalume and Mpambanyoni are on the verge of final transformation and that the Mkomazi is rapidly developing in that direction. The same process occurs in lagoons, which accounts for the present day condition of the Mzimayi, Mkumbane and Siyaya (north of the study area) and several others.

The proposed classification which distinguishes between river mouths, lagoons and estuaries on ecological criteria will hopefully be of use to planners because such people are often faced with the difficulty of deciding what sort of development can be permitted in coastal areas (Odum, 1976), and in determining to what region of an estuary, or the coast certain forms of development should be confined. A classification is useful because the range of development options open to planners can be accordingly reduced or increased. For example, in considering the construction of a bridge, the need to build an open-span structure is, from an environmental point of view, more critical in an estuary than it is in a lagoon. This is because circulation in an estuary (as defined in Table 18) is tidally-induced,

whereas in a lagoon it is wind-induced. In the siting of a dam (Roberts,1983) the downstream implications of mouth closure are far more serious in an estuary, which is normally open, than in a lagoon which is normally closed. On the other hand, dam construction upstream of a river mouth could be beneficial because of sediment interception and consideration could even be given to the prospect of rehabilitation of the original estuary.

In the siting of a sewage works the quality of the final effluent is far more important if this is to be discharged into a lagoon instead of an estuary, because the lagoon is a closed system whereas in an estuary there is more likelihood of preventing eutrophication from occurring because of tidal exchange. Another example with practical implications in Natal, is in the siting of buildings and/or services such as roads, stormwater drains and water mains. These facilities are more often flooded when in the vicinity of lagoons than when adjacent to estuaries. This is because the level to which water can rise behind the sandbar in a closed system is often underestimated, whereas in estuaries the water level regime is more predictable because of the tides, and because the mouth is normally open.

In the formulation of a contingency plan against oil pollution, planners employed by the Department of Transport have found a classification as useful, for the production of sensitivity maps of the coastline (Lord, pers.comm.). This is because in comparison with estuaries, lagoons are not as vulnerable to oil pollution stemming from a spill at sea. The provision of booms to prevent the entry of oil into estuaries could be pre-planned where the mouth was known to be open (Fig.20) and the system concerned regarded as a functional estuary (Fig.10). The outflowing currents in a rivermouth on the other hand is a steady state which would make boom construction unnecessary.

Something which became most apparent during the study period was the significance of small creeks and backwaters in estuaries, because invariably the amount of life they seemed to support was considerably greater than large tracts in the main body of the estuary. One of the best examples of a well populated backwater is Beachwood Creek in the Mgeni (see Appendix).

Although estuaries are recognized as sheltered areas (Day,1981;

Blaber,1981) where the fauna is comprised of forms intolerant of the turmoil and stress of life in the open sea, backwaters seem to be sheltered areas within an already sheltered environment, and so compound the refuge value from which estuarine biota derive so much benefit. Although this is by no means a new discovery (de Freitas,1980), the reason for stressing the point is because the significance of backwaters can easily be overlooked when planning development in the close proximity of estuaries. It would be wrong to believe that if the main body of the estuary was left untouched, its nursery function will remain unaffected. In fact, it would seem the opposite applies, and so alteration to the configuration of the shoreline and marginal areas such as backwaters would be far more damaging to life in an estuary, than an activity such as sand extraction (for example) from the main body of the system.

By the same token certain developments can enhance this property of an estuary. The development of the skiboat base in the Mkomazi illustrates this point, because in construction of the slipway required, an artificial backwater to the estuary had to be constructed (see Appendix). Although insignificant in extent, this has increased the amount of shelter available in the estuary, which in this particular case was noticeably lacking. In certain situations, community structure in these backwater areas is also a lot more stable than in the main body of the estuary (see Appendix).

A classification such as that proposed in Chapter 4, may also be of assistance in making decisions regarding the potential utilities and disutilities of each ecosystem type. For example, the premature breaching of a lagoon is an activity which is considered to be disruptive and environmentally harmful (Howard-Williams & Allanson, 1979), but not in the case of an estuary. This is because the stability of a lagoon is one of its most important characteristics if it is to function at its optimal level of productivity (Whitfield, 1980a; Connell *et al.*,1977) whereas in an estuary free connection with the sea is what maintains its productivity. The opening of lagoons should therefore not be permitted, whereas the opening of an estuary that may temporarily have become closed (as happens in the Mzimkulu for example) can be overlooked. Legislation to control the breaching of lagoons in Natal is currently being formulated by the EAC for this reason, and so a classification of which systems constitute

lagoons and which are estuaries will prove useful to the local authority (NPB) eventually empowered to implement that legislation.

Government and provincial bodies are constantly required to make certain decisions regarding the use of estuarine areas, and it is foreseen that one of the most important criteria will be "what sort of system is to be affected?" Classification has shown that there are far fewer functional estuaries in Natal than is generally believed, and so an application to extract sand from the floor of an estuary is likely to be viewed with greater disfavour than an application to extract sand from a lagoon. This is because the community structure of the two ecosystems differ, and the potential for environmental damage arising from an activity of this type is likely to be greater in an estuary than in a lagoon.

The same sort of rationale can be applied whether the decision being taken relates to an application to build a marina or to use of the system for aquaculture, let alone in deciding the merits of the proposal to cut off communication with the sea in certain systems to allow them to freshen, and hence to be used as a water supply (Truter & Gilmore, 1970).

A classification of Natal's smaller estuaries has also helped convince people of the need to dredge part of the Mgeni; to consider rehabilitation of the Sezela Lagoon, as well as to question the wisdom of building a weir across the Mtamvuna, because in each case the classification has served as a means of rating the system in question by examining its present day community structure.

The relative merits of multivariate analysis of community data as a means of predicting the resilience and responses of estuaries to given forms of development have already been aired in Chapter 5. The effect of freeway construction on community structure in the uMgababa was evaluated by spatial characterization (Fig.33) for example, but the resilience of the system will only be judged once sampling is resumed at some future date. This will enable an assessment to be made of whether the upper reaches of the uMgababa have recovered since bridge construction has been completed, or remained permanently altered. The response of the Mkomazi to floods was assessed in a similar way, as well as the response of the Manzimtoti to ammonia pollution; and of the Mgeni to the disposal of spoil upstream of the estuary by dredgers. These are but a few of the ways in which the

analysis of community data is expected to be of value to user-agencies.

The planning of research is necessary at every level whether this be the funding organization or the institute and persons responsible for that research. In each case, a classification serves a useful function in the clarification of research needs.

If it is accepted that there are numerous lagoons south of the Tugela river to which estuarine functions have been attributed in the past, it would appear that the natural history of lagoons, as perceived by Barnes (1980), is indeed a neglected field of study. If one accepts that these systems do not contribute significantly to marine stocks, unlike the species recruited from estuaries, the fisheries potential of lagoons (as closed systems containing viable populations of various filter-feeding species) has not received adequate attention. However, such a study would be meaningless without a thorough understanding of productivity and the dynamics of the processes involved. One would need to examine both heterotrophic and autotrophic production, as well as production at primary, secondary and tertiary levels. An assessment of detritus production as the basic ingredient upon which the ecosystem depends; the sources from which this detritus is derived; variation in production at different times of the year and under different regimes (such as floods), the effects of water level fluctuation on production (which will incorporate breaching by natural and artificial means) and the effects of temperature and water transparency at different trophic levels.

It should be noted that there is a wide variety of lagoons varying in salinity, substratum, depth, water quality and periodicity of contact with the sea. There are also lagoons with different temperature regimes (for example those in which the bottom temperatures are significantly higher in winter) and there are lagoons dominated by different plant communities. These range from those surrounded by reeds to others characterized by submerged macrophytes; to others in which filamentous algae bloom at various times of the year, or receive considerable inputs of seaweed from the ocean through overtopping of the bar.

Classification has also shown that a concerted effort should be made to determine the tidal prism in each estuary, and during open phases in each lagoon. This variable is of undoubted significance in

accounting for the differing ecological character of each system. The value of data on the daily mouth condition of estuaries and lagoons has proved to be invaluable, but in many cases is still lacking altogether. Particular attention should be paid to ascertaining the opening mechanism involved (man-induced, fluvial or marine) if any interpretation of the cause and effect is desired.

Another requirement is a classification of Natal's estuaries and lagoons using socio-economic criteria instead of ecological criteria. The two classifications would be complementary to one another and serve to greatly improve the value judgements presently being made of these resources.

Finally, the value of classification in selecting areas for conservation can be briefly considered.

The word conservation has been defined in Chapter 1 and hence the 'rational use' of coastal resources is seen to be the ultimate purpose of this study. For resources such as lagoons and estuaries to be used rationally it has been necessary to classify them so that their users know what type of resource they are and what their sensitivities are likely to be. This provides some assurance that they will be used in the most sensible manner. Furthermore, with the realisation that very few of Natal's estuaries south of the Tugela are truly functional (Chap. 4), has followed a greater sense of urgency than ever before, that active steps are indeed necessary to conserve these assets by proper management (Little, pers. comm.).

If it is accepted that after a century of human development and progress, there is not one estuary or lagoon in Natal which is in a pristine condition, then the wisdom expressed by Poore (1978) warrants attention. Poore states "... the proper management of modified ecosystems is of the greatest possible importance in the conservation of living natural resources; it is indeed the essence of good conservation."

Relatively undisturbed systems such as the Mtamvuna, Mhlanga, Mdlotane and uMgababa are obvious candidates for conservation (Grindley & Cooper, 1979). This is because they have a good chance of remaining undisturbed in the future, and thus should be accorded maximum protection; but one cannot help but wonder in the light of the "island dilemma" expressed by Diamond (1975), if the conservation of such small entities will make any real difference beyond providing

a natural area for the few privileged human beings that are periodically allowed to visit them. Whilst there is certainly merit in having such areas conserved to act as reference sites for comparison with estuaries which have been disturbed (Siegfried,1978), in reality, it is highly unlikely such small reserves will fully protect the spectrum of wild genetic resources that so urgently require conservation.

In conclusion, the only way in which the interests of nature conservation can really be served is through the implementation of a comprehensive nation-wide policy to conserve estuaries and lagoons throughout the country no matter how large or small. Perhaps the most important need of all is "for man to recover a sense of reverence for the land ..." (Brant, 1979), because time is running out, and it is necessary that people in the highest tiers of government are made to realize that through population pressures, man and natural resources such as estuaries are becoming increasingly interdependent. It is towards this end, above all else, that the present study has been directed, because I derive no comfort from the fact that in the coastal zone of Natal, the only habitats that are increasing are built up areas and degraded estuaries and lagoons.

REFERENCES

- ALEXANDER, W.J.R., 1979. Sedimentation of estuaries: Causes, effects and remedies. Fourth National Oceanographic symposium, Cape Town, 10-13 Jul 1979: 1-8. Unpublished paper.
- ALLANSON, B.R., 1980. Estuaries: history and importance. International symposium on habitats and their influence on wildlife, University of Pretoria, 3-4 Jul 1980: 123-130.
- ALLANSON, B.R., 1939. Estuarine degradation: Causes and effects. South African journal of science, 79(4): 159. Abstract.
- ANON., 1983. The SANCOR estuaries programme, 1982-1986. South African national scientific programmes report, (67): 1-42.
- ARFI, R., CHAMPALPERT, G., PATRITI, G. with the participation of the EPOPEM group, 1981. Système planctonique et pollution urbaine: un aspect des populations zooplanctoniques. Marine biology, 61(2/3): 133-141.
- BARNARD, K.H., 1950. Descriptive catalogue of South African Decapod Crustacea. Annals of the South African museum, 38: 1-864.
- BARNES, R.S.K., 1974. Estuarine biology. London, Edward Arnold: 1-76.
- BARNES, R.S.K., 1980. Coastal lagoons: The natural history of a neglected habitat. Cambridge, Cambridge University Press: 1-106.
- BECHTEL, J.J. & COPELAND, B.J., 1970. Fish species diversity indices as indicators of pollution in Galveston Bay, Texas. Contributions in marine science, 15: 103-132.
- BEDFORD, J.W., ROELOFS, E.W. & ZABIK, M.J., 1968. The freshwater mussel as a biological monitor of pesticide concentrations in a lotic environment. Limnology and oceanography, 13(1): 118-126.
- BEGG, G.W., 1978. The estuaries of Natal. Natal town and regional planning report, 41: 1-657.
- BEGG, G.W., 1979. Policy proposals for the estuaries of Natal. Natal town and regional planning report, 43: 1-39.
- BEGG, G.W., 1980. Factors affecting the quality of the estuarine environment in Natal. International symposium on habitats and their influence on wildlife, University of Pretoria, 3-4 Jul 1980: 50-69.
- BERTINE, K. ... (et al)., 1979. Estuaries. In: Proceedings of a workshop on assimilative capacity of U.S. Coastal waters for pollutants, Crystal Mountain, 29 Jul-4 Aug 1979: 59-97.
- BLABER, S.J.M., 1976. The food and feeding ecology of mullet in the St Lucia lake system. The St Lucia Scientific Advisory Council Workshop meeting, Charters Creek, 15-17 Feb 1976: 1-10.

- BLABER, S.J.M., 1978. Fishes of the Kosi system. Lammergeyer, (24): 28-41.
- BLABER, S.J.M., 1980. The functioning of estuaries in southern Africa. International symposium on habitats and their influence on wildlife, University of Pretoria, 3-4 Jul 1980: 26-34.
- BLABER, S.J.M., 1981. The zoogeographical affinities of estuarine fishes in South East Africa. South African journal of science, 77(7): 305-309.
- BLABER, S.J.M. & BLABER, T.G., 1980. Factors affecting the distribution of juvenile estuarine and inshore fish. Journal of fish biology, 17(2): 143-162.
- BLABER, S.J.M., HAY, D.G., CYRUS, D.P. & MARTIN, T.J., 1982. The ecology of two degraded estuaries on the north coast of Natal. Unpublished report. South African nature foundation: 1-19.
- BLABER, S.J.M., HILL, B.J. & FORBES, A.T., 1974. Infratidal zonation in a deep South African estuary. Marine biology, 28(4): 333-337.
- BLABER, S.J.M. & WHITFIELD, A.K., 1977. The biology of the burrowing goby Croilia mossambica Smith (Teleostei, Gobiidae). Environmental biology of fishes, 1(2): 197-204.
- BOESCH, D.F., 1973. Classification and community structure of macrobenthos in the Hampton Roads area, Virginia. Marine biology, 21(3): 226-244.
- BOND, R.M., 1935. Investigation of some hispaniolan lakes. Archiv für hydrobiologie, 28: 137-161.
- BOWDEN, K.F., 1967. Circulation and diffusion. In: LAUFF, G.H. ed. Estuaries. Washington D.C., American association for the advancement of science: 15-36.
- BRANCH, G. & BRANCH, M., 1981. The living shores of Southern Africa. Cape Town, C. Struik: 1-272.
- BRANCH, G.M. & GRINDLEY, J.R., 1979. The ecology of South African estuaries. Part XI: Mngazana, a mangrove estuary. South African journal of zoology, 14(3): 149-170.
- BRAND, P.A.J., KEMP, P.H., PRETORIUS, S.J. & SCHOONBEE, H.J., 1967. Water quality and abatement of pollution in Natal rivers, 1: Objectives of river surveys, description of methods used and discussion of water quality criteria. Natal town and regional planning report, 13(1): 1-101.
- BRAND, P.A.J., KEMP, P.H., PRETORIUS, S.J. & SCHOONBEE, H.J., 1967. Water quality and abatement of pollution in Natal rivers, 2: Survey of the Three Rivers region. Natal town and regional planning report, 13(2): 1-224.

- BRANT, C.A., 1979. How can you buy or sell the sky? In: Voices of the wilderness. Proceedings of the First World Wilderness Congress, Johannesburg, 24-28 Oct 1977. Johannesburg, Jonathan Ball: 17-23.
- BRAY, J.R. & CURTIS, J.T., 1957. An ordination of the upland forest communities of southern Wisconsin. Ecological monographs, 27: 325-349.
- BREEN, C., 1982. Introduction and definition of wetlands. Unpublished memo prepared for a discussion on a "Management strategy for wetlands in Natal" held at the offices of the Natal Town and Regional Planning Commission, 19 March 1982: 1-7.
- BROEKHUYSEN, G.J. & TAYLOR, H., 1959. The ecology of South African estuaries, 8: Kosi Bay estuary system. Annals of the South African Museum, 44: 279-296.
- BRUTON, M.N., 1980. Introduction. In: BRUTON, M.N. & COOPER, K.H. eds. Studies on the ecology of Maputaland. Grahamstown, Rhodes University and The Natal branch of the wildlife society of Southern Africa: XVII-XIX.
- BRUTON, M.N. & KOK, H.M., 1980. The freshwater fishes of Maputaland. In: BRUTON, M.N. & COOPER, K.H. eds. Studies on the ecology of Maputaland. Grahamstown, Rhodes University and The Natal branch of The wildlife society of Southern Africa: 210-244.
- BUZAS, M.A., 1970. Spatial homogeneity: statistical analyses of unispecies and multispecies populations of Foraminifera. Ecology, 51: 874-879.
- CAIRNS, J., 1974. Indicator species vs the concept of community structure as an index of pollution. Water resources bulletin, 10: 338-347.
- CAMERON, W.M. & PRITCHARD, D.W., 1963. Estuaries. In: HILL, M.N., ed. The sea: Ideas and observations on the progress in the study of the seas, v.2: New York, John Wiley and Sons: 306-324.
- CAMPBELL, G.D. & ALLANSON, B.R., 1952. The fishes of the 1947, 1948 and 1949 scientific investigations of the Kosi area, organised by the Natal society for the preservation of wild life and natural resorts. Natal society for the preservation of wild life and natural resorts, 1(4): 13-20.
- CARNEY, R.S. & CAREY, A.G., 1980. Effectiveness of metering wheels for measurement of area sampled by beam trawls. Fishery bulletin, 78(3): 791-796.
- CASPERS, H., 1967. Estuaries. Analysis of definitions and biological considerations. In: LAUFF, G.H. ed. Estuaries. Washington D.C., American association for the advancement of science: 6-8.

- CASSIE, R.M., 1967. Mathematical models for the interpretation of inshore plankton communities. In: LAUFF, G.H. ed. Estuaries. Washington D.C., American association for the advancement of science: 509-514.
- CONNELL, A.D., McCLURG, T.P. & UJFALUSI, M., 1977. Environmental pollution studies: Estuarine surveys: Umgababa Estuary. Progress report, CSIR/NIWR 35th steering committee meeting: Marine disposal of effluents, (34): 1-6.
- CRONIN, L.E., 1967. The role of man in estuarine processes. In: LAUFF, G.H. ed. Estuaries. Washington D.C., American association for the advancement of science: 667-689.
- DAHL, E., 1956. Ecological salinity boundaries in poikilohaline waters. Oikos, 7: 1-21.
- DAY, J.H., 1951. The ecology of South African estuaries, 1: A review of estuarine conditions in general. Transactions of the royal society of South Africa, 33(1): 53-91.
- DAY, J.H., 1967. The biology of Knysna Estuary, South Africa. In: LAUFF, G.H. ed. Estuaries. Washington D.C., American association for the advancement of science: 397-407.
- DAY, J.H., 1969. A guide to marine life on South African shores. Cape Town, A.A. Balkema: 1-300.
- DAY, J.H., 1974. The ecology of Morrumbene Estuary, Mozambique. Transactions of the royal society of South Africa, 34: 129-156.
- DAY, J.H., 1980. What is an estuary? South African journal of science, 76(5), 1980: 198.
- DAY, J.H., 1981. Estuarine ecology: with particular reference to Southern Africa. Cape Town, A.A. Balkema: 1-411.
- DAY, J.H., FIELD, J.G. & MONTGOMERY, M.P., 1971. The use of numerical methods to determine the distribution of the benthic fauna across the continental shelf of North Carolina. Journal of animal ecology, 40: 93-126.
- DAY, J.H., MILLARD, N.A.H. & BROEKHUYSEN, G.J., 1954. The ecology of South African estuaries, 4: The St Lucia system. Transactions of the royal society of South Africa, 34(1): 129-156.
- DE DECKER, H.P. & BENNETT, B.A., 1983. Comparison of the physiological condition of the mullet, Liza richardsoni (Smith), in a closed estuary and in the sea. South African journal of science, 79(4): 156. Abstract.
- DE FREITAS, A.J., 1972. Chave simplificada para identificacao dos penaeideos de Baia de Lourenco Marques (Mocambique). Biomar, (1): 1-6.

- DE FREITAS, A.J.O., 1980. The Penaeoidea of southeast Africa. Unpublished Ph.D. thesis, University of the Witwatersrand, Johannesburg: 1-480.
- DE SYLVA, D.P., 1969. Trends in marine sport fisheries research. Transactions of the American fisheries society, 98(1): 151-169.
- DEN HARTOG, C., 1960. Comments on the Venice-System for the classification of brackish waters. Internationale revue der gesamten hydrobiologie, 45(4): 481-485.
- DIAMOND, J.M., 1975. The island dilemma: Lessons of modern biogeographic studies for the design of natural reserves. Biological conservation, 7: 129-146.
- DOUGLAS, P.A. & STROUD, R.H., eds., 1971. A symposium on the biological significance of estuaries, Houston, Texas, 13 Feb 1970. Washington D.C., Sport fishing institute: 1-111.
- FIELD, J.G., CLARKE, K.R. & WARWICK, R.M., 1982. A practical strategy for analysing multispecies distribution patterns. Marine ecology - Progress series, 8: 37-52.
- FIELD, J.G. & MCFARLANE, G., 1968. Numerical methods in marine ecology. 1. A quantitative 'similarity' analysis of rocky shore samples in False Bay, South Africa. Zoologica africana, 3: 119-137.
- FIELD, J.G. & ROBB, F.T., 1970. Numerical methods in marine ecology. 2. Gradient analysis of rocky shore samples from False Bay. Zoologica africana, 5(2): 191-210.
- FINCH, V.C., TREWARTHA, G.T., ROBINSON, A.H. & HAMMOND, E.H., 1957. Elements of geography. New York, McGraw-Hill Book Co. Inc: 1-693.
- FISCHER, A.C., 1980. My Chesapeake - Queen of bays. National geographic, 158(4): 428-467.
- FORBES, A.T., 1979. Distribution and status of the burrowing sand-prawn in the Kosi Lake system. Lammergeyer, (27): 41-45.
- GAUCH, H.G., 1982. Multivariate analysis in community ecology. Cambridge, Cambridge University Press: 1-298.
- GLADSON, J., 1981. Estuaries. Oregon wildlife, 36(12): 3-8.
- GOODALL, D.W., 1953. Objective methods for the classification of vegetation, I: The use of positive interspecific correlation. Australian journal of botany, 1(1): 39-63.
- GOODALL, D.W., 1954. Objective methods for the classification of vegetation, III: An essay in the use of factor analysis. Australian journal of botany, 2(3): 304-324.

- GORSLINE, D.S., 1967. Contrasts in coastal bay sediments on the Gulf and Pacific coasts. In: LAUFF, G.H. ed. Estuaries. Washington D.C., American association for the advancement of science: 219-225.
- GOSSELINK, J.R. & TURNER, R.E., 1978. The role of hydrology in freshwater wetland ecosystems. In: GOOD, R.E., WHIGHAM, D.F. & SIMPSON, R.L. eds. Freshwater wetlands, ecological processes and management potential. New York, Academic Press: 63-78.
- GREEN, R.H., 1979. Sampling design and statistical methods for environmental biologists. New York, John Wiley and Sons: 1-257.
- GREEN, R.H. & VASCOTTO, G.L., 1978. A method for the analysis of environmental factors controlling patterns of species composition in aquatic communities. Water research, 12: 583-590.
- GREEN, T., 1979. The Thames reborn. Reader's digest, 114(686): 158-162.
- GRINDLEY, J.R., 1972. Ecological challenges for designers of engineering works affecting estuaries. ECOR symposium on the ocean's challenge to South African engineers, Stellenbosch, 22-24 Nov 1972: 1-10.
- GRINDLEY, J.R., 1974. Estuaries: An endangered habitat. African wildlife, 28(1): 23-26.
- GRINDLEY, J.R., 1980. Conservation of the habitats of estuarine invertebrates. International symposium on habitats and their influence on wildlife, University of Pretoria, 3-4 Jul 1980: 35-43.
- GRINDLEY, J.R. & COOPER, K.H., 1979. Proposals for the establishment of estuarine reserves: A report by the Council for the Habitat and the Wildlife Society of Southern Africa. Durban, The Wildlife Society of Southern Africa: 1-35.
- GUNTER, G., 1957. Dredges and trawls. In: HEDGPETH, J.W. ed. Treatise on marine ecology and paleoecology, v.1: Ecology. New York, Geological society of America: 1-1296.
- GUNTER, G., 1967. Some relationships of estuaries to the fisheries of the Gulf of Mexico. In: LAUFF, G.H. ed. Estuaries. Washington D.C., American association for the advancement of science: 621-638.
- HAEDRICH, R.L. & HAEDRICH, S.O., 1974. A seasonal survey of the fishes in the Mystic River, a polluted estuary in downtown Boston, Massachusetts. Estuarine and coastal marine science, 2: 59-73.
- HALL, J.B. & SWAINE, M.D., 1976. Classification and ecology of closed canopy forest in Ghana. Journal of ecology, 64: 913-951.

- HAMER, A.D. & SOULSBY, P.G., 1980. An approach to chemical and biological river monitoring systems. Water pollution control, 79: 56-69.
- HANKS, J., 1976. What is conservation? 28th Annual conservation conference of the natural resources board, Rhodesia, Victoria Falls, 2-3 Jun 1976: 1-16.
- HANSEN, D.V. & RATTRAY, M., 1966. New dimensions in estuary classification. Limnology and oceanography, 11(3): 319-326.
- HEDGPETH, J.W., 1953. An introduction to the zoogeography of the northwestern Gulf of Mexico with reference to the invertebrate fauna. Publications of the institute of marine science, University of Texas, 3: 107-224.
- HEDGPETH, J.W., 1957. Estuaries and lagoons, II: Biological aspects. In: HEDGPETH, J.W. ed. Treatise on marine ecology and paleoecology, v.1: Ecology. New York, Geological society of America: 1-1296.
- HEDGPETH, J.W., 1967. The sense of the meeting. In: LAUFF, G.H. ed. Estuaries. Washington D.C., American association for the advancement of science: 707-710.
- HEDGPETH, J.W., 1975. Seven ways to obliteration: Factors of estuarine degradation. In: United States Environmental Protection Agency, Estuarine Pollution Control and Assessment: Proceedings of a conference. Washington D.C., Office of the water planning standards: 723-727.
- HEDGPETH, J.W., 1978. As blind men see the elephant: The dilemma of a marine ecosystem research. In: WILEY, M.L. ed. Estuarine interactions. New York, Academic Press: 3-15.
- HEMENS, J., McCLURG, T.P., SIMPSON, D.E., WARWICK, R.J. & WALLACE, J.H., 1971. Detailed survey of Richards Bay. Progress report, CSIR/NIWR 22nd steering committee meeting: Marine disposal of effluents, (21): 1-13.
- HEMENS, J., METZ, H., SIMPSON, D.E. & WARWICK, R.J., 1972. Natal coast estuaries: Environmental surveys, 4: The Amatikulu Estuary. Progress report, CSIR/NIWR 25th steering committee meeting: Marine disposal of effluents, (24): 1-11.
- HEMENS, J., METZ, H., SIMPSON, D.E. & WARWICK, R.J., 1973. Natal coast estuaries: Environmental surveys, 6: The Umtamvuna Estuary. Progress report, CSIR/NIWR 26th steering committee meeting: Marine disposal of effluents, (25): 1-10.
- HEMENS, J., SIMPSON, D.E. & McCLURG, T.P., 1970. Detailed survey of Richards Bay. Progress report, CSIR/NIWR 20th steering committee meeting: Marine disposal of effluents, (20): 1-29.

- HEYDORN, A.E.F., 1972. South African estuaries, their function and the threat to their existence. Findiver, (32): 18-19.
- HEYDORN, A.E.F., 1973. South African estuaries an economic asset or a national resource being squandered? Natal wildlife, 14(4): 10-15.
- HEYDORN, A.E.F., 1977. Relevant points concerning the proposal to develop a Marina on Umhlanga Lagoon. Marina Natalia Seminar, Umhlanga Rocks, 16 Jul 1977: 1-4.
- HEYDORN, A.E.F. & TINLEY, K.L., 1980. Estuaries of the Cape. 1: Synopsis of the Cape coast - natural features, dynamics and utilization. Stellenbosch, National Research Institute for Oceanology: 1-96.
- HEYDORN, A.E.F. & WALLACE, J.H., 1973. Report to the Department of Bantu Administration and Development on the role of the fauna of Kosi Lake system and the associated coastal regions in terms of the possible proclamation of a Nature Reserve: 1-12.
- HILL, B.J., 1975. Abundance, breeding and growth of the crab Scylla serrata in two South African estuaries. Marine biology, 32: 119-126.
- HILL, M.O., 1979(a). TWINSPAN: a FORTRAN program for arranging multivariate data in an ordered two-way table by classification of the individuals and attributes. New York, Cornell University: 1-48.
- HILL, M.O., 1979(b). DECORANA: a FORTRAN program for detrended correspondence analysis and reciprocal averaging. New York, Cornell University: 1-31.
- HODGKIN, E.P. & LENANTON, R.C., 1980. Estuaries and coastal lagoons of South Western Australia. Perth, Department of Conservation and the Environment. Unpublished report: 1-19.
- HOWARD-WILLIAMS, C. & ALLANSON, B.R., 1979. The ecology of Swartvlei: Research for planning and future management. Pretoria, Water Research Commission: 1-26.
- HUNTLEY, B. & BIRKS, H.J.B., 1979. The past and present vegetation of the Morrone Birkwoods National Nature Reserve, Scotland. 1: A primary phytosociological survey. Journal of ecology, 67: 417-446.
- HUNTLEY, B.J., 1978. Ecosystem conservation in Southern Africa. In: WERGER, M.J.A. & VAN BRUGGEN, A.C. eds. Biogeography and ecology of Southern Africa, The Hague, Dr W. Junk: 1333-1384.
- INTERNATIONAL UNION FOR CONSERVATION OF NATURE AND NATURAL RESOURCES, 1980. World conservation strategy: Living resource conservation for sustainable development. Gland, IUCN: 1-47.

- JENNINGS, J.N. & BIRD, E.C.F., 1967. Regional geomorphological characteristics of some Australian estuaries. In: LAUFF, G.H. ed. Estuaries. Washington D.C., American association for the advancement of science: 121-128.
- JOHNSON, D.W., 1919. Shore processes and shoreline development. New York, John Wiley and Sons, Inc.: 1-217.
- JONES, J.R., TRACY, B.H., SEBAUGH, J.L., HAZELWOOD, D.H. & SMART, M.M., 1981. Biotic index for ability to assess water quality of Missouri Ozark streams. Transactions of the American fisheries society, 110: 627-637.
- KENNEDY, V.S. ed., 1980. Estuarine perspectives. New York, Academic Press: 1-533.
- KETCHUM, B.H., 1969. Eutrophication of estuaries. In: Eutrophication: Causes, consequences, correctives: Proceedings of a symposium. Washington D.C., National academy of sciences: 1-661.
- KING, L.C., 1972. The Natal monocline explaining the origin and scenery of Natal, South Africa. Durban, Geology Department, University of Natal: 1-113.
- KNOX, G.A., 1980. The estuarine zone: An overview. Soil and water, April 1980: 13-28.
- KOOP, K., BALLY, R. & McQUAID, C.D., 1983. The ecology of South African estuaries. Part XII: The Bot River, a closed estuary in the south-western Cape. South African journal of zoology, 18: 1-10.
- LANCE, G.N. & WILLIAMS, W.T., 1967. A general theory of classificatory programs, 1: Hierarchical systems. Computer journal, 9: 373-380.
- LANKFORD, R.R., 1976. Man's use of coastal lagoon resources. Abstracts of papers. Joint oceanographic assembly, Edinburgh, 13-24 Sep 1976: 9.
- LANKFORD, R.R., 1977. Coastal lagoons of Mexico. Their origin and classification. In: WILEY, M.L. ed. Estuarine processes, v.2. New York, Academic Press: 182-215.
- LASIAK, T.A., 1981. Nursery grounds of juvenile teleosts: Evidence from the surf zone of King's Beach, Port Elizabeth. South African journal of science, 77(9): 388-390.
- LIVINGSTON, R.J., 1979. Multiple factor interaction and stress in coastal systems: A review of experimental approaches and field implications. In: VERNBERG, W.B., CALABRESE, A., THURBERG, F.P. & VERNBERG, F.J. eds. Marine pollution: Functional responses. New York, Academic Press: 389-414.

- LOWE-McCONNELL, R.H., 1977. Ecology of fishes in tropical waters. The Institute of Biology's Studies in Biology, (76). London, Edward Arnold Ltd: 1-64.
- MAUD, R.R., 1961. A preliminary review of the structure of coastal Natal. Transactions of the geological society of South Africa, 64:247-256.
- MAUD, R.R., 1980. The present drought in Natal and KwaZulu in relation to climatic changes. Natal wildlife, 21(10): 10-12.
- McCALL, P.L., 1978. Spatial-temporal distributions of Long Island Sound infauna: The role of bottom disturbance in a nearshore marine habitat. In: WILEY, M.L. ed. Estuarine interactions. New York, Academic Press: 191-219.
- McHUGH, J.L., 1966. Management of estuarine fisheries. In: SMITH, R.F., SWARTZ, A.H. & MASSMAN, W.H. eds. A symposium on estuarine fisheries. Special publications. American fisheries society, (3): 133-154.
- McHUGH, J.L., 1968. Are estuaries necessary? Commercial fisheries review, 1968: 37-45.
- McNULTY, J.K., LINDALL, W.N. & SYKES, J.E., 1972. Cooperative Gulf of Mexico estuarine inventory and study, Florida: Phase 1, Area description. NOAA technical report NMFS CIRC, (368): 1-126.
- MELVILLE-SMITH, R., BAIRD, D. & WOOLDRIDGE, T., 1981. The utilization of tidal currents by the larvae of an estuarine fish. South African journal of zoology, 16: 10-13.
- MEYER, P.A. & DOLPHIN, D.R., 1977. A system for determining economic loss associated with estuary degradation. Coastal zone management journal, 3(4): 385-404.
- MILLARD, N.A.H. & BROEKHUYSEN, G.J., 1970. The ecology of South African estuaries, 10: St Lucia: A second report. Zoologica africana, 5(2): 277-307.
- MILLARD, N.A.H. & HARRISON, A.D., 1954. The ecology of South African estuaries, 5: Richards Bay. Transactions of the royal society of South Africa, 34(1): 157-179.
- MOES, J., 1979. 'n Wiskundige model vir die bepaling van stabiliteit van getymondings aan sediment kuste. Unpublished M.Sc. thesis, University of Stellenbosch, Stellenbosch: 1-395.
- MOORE, J.J., FITZSIMONS, P., LAMBE, E. & WHITE, J., 1970. A comparison of some phytosociological techniques. Vegetatio, 20: 1-20.

- MORANT, P.D., 1981. Wetland classification: A review of existing wetland classification systems and their applicability in Southern Africa. Unpublished M.Sc. thesis, University of Cape Town, Rondebosch: 1-180.
- MORANT, P.D. & GRINDLEY, J.R. (comps.), 1982. Estuaries of the Cape. Part 2. Synopses of available information on individual systems. Report No.14. Sand (CSW4). CSIR/NRIO. Estuarine and coastal research unit - ECRU. CSIR research report, (413): 1-70.
- MURGATROYD, A.L., 1979. Geologically normal and accelerated rates of erosion in Natal. South African journal of science, 75: 395-396.
- NAKAMURA, E.L., TAYLOR, J.R. & WORKMAN, I.K., 1980. The occurrence of life stages of some recreational marine fishes in estuaries of the Gulf of Mexico. NOAA technical memorandum NMFS-SEFC-45: 1-55.
- NATIONAL RESEARCH INSTITUTE FOR OCEANOLOGY, 1981. Hydrological/hydraulic study of Natal estuaries: Data report No.5. Mzumbi NS 26. Confidential report NRIO/CSIR: (1-13).
- NATIONAL RESEARCH INSTITUTE FOR OCEANOLOGY, 1982. Hydrological/hydraulic study of Natal estuaries: Data report No.9. Mloti NN3. Confidential report NRIO/CSIR: 1-12.
- NEWELL, B.S., 1981. Inshore region a vital but vulnerable fish habitat. Australian fisheries, 40(1): 3-6.
- NIXON, S.W., 1980. Between coastal marshes and coastal waters - a review of 20 years of speculation and research on the role of salt marshes in estuarine productivity and water chemistry. In: HAMILTON, P. & MACDONALD, K.B. eds. Estuarine and wetland processes with emphasis on modelling. New York, Plenum Press: 438-525.
- NOBLE, R.G. & HEMENS, J., 1978. Inland water ecosystems in South Africa - a review of research needs. South African national scientific programmes report, (34): 1-150.
- NOY-MEIR, I., 1973. Divisive polythetic classification of vegetation data by optimized division on ordination components. Journal of ecology, 61: 753-760.
- ODUM, H.T. & COPELAND, B.J., 1969. A functional classification of the coastal systems of the United States. In: ODUM, H.T., COPELAND, B.J. and McMAHON, E.H. Coastal ecological systems of the United States. Washington D.C., Water pollution Control Administration : 9-86.
- ODUM, W.E., 1970. Insidious alteration of the estuarine environment. Transactions of the American fisheries society, 99(4): 836-843.
- ODUM, W.E., 1976. Ecological guidelines for tropical coastal development. IUCN publications new series, (42): 1-60.

- OLIFF, W.D., TURNER, W.D., CONNELL, A.D., McCLURG, T.P., GARDNER, B.D., GERTENBACH, W.J.B. & ENGELBRECHT, E., 1977. Environmental pollution studies, C: Estuarine surveys; V: Umgababa Estuary. Progress report, CSIR/NIWR 34th steering committee meeting: Marine disposal of effluents, (33): 85-101.
- OLIFF, W.D., TURNER, W.D., CONNELL, A.D., McCLURG, T.P., GARDNER, B.D., GERTENBACH, W.J.M. & ENGELBRECHT, E., 1977. Environmental pollution studies, C: Estuarine surveys; VI: The Kosi Bay estuarine lakes. Progress report, CSIR/NIWR 34th steering committee meeting: Marine disposal of effluents, (33): 102-125.
- OLIFF, W.D., TURNER, W.D., CONNELL, A.D., McCLURG, T.P., GARDNER, B.D., GERTENBACH, W.J.N. & ENGELBRECHT, E., 1977. Environmental pollution studies: Estuarine surveys, VII: Richards Bay Harbour - November 1976. Progress report, CSIR/NIWR 34th steering committee meeting: Marine disposal of effluents, (33): 126-146.
- ORME, A.R., 1973. Barrier and lagoon systems along the Zululand coast, South Africa. In: COATES, D.R. ed. Coastal geomorphology. Binghamton, State university of New York: 181-217. Technical report, Office of naval research, (1).
- ORME, A., 1974. Estuarine sedimentation along the Natal coast, South Africa. Technical report, Office of naval research, (5): 1-53.
- PEARCE, A.F. & SCHUMANN, E.H., 1977. A review of present concepts on Natal coast circulation. Progress report, CSIR/NIWR 34th steering committee meeting: Marine disposal of effluents, (33): 1-15.
- POLLARD, D.A., 1976. Estuaries must be protected. Australian fisheries, 35: 6-10.
- POLLARD, D.A., 1981. Estuaries are valuable contributions to fisheries production. Australian fisheries, 40(1): 7-9.
- POLLOCK, B.R., WENG, H. & MORTON, R.M., 1983. The seasonal occurrence of yellowfin bream, Acanthopagrus australis (Gunther), and some factors affecting their movement into an estuary. Journal of fish biology, 22: 409-415.
- POORE, D., 1978. Ecosystem conservation: Sourcebook for a world conservation strategy. General assembly paper GA 78/10. Add. (4): 1-25. Second draft.
- PRESCOTT-ALLEN, R. & PRESCOTT-ALLEN, C., 1982. What's wildlife worth? Economic contributions of wild plants and animals to developing countries. London, Earthscan: 1-92.
- PRITCHARD, D.W., 1967. What is an estuary: Physical viewpoint. In: LAUFF, G.H. ed. Estuaries. Washington D.C., American association for the advancement of science: 3-5.

- RAINER, S.F. & FITZHARDINGE, R.C., 1981. Benthic communities in an estuary with periodic deoxygenation. Australian journal of marine and freshwater research, 32(2): 227-243.
- READ, G., 1982. An ecophysiological study of the effects of temperature and salinity on the distribution of Macrobrachium petersi in the Keiskamma River and estuary. Unpublished Ph.D. thesis, Rhodes University, Grahamstown: 1-177.
- REDDERING, J.S.V., 1980. What is an estuary? South African journal of science, 76(8): 340-341.
- REDDERING, J.S.V. & ESTERHUYSEN, K., 1982. Fluviually dominated sedimentation in the Great Fish Estuary. Port Elizabeth, Department of geology, University of Port Elizabeth. ROSIE report (4): 1-62.
- REDEKE, H.C., 1922. Zur biologie der niederländischen brackwassertypen Bijdragen tot de dierkunde, 22: 329-335.
- REES, W.E. & DAVIS, H.C., 1978. Coastal ecosystem planning and impact evaluation. Coastal zone '78, San Francisco, 14 Mar 1978: 601-620.
- REMANE, A. & SCHLIEPER, C., 1971. Biology of brackish water. New York, John Wiley and Sons: 1-372.
- ROBERTS, C.P.R., 1983. Environmental constraints on water resources development. Seventh quinquennial convention of the South African Institution of Civil Engineers, Cape Town, Oct 1983: 1-23. Draft.
- ROCHFORD, D.J., 1951. Studies in Australian estuarine hydrology, 1: Introductory and comparative features. Australian journal of marine and freshwater research, 2: 1-116.
- SCHUBEL, J.R. & HIRSCHBERG, D.J., 1978. Estuarine graveyards, climatic change, and the importance of the estuarine environment. In: WILEY, M.L. ed. Estuarine interactions. New York, Academic Press: 285-303.
- SCHUBEL, J.R. & HIRSCHBERG, D.J., 1980. The estuary revisited. Water spectrum, 12(2): 1-9.
- SCHWARTZ, F.J., 1981. Effects of freshwater runoff on fishes occupying the freshwater and estuarine coastal watersheds of North Carolina. In: CROSS, R.D. & WILLIAMS, D.L. eds. Proceedings of the national symposium on freshwater inflow to estuaries, 1: 282-294.
- SCOTNEY, D.M., 1978. The present situation in Natal. Agriculture and environmental conservation in Natal and KwaZulu, Durban, 19-20 Oct 1978. Symposium organised by The wildlife society of Southern Africa and The royal society of South Africa: 16-34.

- SCOTT, K.M.F., HARRISON, A.D. & MACNAE, W., 1952. The ecology of South African estuaries, Part 2: The Klein River estuary, Hermanus. Transactions of the royal society of South Africa, 33: 283-331.
- SEGERSTRÅLE, S.G., 1959. Brackish water classification, a historical survey. Archivio di oceanografia e limnologia, 11, Suppl.: 7-33.
- STIEGFRIED, W.R., 1978. Estuaries, ecology and conservation in South Africa. South African journal of science, 74(11): 406-407.
- SIEGFRIED, W.R., 1981(a). Classification of estuaries: Unpublished proceedings of the First meeting of the ad hoc working group on classification of estuaries, held 8 June 1981 at the Directorate of Forestry, Cape Town. (Doc.4) DWAPEC: 1-46.
- SIEGFRIED, W.R., 1981(b). The estuarine avifauna of Southern Africa. In: DAY, J.H. ed. Estuarine ecology: with particular reference to Southern Africa. Cape Town, A.A. Balkema: 223-250.
- SMITH, J.L.B., 1935. The fishes of the family Mugilidae in South Africa. Annals of the South African museum, 30(5): 587-644.
- SMITH, J.L.B., 1938. The South African fishes of the families Sparidae and Denticidae. Transactions of the royal society of South Africa, 26(3): 225-305.
- SMITH, J.L.B., 1959. Gobioid fishes of the families Gobiidae, Periophthalmidae, Trypauchenidae, Taenioididae and Kraemeriidae of the Western Indian Ocean. Ichthyological bulletin, (13): 185-225.
- SMITH, J.L.B., 1965. The Sea Fishes of Southern Africa. South Africa, Central News Agency: 1-580.
- SMITH, M.M. & JACKSON, P.B.N., 1975. Common and scientific names of the fishes of Southern Africa, I: Marine fishes; II: Freshwater fishes. Special publication. J.L.B. Smith institute of ichthyology, (14): 1-213.
- SPADA, N. ed., 1959. Symposium on the classification of brackish waters. Venice, 8-14 Apr 1958. Archivio di oceanografia e limnologia, 11 Suppl.: 1-248.
- STAPLES, D.J. & VANCE, D.J., 1979. Effects of changes in catchability on sampling of juvenile and adolescent banana prawns, Penaeus merguensis de Man. Australian journal of marine and freshwater research, 30(4): 511-519.
- TAYLOR, J.L. & SALOMAN, C.H., 1968. Some effects of hydraulic dredging and coastal development in Boca Ciega Bay, Florida. Fishery bulletin, 67(2): 213-241.
- TRUTER, R. & GILMORE, J.A., 1970. The use of coastal lagoons for water supply. Convention on water for the future, Water year 1970, Pretoria, 16-20 Nov 1970: 1-4.

- TYSON, P.D. & DYER, T.G.J., 1978. The predicted above-normal rainfall of the seventies and the likelihood of droughts in the eighties in South Africa. South African journal of science, 74: 372-377.
- VÄLIKANGAS, I., 1926. Planktologische untersuchungen im hafengebiet von Helsingfors, 1: Über das plankton, insbesondere das netz-zooplankton, des sommerhalbjahres. Acta zoologica fennica, 1: 1-298.
- VAN DER ELST, R.P., 1979. Changes in populations of estuarine associated sport fish in Natal. Fourth National Oceanographic Symposium, Cape Town, 10-13 Jul 1979: 1-9. Unpublished paper.
- VAN DER ELST, R.P., BLABER, S.J.M., WALLACE, J.H. & WHITFIELD, A.K., 1976. The fish fauna of lake St Lucia under different salinity regimes. The St Lucia Scientific Advisory Council Workshop meeting, Charters Creek, 15-17 Feb 1976: 1-10.
- VAN DER ELST, R.P. & WALLACE, J.H., 1976. Identification of the juvenile mullet of the east coast of South Africa. Journal of fish biology, 9: 371-374.
- VAN GROENEWOUD, H., 1965. Ordination and classification of Swiss and Canadian coniferous forests by various biometric and other methods. Bericht Eidgenössische Technische Hochschule, Geobotanisches institut, Stiftung Rübél, Zürich, 36: 28-102.
- WALFORD, L.A., 1966. The estuary as a habitat for fishery organisms. In: SMITH, R.F., SWARTZ, A.H. & MASSMANN eds. A symposium on estuarine fisheries. Special publications. American fisheries society, (3):15.
- WALLACE, J.H., 1975(a). The estuarine fishes of the east coast of South Africa, 1: Species composition and length distribution in the estuarine and marine environments; 2: Seasonal abundance and migrations. Investigational report, Oceanographic research institute, (40): 1-72.
- WALLACE, J.H., 1975(b). The estuarine fishes of the east coast of South Africa, 3: Reproduction. Investigational report, Oceanographic research institute, (41): 1-51.
- WALLACE, J.H., 1975(c). The estuarine fishes of the east coast of South Africa, 4: Occurrence of juveniles in estuaries; 5: Ecology, estuarine dependence and status. Investigational report, Oceanographic research institute, (42): 1-63.
- WALLACE, J.H., BECKLEY, L.E., BENNETT, B., BLABER, S.J.M., KOK, H.M. & WHITFIELD, A.K., 1983. How dependent on estuaries are South African fishes? South African journal of science, 79: 158. Abstract.

- WHITFIELD, A.K., 1976. An investigation of the family Mugilidae in lake St Lucia, Zululand, with special reference to predation and population densities. The St Lucia Scientific Advisory Council Workshop meeting, Charters Creek, 15-17 Feb 1976: 1-12.
- WHITFIELD, A.K., 1980(a). A quantitative study of the trophic relationships within the fish community of the Mhlanga Estuary. Estuarine and coastal marine science, 10: 417-435.
- WHITFIELD, A.K., 1980(b). Factors influencing the recruitment of juvenile fishes into the Mhlanga estuary. South African journal of zoology, 15(3): 166-169.
- WHITFIELD, A.K. & BLABER, S.J.M., 1976. The effects of temperature and salinity on Tilapia rendalli Boulenger 1896. Journal of fish biology, 9: 99-104.
- WHITFIELD, A.K. & BLABER, S.J.M., 1979. The distribution of the freshwater cichlid Sarotherodon mossambicus in estuarine systems. Environmental biology of fishes, 4(1): 77-81.
- WHITFIELD, A.K., BLABER, S.J.M. & CYRUS, D.P., 1981. Salinity ranges of some southern African fish species occurring in estuaries. South African journal of zoology, 16(3): 151-155.
- WHITTAKER, R.H., 1962. Classification of natural communities. Botanical review, 28: 1-239.
- WHITTAKER, R.H., 1967. Gradient analysis of vegetation. Biological reviews, 42: 207-264.
- WILEY, M.L. ed., 1978. Estuarine interactions. New York, Academic Press: 1-603.
- WILLIAMS, W.T., 1971. Principles of clustering. Annual review of ecology and systematics, 2: 303-326.
- WILSON, M.V., 1981. A statistical test of the accuracy and consistency of ordinations. Ecology, 62(1): 8-12.
- WOOLDRIDGE, T., 1976. The zooplankton of Msikaba estuary. Zoologica africana, 11: 23-41.

Personal communications

A list of the names and addresses of the people consulted

BALLARD, J. - ORI, POB 10712, Marine Parade 4056 Durban

BICKERTON, I.- NRIO, POB 320, Stellenbosch 7600

BOWMAKER, Prof. A.P.- ORI, POB 10712, Marine Parade 4056 Durban

CYRUS, D.P.- University of Natal, POB 375, Pietermaritzburg 3200

DAY, Prof. J.H.- University of Cape Town, Rondebosch 7700

GARDNER, B. - NIWR : CSIR, POB 17001, Congella 4013

GOODMAN, P.- NPB, POB 662, Pietermaritzburg 3200

LITTLE, A.M.- NTRPC, P/B 9038, Pietermaritzburg 3200

LORD, Dr D.- CSP : CSIR, POB 395, Pretoria 0001

MARTIN, T.- University of Natal, POB 375, Pietermaritzburg 3200

PISTORIUS, R.- Director of Local Govt., P/B 9038, Pietermaritzburg 3200

SMITH, Prof. M.M.- JLB Smith Institute, P/B 1015, Grahamstown 6140

SWART, Dr H. - NRIO, POB 320, Stellenbosch 7600

VAN DER ELST, R. - ORI, POB 10712, Marine Parade 4056, Durban

VAN DUYN, M. - 'Koelwaters', POB 71, Port Edward 4295

WALLACE, Dr J. - Port Elizabeth Museum, POB 13147, Humewood 6013.

FRESH



□ Tougati

□ Mgeni

□ Mfomazi

● Mlloxi

● Mbokodweni

● Mdeligane

□ Marumbe

● Mzimayi

□ Mwalume

● Masizintoti

● Little Manzintoti

● Mtrumbane

● Mtrumbane

□ Mtsavvana

● Mhlanga

● Mbang

● Mvutshini

● Boboyi

● iNtabambili

□ Mzimikula

● Mhlabatsheane

● Mhlabatsheane

● Kandi

● Ntso

● Kongweni

□ Lovu

● Msimbezi

● Msimbezi

● Ngane

● Mzantsi

● Mzantsi

□ Mhledi

● uMgababe

● Mntentweni

● Kwa Makoti

● Mzantsi

● Mzantsi

● Sipingo

● Mpenjati

● Mntentweni

● Mntentweni

● Mntentweni

● Mpenjati

● Mntentweni

● Mntentweni

● Mntentweni

● Mntentweni

● Mntentweni

● Mntentweni

● Mntentweni

● Mntentweni

● Mntentweni

□ Saodlundlu

● Mntentweni

● Mntentweni

● Mntentweni

● Mntentweni

● Mntentweni

● Mntentweni

● Mntentweni

● Mntentweni

● Mntentweni

● Ziakwesi



SALINE

OPEN

CLOSED

Axis 2

Axis 1



FIG. 10

• *Clarias gariepinus*

• *Barbus viviparus*

• *Aplocheilichthys myxosus*

• *Tilapia rendalli*

• *Pseudocrenilabrus philander*

FRESHWATER

• *Megalops cyprinoides*

• *Barbus natalensis*

• *Myxus capensis*

• *Redigobius bikolanus*

• *Gerres actinaces*

• *Mugil cephalus*

• *Tetraodon lineatus*

• *Liza macrolepis*

• *Kribia laeniurus*

• *Liza dammeri*

• *Oligolepis acutipennis*

• *Monodactylus falciformis*

• *Volamugil buchanani*

• *Liza richardsoni*

• *Gerres rappa*

EURYHALINE

• *Gilchristella aestuarius*

• *Oreochromis mossambicus*

• *Glossogobius giuris*

• *Solea bleekeri*

• *Redigobius deuvali*

• *Crotila mossambica*

• *Ambassis productus*

• *Micropterus dolomieu*

• *Scomberoides commersonianus*

• *Penophrichthys sobrius*

• *Callionymus marleyi*

• *Fistularia petimba*

• *Pomadasys maculatus*

• *Scomberoides lala*

• *Favonogobius melanobranchius*

• *Asteromus oligospiros*

• *Tetraodon lineatus*

• *Pomadasys multimaculatum*

• *Stolepobus commersonii*

• *Plectrohynchus niger*

• *Lobotes surinamensis*

• *Pomadasys hololepidotus*

• *Acrossopterygus ocellatus*

• *Favonogobius reschei*

• *Elops machnata*

• *Platycephalus indicus*

• *Sillago sihama*

• *Secutor insularis*

• *Syngnathus djirong*

• *Asteromus striatus*

• *Epiplatys andersoni*

• *Bufo butsi*

• *Glossogobius biocellatus*

• *Arothron immaculatus*

• *Thyrostoeida macrura*

• *Gerres punctatus*

• *Lactoria cornuta*

• *Arothron hispidus*

STENOHALINE

• *Paraphagus himalaia*

• *Tachirostus russelli*

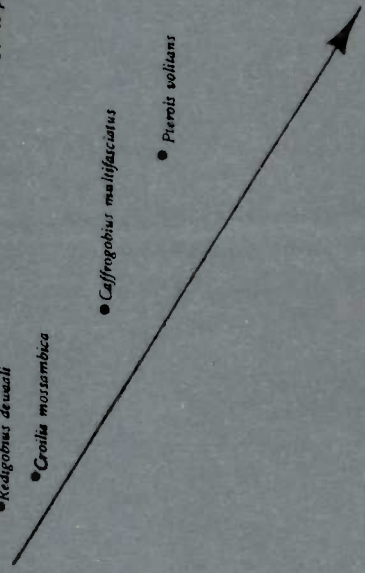
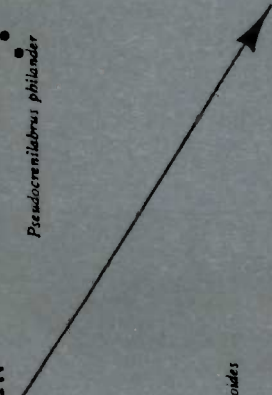

AXIS 2

AXIS 1

• *Macrobrachium petersii*
 • *Macrobrachium lepidactylus*

FRESHWATER

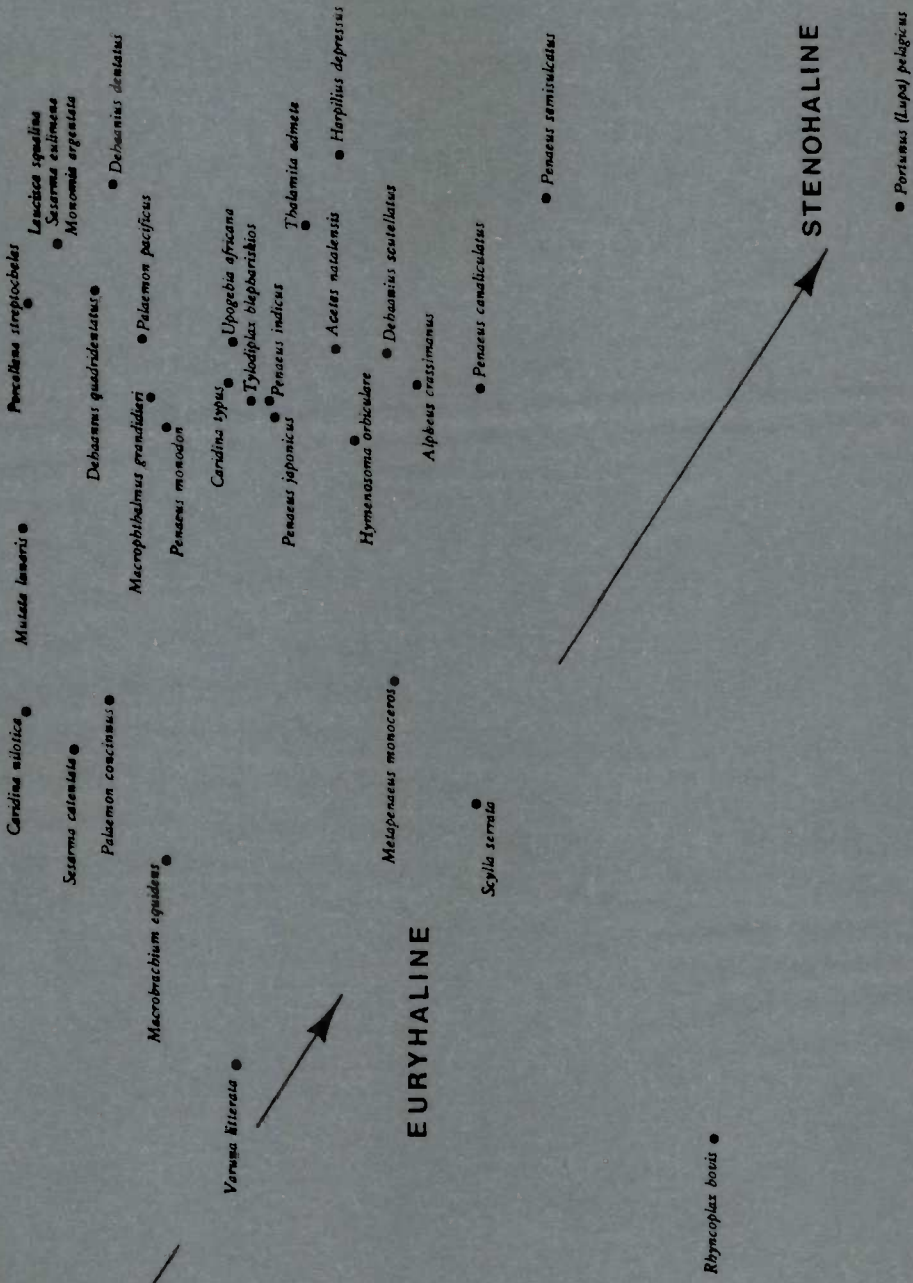

EURYHALINE

STENOHALINE

• *Portunus (Lupus) pelagicus*
 • *Parapenaeopsis acellivirostris*
 • *Calappa hepatica*
 • *Pinnacus sp. ? (sensibilis)*

Axis 1

Axis 2

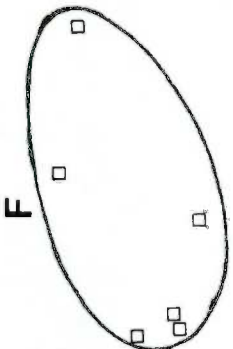
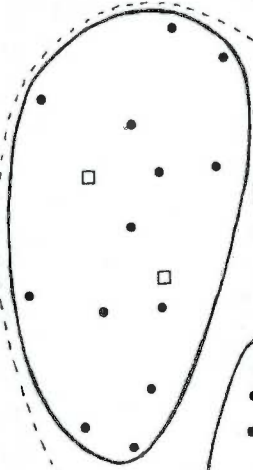
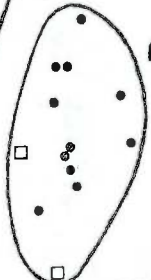
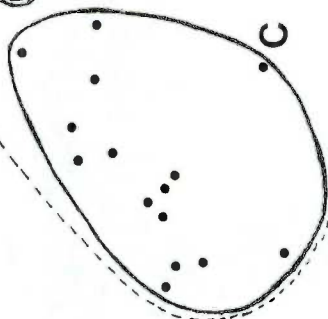
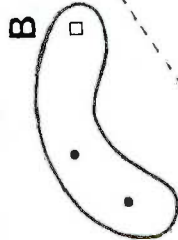

Axis 2 ←

Axis 1 →

FIG. 14